



TBIMOTION®

Linear Motion System

- Linear Guide
- Ball Spline
- Ball Screw
- Rotary Series
- Single Axis Actuator
- Accessory



Exploring the infinite possibility of technology for life

TBI MOTION TECHNOLOGY CO., LTD.

About TBI MOTION

TBI MOTION TECHNOLOGY CO., LTD., as a specialized manufacturer in Linear Motion Industry in Taiwan, possesses critical core technology and concentrating on product development and innovation. Our products are under patent design with ISO 9001:2008 and credited with Taiwan Excellence Awards. We look forward to working with you as your best partner providing you with solution and professional product to create a better future.

Philosophy / TBI MOTION creates advantageous circumstances through collaboration and keeps being innovative to satisfy the needs of our customers.

Mission / Best Partners of Production & Solution in Linear Motion.

Vision / TBI inside, as the prospect of helping our clients explore the infinite possibility of technology for life by utilizing our products inside of them.



TBI Taiwan Headquarter

History

TBI

1986

- Founded in Tucheng, Taipei, we established the first factory that specialized in Rolled Ball Screw in Taiwan.
- We built our first R&D center focusing on the development of Ground Ball Screw.

1988

- The Fengyuan factory in Taichung started to operate and focused on manufacturing Ground Ball Screws.

COMTOP

2002

- The **COMTOP** system was founded as a professional marketing division.

TBI TBIMOTION

2010

- By integrating **TBI** with **COMTOP** Marketing System, **TBI MOTION** officially became the brand that led the trend in the market.
- Established Yingge factory

2014

- **TBI MOTION** officially Initial Public Offering (IPO).

2016

- The Shulin Headquarter officially operated.

2018

- **TBI MOTION** is officially a Initial Public Offering (IPO) Company, Stock No. 4540

Quality Policy



HIGH PERFORMANCE



HIGH RIGIDITY



HIGH MECHANICAL EFFICIENCY



HIGH DURABILITY



EASY TO MAINTAIN



Laser Conduction Test



Outline Measurement



Projection Measurement



Rigidity Test



Metallographic Test



Torque Test



Accuracy Test

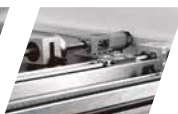

Durability Test

Applicable Fields

Professional motion compartment manufacturer

TBI motion possesses complete product line with MIT(made in Taiwan) quality.

We produce Ball Screw, Linear Guide, Rotary Series, Single Axis Actuator, Linear Bearing, Coupling, Support Unit of Ball Screw, etc. All of them perform remarkably in each application field. With the professional technical support and industry analysis, we fulfill our clients' demand and attain differentiation.

Our products apply to various fields as below :



Sales Location

Through our distributors worldwide, we are connected with the world, by constantly surpassing ourselves to overcome every challenge in the future.

Taiwan

China

Korea

Thailand

Vietnam

Singapore

Malaysia

Japan

Indonesia

Iran

United States

Brazil

Germany

Italy

Netherlands

France

Hungary

Romania

Slovakia

Ukraine

Turkey

Russia

Finland

Poland

Austria

Portugal

United Kingdom

Australia



Product

Linear Guide

Standard TR-V



Standard TR-F



Self-lubricated TR

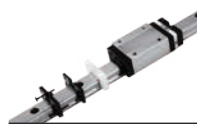

Miniature TM-N/W
(Standard/Wide version)



Ball Spline

SLF



SLT



SOF



SOT



Ball Screw

SFNH



SFH



SFNU



SFNI



SCNH



SFY
(High Dm-N value)



SFV



XSV



SFK



SCI



BSH



SFM/DFM



Integrated Double Nut

OFU



OFI



OFV



ICON Description



Miniature



Specially for
Milling Machine



Specially for
Actuator



Capable to use
in high speed
and heavy loading



DIN Certified

Rotary Series

RFBY



RLBF



RBBY



RBLY



RFSY



RLSF



RSSY



RSLY



Single Axis Actuator

Standardize KP



Low Setting Support Unit KP



Aluminum Dust Proof Cover KP



Accessory

Support Unit for Ball Screw



Linear Bearing



Coupling



1-1 Features of TBI MOTION Linear Guide	A02
1-2 The Procedure of Selecting Linear Guide	A05
1-3 Basic Load Rating and Service Life of Linear Guide	A06
1-4 Friction	A13
1-5 Working Load	A14
1-6 Safety Factor and Load	A20
1-7 Calculation of Average Working Load	A28
1-8 Calculation Example	A32
1-9 Accuracy	A40
1-10 Predicting the Rigidity	A42
1-11 Installation of Linear Guide	A44
1-12 Lubrication	A56
1-13 Precautions of Linear Guide	A57
2-1 The Types of TBI MOTION Linear Guide	A58
2-2 TRH / TRS / TRC International Standard Linear Guide	A59
2-2-3 TR-Series	A60
2-2-4 Nominal Model Code for Non-interchangeable TR Type	A61
2-2-5 Nominal Model Code for Interchangeable TR Type	A62
TRH-V Series Specifications	A64
TRH-F Series Specifications	A66
TRS-V Series Specifications	A68
TRS-F /TRC-V Series Specifications	A70
2-2-6 The Standard Length and Maxima Length of Linear Rail	A72
2-2-7 Mounting Type of Linear Rail	A72
2-2-8 Accuracy Standard	A74
2-2-9 Determining the Magnitude of a Preload	A76
2-2-10 Mounting Location of Grease Nipples	A77
2-2-11 Grease Nipples	A78
2-2-12 J-Flow System	A80
2-2-13 Strong Dust-proof/Self-Lubricating Linear Guide Series Accessory	A81
2-2-14 Dust-proof/Accessory	A86
2-2-15 Friction	A91
2-2-16 Mounting-Surface Dimensional Tolerance	A92
2-3 TM Miniature Linear Guide	A93
2-3-1 The Characteristics of TM Series	A93
2-3-2 The Structure of TM-series	A94
2-3-3 Accuracy	A94
2-3-4 Preload	A95
2-3-5 Types of Lubrication	A96
2-3-6 Order Information	A96
2-3-7 Nominal Model Code of TM Type	A98
TM-N/TM-W Series Specifications	A99

B

1-1 Structure and Benefits of TBI MOTION Ball Spline	B02
1-2 The Procedure to Select Ball Spline	B05
2-1 The Strength of Spline Shaft	B06
2-2 Service Life Expectancy	B12
2-3 Calculating the Service Life	B16
2-4 Determining the Preload	B20
2-5 Accuracy	B22
2-6 Lubrication	B24
2-7 Material and Surface Treatment	B24
2-8 Precautions of Ball Spline	B25
2-9 Mounting	B26
3-1 Nominal Model Code of Ball Spline SL Series	B28
SLF Series Specifications	B32
SLT Series Specifications	B34
3-2 Nominal Model Code of Ball Spline SO Series	B36
SOF Series Specifications	B40
SOT Series Specifications	B42

Ball Spline



1-1 Features of TBI MOTION Ball Screw	C02
1-2 Ball Screw Selection Procedure	C04
1-3 Accuracy	C05
1-4 Screw Shaft Design	C11
1-5 Driving Torque	C17
1-6 Nut Design	C19
1-7 Rigidity	C21
1-8 Positioning Accuracy	C24
1-9 Service Life Design	C26
1-10 Cautions About Use of Ball Screws	C32
2-1 Nominal Model Code of Ball Screw	C36
2-2 Precision Ground Ball Screw Series	C39
2-2-1 TBI MOTION Nut of Precision Ground Ball Screw Type	C39
SFNH/SFH Series Specifications	C44
SCNH Series Specifications	C45
SFNU/SFU Series Specifications	C46
OFU/DFU Series Specifications	C47
SFNI/SFI/SFM Series Specifications	C48
OFI/DFI/DFM Series Specifications	C49
SFV Series Specifications	C50
OFV /DFV Series Specifications	C51
SFY Series Specifications	C52
DFS Series Specifications	C53
SCNI/SCI Series Specifications	C54
SFK Series Specifications	C55
BSH Series Specifications	C56
XSV Series Specifications	C57
2-3 Rolled Ball Screw	C62
2-3-1 Rolled Screws	C62
2-3-2 The Features of TBI MOTION Rolled Ball Screw	C62
2-3-3 Nominal Model Code of Rolled Ball Screws	C62
2-3-4 Preload of Rolled Ball Screw	C65
2-4 Rolled Ball Screw Series	C66
2-4-1 TBI MOTION Nut of Rolled Ball Screw Type	C66
SFNH/SFH Series Specifications	C69
SCNH Series Specifications	C70
SFNU/SFU Series Specifications	C71
SFNI/SFI/SFM Series Specifications	C72
SFV Series Specifications	C73
SFY Series Specifications	C74
XSY Series Specifications	C75
SCNI/SCI Series Specifications	C76
SFK Series Specifications	C77
BSH Series Specifications	C78

D

Rotary Series

1-1 Features of TBI MOTION Precision Rotary Ball Screw/Spline	D02
1-2 Accuracy	D05
1-3 Example of Assembly - RFBY	D10
1-4 Example of Assembly - RBBY	D11
1-5 Nominal Model Code of Rotary Series	D12
RFBY Series Specifications	D14
RLBF Series Specifications	D15
RBBY Series Specifications	D16
RBLY Series Specifications	D18
RFSY Series Specifications	D20
RLSF Series Specifications	D21
RSSY Series Specifications	D22
RSLY Series Specifications	D24

E

Single Axis Actuator

1-1 Structure and Features of TBI MOTION Actuator	E02
1-2 Features of the Single Axis Actuator	E03
1-3 Purchase of Peripherals	E04
1-4 Accuracy Design	E08
1-5 Maximum Speed	E09
1-6 Calculation of Service Life	E10
1-7 Lubrication	E13
1-8 KP Product Series	E14
KP26 (Standard Type)	E14
KP26(Standard Type with Protective Cap)	E15
KP26(Low-Assembly)	E16
KP33(Standard Type)	E17
KP33(Standard Type with Protective Cap)	E18
KP33(Low-Assembly)	E19
KP33(Light-Load Type)	E20
KP33(Light-Load Type with Protective Cap)	E21
KP33(Light-Load Type, Low-Assembly)	E22
KP46(Standard Type)	E23
KP46(Standard Type with Protective Cap)	E24
KP46(Low-Assembly)	E25
KP46(Light-Load Type)	E26
KP46(Light-Load Type with Protective Cap)	E27
KP46(Light-Load Type, Low-Assembly)	E28
1-9 The Adapting Flange of the Motor Base and the Motor	E29

Index



1-1 Features of TBI MOTION Linear Ball Bearing	F02
LM Series Specifications (Standard)	F02
LM-L Series Specifications (Lengthen)	F03
LF Series Specifications (Flange Type)	F04
LF-L Series Specifications (Flange Type with Lengthen Nut)	F05
LU/LP Series Specifications (Aluminum Housing Type)	F06
SF/WV Series Specifications (Shaft)	F07
SS Series Specifications (Shaft Support)	F08



1-1 Features of TBI MOTION Support Unit of Ball Screw	G02
1-2 Assembling Steps of TBI MOTION Linear Ball Bearing	G04
1-3 Checking Geometric Accuracy	G05
1-4 Connect Ball Screw Motor	G05
BK Series (Fixed End)	G06
BK Series (Fixed End)	G08
BF Series (Floated End)	G10
EK Series (Fixed End)	G12
EK Series (Fixed End)	G14
EF Series (Floated End)	G16
FK Series (Fixed End)	G18
FK Series (Fixed End)	G20
FF Series (Floated End)	G22



1-1 Features of TBI MOTION Coupling	H02
SRJ Specifications	H02
Function	H03

Linear Guide



1-1 Features of tbmotion Linear Guide.....	A02
1-2 The Procedure of Select Linear Guide.....	A05
1-3 Basic Load Rating and Service Life of Linear Guide.....	A06
1-4 Friction.....	A13
1-5 Working Load.....	A14
1-6 Safety Factor and Load.....	A20
1-7 Calculation of Average Working Load.....	A28
1-8 Calculation Example.....	A32
1-9 Accuracy.....	A40
1-10 Predicting the Rigidity.....	A42
1-11 Installation of Linear Guide.....	A44
1-11-1 Datum Representation.....	A44
1-11-2 Recognizing of Master Rail.....	A45
1-11-3 For Butt-joint Rail.....	A46
1-11-4 Mounting Methods.....	A47
1-11-5 Common Fastening Method of Linear Guide.....	A48
1-11-6 Mounting the Linear Guide.....	A49
1-12 Lubrication.....	A56
1-13 Precautions of Linear Guide.....	A57
2-1 The Types of TBI MOTION Linear Guide.....	A58
2-2 TRH / TRS / TRC International Standard Linear Guide.....	A59
2-2-3 TR-Series.....	A60
2-2-4 Nominal Model Code for Non-interchangeable TR Type.....	A61
2-2-5 Nominal Model Code for Interchangeable TR Type.....	A62
2-2-6 The Standard Length and Maxima Length of Linear Rail.....	A72
2-2-7 Mounting Type of Linear Rail.....	A72
2-2-8 Accuracy Standard.....	A74
2-2-9 Determining the Magnitude of a Preload.....	A76
2-2-10 Mounting Location of Grease Nipples.....	A77
2-2-11 Grease Nipples.....	A78
2-2-12 J-Flow System.....	A80
2-2-13 Strong Dust-proof/Self-Lubricating Linear Guide Series Accessory.....	A81
2-2-14 Dust-proof/Accessory.....	A86
2-2-15 Friction.....	A91
2-2-16 Mounting-Surface Dimensional Tolerance.....	A92
2-3 TM Miniature Linear Guide.....	A93
2-3-1 The Characteristics of TM Series.....	A93
2-3-2 The Structure of TM-series.....	A94
2-3-3 Accuracy.....	A94
2-3-4 Preload.....	A95
2-3-5 Types of Lubrication.....	A96
2-3-6 Order Information.....	A96
2-3-7 Nominal Model Code of TM Type.....	A98

ABOUT LINEAR GUIDE

1-1 Features of *TBI MOTION* Linear Guide

■ 1-1-1 High Accuracy

Linear Guide has little friction, only a small driving force is needed to move the load. Low friction helps the temperature rising effect to stay low. Thus, the friction is decreased and the accuracy can be maintained for a long period than tradition slide system.

■ 1-1-2 High Rigidity

The design of Linear Guide features an equal load rating in all directions that provide sufficient rigidity load in all directions, self-aligning capability to absorb installation-error. Moreover, a sufficient preload can be achieved to increase rigidity and makes it suitable for any kind of installation.

■ 1-1-3 Easy for Maintenance

Compared with high-skill required scrapping process of traditional slide system, the Linear Guide can offer high precision even if the mounting surface is machined by milling or grinding. Moreover, the interchangeability of Linear Guide gives a convenience for installation and future maintenance.

■ 1-1-4 High Speed

Linear Guide block, rail and ball apply by contact point of rolling system. Due to the characteristic of low friction, the required driving force is much lower than that in other systems, thus the power consumption is low. Moreover the temperature rising effect is lower even under high speed operation.

■ 1-1-5 High Mechanical Efficiency without Clearance

Table 1.1.1

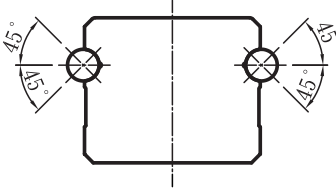
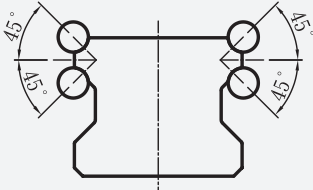
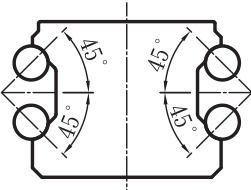
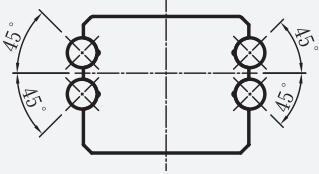
Drawing	Characteristics, Performance
	<ul style="list-style-type: none"> ● Two trains of balls. ● In a Gothic-arch groove, each ball contacts the raceway at four points 45°- 45°. ● It has constant contact point between ball and arc groove. ● Rigidity has high stability. ● Two-row design is able to perform an equal load rating in four directions.
	<ul style="list-style-type: none"> ● Four trains of balls. ● The circular-arc groove has two contact points at 45°- 45°(DF)-Four-Row Design features an equal load rating in all four directions with high rigidity. ● Four-row design is able to perform an equal load rating in four directions. ● Self-Aligning to absorb installation-error.
	<ul style="list-style-type: none"> ● Four trains of balls. ● The circular-arc groove has two contact points at 45°- 45° (DB). ● Four-Row Design features an equal load rating in all four directions with high rigidity. ● Low friction promotes smooth operating condition.
	<ul style="list-style-type: none"> ● Four trains of balls. ● In the Gothic-arch groove, each ball contacts the raceway at two points 45°- 45°, Light preload, two contact points, Heavy preload, four contact points. ● Compared with traditional DB type, it has higher rigidity.

ABOUT LINEAR GUIDE

1-1 Features of *TBI MOTION* Linear Guide

The Contract table of four-row design with equal load rating and two-row Gothic design.

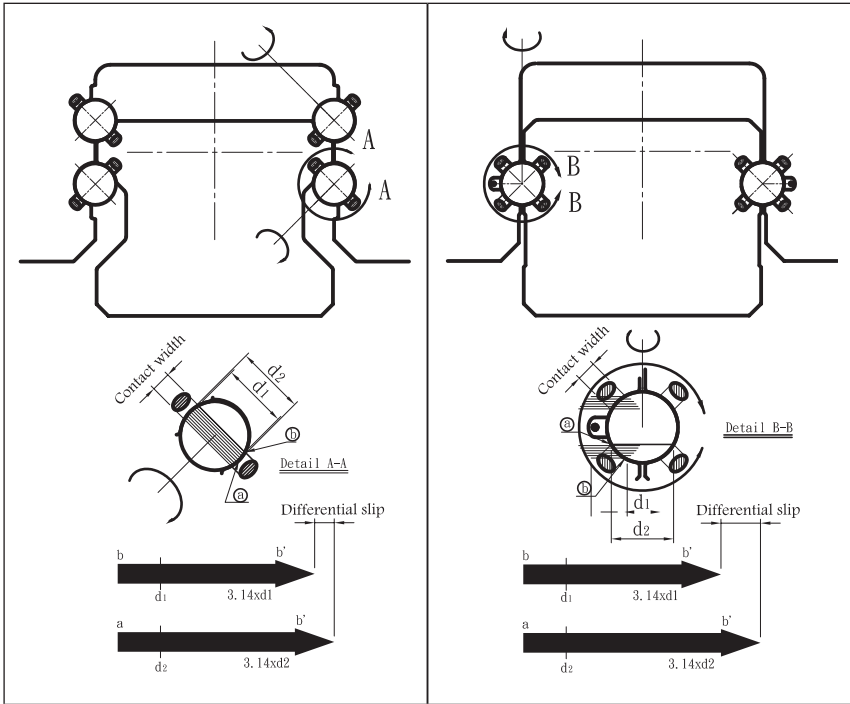

Fig 1.1.1 Four-Row Equal Load Rating Design

Fig 1.1.2 Four-Row Equal Load Rating Design

As shown in the diagram, the difference between inner surface circumference(πd_1)and outer surface circumference(πd_2)which is the contact point of ball, it is the slip that will occur while the ball rolling, this is called differential slip.. if the differential slip is larger, the ball will rotate while rolling, increasing the friction coefficient and friction resistance. Under the condition with preload and loading, due to the two point of contact the difference between d_1 and d_2 is little, the differential slip is little as well, the smoothness of rolling can be achieved and thus increase efficiency.

1-2 The Procedure of Select Linear Guide

1-2-1 Flowchart

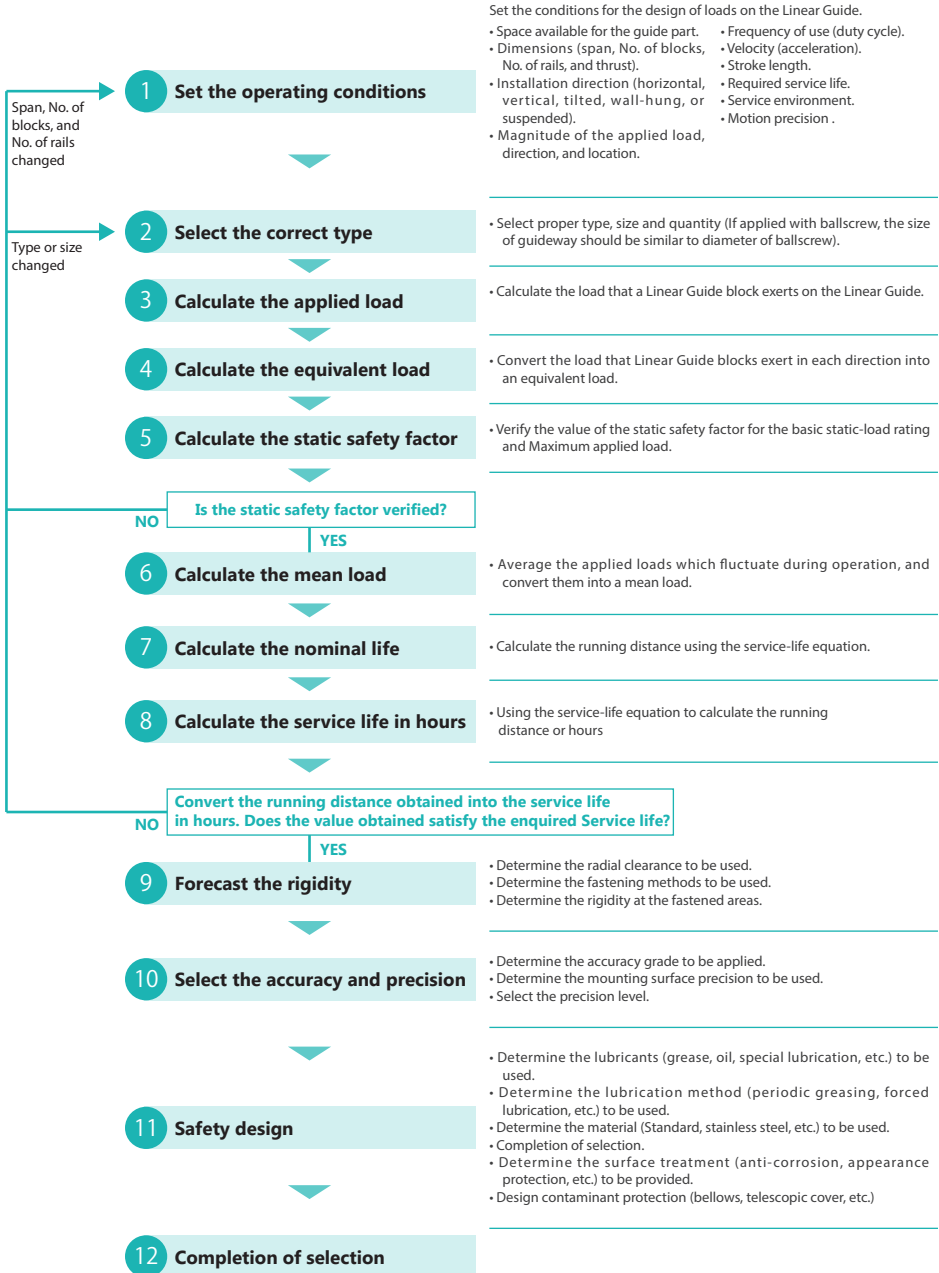

ABOUT LINEAR GUIDE

1-3 Basic Load Rating and Service Life of Linear Guide

When determining a model that would suit your service conditions for a linear motion system, the load carrying capacity and service life of the model must be considered. To consider the load carrying capacity you should know the static safety factor of the model calculation based on the basic static load rating. Service life can be assessed by calculating the nominal life based on the basic dynamic load rating and checking to see if the obtained value meet your requirements.

The service life of a linear motion system refers to the total running distance that the linear motion system travels until flaking (the disintegration of a metal surface in scale-like pieces) occurs there to as a result of the rolling fatigue of the material caused by repeated stress on raceways and rolling elements.

Basic Load Rating : There are two basic load ratings for linear motion systems : basic static load rating (C_0), which sets the static permissible limits, and basic dynamic load rating (C).

■ 1-3-1 Basic Static Load Rating (C_0)

If a linear motion system, whether at rest or in motion, receives an excessive load or a large impact, a localized permanent set develops between the raceway and rolling elements. If the magnitude of the permanent set exceeds a certain limit, it hinders the smoothness of the motion system.

The basic static load rating refers to a static load in a given direction with given magnitude such that the sum of the permanent set of the rolling elements and that of the raceway at the contact area under the most stress is 0.0001 times greater than the rolling element diameter.

In linear motion systems, the basic static load rating is defined as the radial load. Thus the basic static load rating provides a limit on the static permissible load.

■ 1-3-2 Basic Permissible Moment (M_x , M_y , M_z)

When a Linear Guide gets a force that makes the balls distorted to 1/10,000 of their diameter, we call the force as basic static permissible moment. Values of M_x , M_y , M_z are shown on Fig 1.3.1, which suggest 3 axis of moment on a Linear Guide slide.

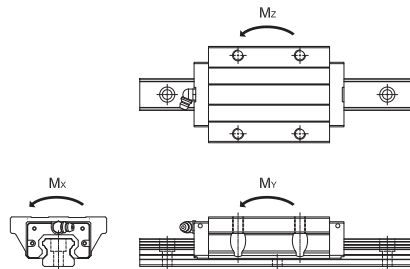

Fig 1.3.1

■ 1-3-3 Static Safety Factor f_s

$$f_s = \frac{C_o}{P} \text{ or } \frac{M_o}{M}$$

f_s : static safety factor
 C_o : basic static load rating (N)
 M_o : static permissible moment (N-mm)
 P : calculated load (N)
 M : calculated moment (N-mm)

A linear motion system may possibly receive an unpredictable external force due to vibration and impact while it is at rest or is moving or due to inertia resulting from start and stop. It is therefore necessary to consider the static safety factor against operating loads like these. The static safety factor (f_s) indicates the ratio of a linear motion system load carrying capacity 【basic static load rating C_o 】 to the load exerted there on.

To calculate the applied load on Linear Guide, mean load and static safety factor must be obtained in advance. In the working environment with high intensity while start and stop, cantilever or cutting, a unexpected heavy load may occurs, therefore the maximum load must be acquired. Datum values of static safety factor are shown below;

Table 1.3.1 Static Safety Factor f_s

Machine Used	Loading Conditions	f_s lower limit
Ordinary Industrial Machine	Receives no vibration or impact	1.0-1.3
	Receives vibration and impact	2.0-3.0
Machine Tool	Receives no vibration or impact	1.0-1.5
	Receives vibration and impact	2.5-7.0

For large radial loads	$\frac{f_h \cdot f_t \cdot f_c \cdot C_o}{P_R} \geq f_s$
For large reverse-radial loads	$\frac{f_h \cdot f_t \cdot f_c \cdot C_{oL}}{P_L} \geq f_s$
For large lateral loads	$\frac{f_h \cdot f_t \cdot f_c \cdot C_{oT}}{P_T} \geq f_s$

f_s : Static safety factor
 C_o : Basic static-load rating (radial) (N)
 C_{oL} : Basic static-load rating (reverse-radial) (N)
 C_{oT} : Basic static-load rating (lateral) (N)
 P_R : Calculated load (radial) (N)
 P_L : Calculated load (reverse-radial) (N)
 P_T : Calculated load (lateral) (N)
 f_h : Hardness factor (Fig1.3.2)
 f_t : Temperature factor (Fig1.3.3)
 f_c : Contact factor (Table1.3.2)

ABOUT LINEAR GUIDE

1-3 Basic Load Rating and Service Life of Linear Guide

■ 1-3-4 Service Life (L)

Even when identical linear guideways in a group are manufactured in the same way or applied under the same condition, the service life may be varied. Thus, the service life is used as an indicator for determining the service life of a linear guideway system. The nominal life (L) is defined as the total running distance that 90% of identical linear guideways in a group, when they are applied under the same conditions, can work without developing flaking.

■ 1-3-5 Basic Dynamic Load Rating (C)

Basic dynamic load rating (C) can be used to calculate the service life when linear guideway system response to a load. The basic dynamic load rating (C) is defined as a load in a given direction and with a given magnitude that when a group of linear guideways operate under the same conditions. As the rolling element is a ball, the nominal life of the linear guideway is 50 km. Moreover, as the rolling element is a roller, the nominal life is 100 km.

■ 1-3-6 Calculation of Nominal Life

The service lives of linear motion system more or less various from system to system even if they are manufactured to the same specifications and remain in service under the same operating conditions. Hence, a guideline for determining the service life of a linear motion system is based on nominal life, which is defined as follows. The nominal life refers to the total running distance that 90% of identical linear motion systems in a group, when interlocked with one another under the same conditions, can achieve without developing flaking. The nominal life (L) of a linear motion system can be obtained from the basic dynamic load rating (C) and load imposed (P_c) using the following equations.

For a linear motion system with balls

$$L = \left(\frac{f_h \cdot f_t \cdot f_c}{f_w} \cdot \frac{C}{P_c} \right)^3 \cdot 50$$

For a linear motion system with rollers

$$L = \left(\frac{f_h \cdot f_t \cdot f_c}{f_w} \cdot \frac{C}{P_c} \right)^{\frac{10}{3}} \cdot 100$$

Service-Life Equation

The service life of the Linear Guide can be obtained using the following equation :

$$L = \left(\frac{f_h \cdot f_t \cdot f_c}{f_w} \cdot \frac{C}{P_c} \right)^3 \cdot 50 \text{ km}$$

(total distance that can be traveled by at least 90% of a group of Linear Guide operated under the same conditions)

- C : basic dynamic-load rating (N)
- P_c : calculated load (N)
- f_h : hardness factor (Fig 1.3.2)
- f_t : temperature factor (Fig 1.3.3)
- f_c : contact factor (Table 1.3.2)
- f_w : load factor(N) (Table 1.3.3)

$$L_h = \frac{L \cdot 10^6}{2 \cdot l_s \cdot N_1 \cdot 60}$$

- L_h : service life in hours (h)
- l_s : stroke length (mm)
- N₁ : No. of reciprocating cycles per min (min⁻¹)

(Once nominal life (L) is obtained using this equation. The Linear Guide service life can be calculated by using the following equation if the stroke length and the number of reciprocating cycles are constant)

【 f_h : Hardness factor 】

To ensure achievement of the optimum load-bearing capacity of the Linear Guide, the raceway hardness must be 58~64 HRC. At a hardness below this range, the basic dynamic and static-load ratings decrease. The ratings must therefore be multiplied by the respective hardness factors (f_h). As the Linear Guide has sufficient hardness, f_h for the Linear Guide is 1.0 unless otherwise specified.

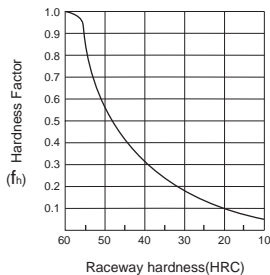

Fig 1.3.2 Hardness Factor (f_h)

【 f_t : Temperature factor 】

For Linear Guide used at ambient temperatures over 100°C, a temperature factor corresponding to the ambient temperature, selected from the diagram below, must be taken into consideration. In addition, please note that selected Linear Guide itself must be a model with high-temperature specifications.

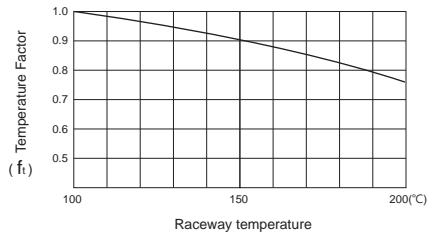

Fig 1.3.3 Temperature Factor (f_t)

※When used at ambient temperatures higher than 80°C, the seals, end caps, and ball cages used must be changed to those with high-temperature specifications.

ABOUT LINEAR GUIDE

1-3 Basic Load Rating and Service Life of Linear Guide

【 f_c : Contact factor】

When multiple Linear Guide blocks are laid by each other, moments and mounting-surface precision will affect operation, making it difficult to achieve uniform load distribution. For Linear Guide blocks used laid over one another, multiply the basic load rating (C), (C_0) by a contact factor selected from the table below.

Table 1.3.2 Contact factor (f_c)

No. of Blocks Used	Contact Factor (f_c)
In normal use	1
2	0.81
3	0.72
4	0.66
5	0.61
6 or more	0.6

※ When the non-uniform load distribution can be predicted, as in a large system, consider using a contact factor.

【 f_w : Load factor】

In general, machines in reciprocal motion are likely to cause vibration and impact during operation, and it is particularly difficult to determine the magnitude of vibration that develops during high-speed operation as well as that of impact during repeated starting and stopping in normal use. Therefore, where the effects of speed and vibration are estimated to be significant divide the basic dynamic-load rating (C) by a load factor selected from the table below.

Table 1.3.3 Load Factor (f_w)

Vibration and Impact	Velocity(V)	f_w
Very Slight	Very Low $V \leq 0.25$ m/s	1~1.2
Slight	Low $0.25 < V \leq 1$ m/s	1.2~1.5
Moderate	Medium $1 < V \leq 2$ m/s	1.5~2
Strong	High $V > 2$ m/s	2~3.5

Calculation Examples :

Application : Machine Center

Block model number : TRH30FE

(Basic static load $C_0 = 88.329$ kN, Basic dynamic load $C = 47$ kN)

The calculated load $P_c = 2614$ N

The formula of calculating the life time by travel is

$$L = \left(\frac{f_H \cdot f_T \cdot f_c}{f_w} \cdot \frac{C}{P_c} \right)^3 \cdot 50 \text{ km}$$

Since using only one block in this application, we take $f_c = 1$

Supposed the speed is not very high between 0.25~1 m/s, so we take $f_w = 1.5$

The temperature of working environment is under 100°C. The temperature factor $f_t = 1$

The hardness of raceway is 58~64 HRC, so the hardness $f_H = 1$

With all above data, the life time by travel of this application $L = 86,112$ km

To calculate the life time by using hours :

We supposed the distance of travel $L_s = 3000$ mm

Times (Back and forth) per mins $N1 = 4$ (min^{-1})

The life time by travel is 86,112 km, the distance of travel is 3 m (3000mm), so each back and forth is 6 m.

The total times of back and forth would be $86,112 \times 1000/6 = 14,352,000$

The life time by using minutes is $14,352,000/4 = 3,588,000$ mins = 59,800 hours

■ 1-3-7 Service-Life Equation L_h

The Service Life can be calculated by operating term and velocity Nominal Life.

$$L_h = \left(\frac{L \cdot 10^3}{V_e \cdot 60} \right) = \frac{\left(\frac{C}{P} \right)^3 \cdot 50 \cdot 10^3}{V_e \cdot 60} \cdot \text{hr}$$

L_h : Service Life in Hour L : Nominal life (km)

V_e : Velocity (m/min) C/P : Load Ratio

Calculating Life Time

Formula (A) calculating hour

L_n : Lifetime (h)
 L : Nominal life (km)
 L_s : Distance of travel (mm)
 N_1 : Times of travel per minute (min^{-1})

$$L_n = \frac{L \cdot 10^6}{2 \cdot L_s \cdot N_1 \cdot 60}$$

Formula (B) calculating year

L_y : Lifetime (year)
 L : Nominal life (km)
 L_s : Distance of travel (mm)
 N_1 : Times of travel per minute (min^{-1})
 M_n : Minutes of running per day (min/hr)
 H_n : Hours of running per day (hr/day)
 D_n : Days of running per year (day/year)

$$L_y = \frac{L \cdot 10^6}{2 \cdot L_s \cdot N_1 \cdot M_n \cdot H_n \cdot D_n}$$

Notes : The service life is verified by different environments and other usage conditions. Please confirm this information with the customer. For environment factors, please refer to page A08~A10.

ABOUT LINEAR GUIDE

1-3 Basic Load Rating and Service Life of Linear Guide

Example 1 :

There is a working station using linear guides with a nominal life of 45000 km, how should we calculate its service life in hours.

Known :

L_s : Distance of travel = 3000 mm (mm)

N_1 : 4 times of travel per minute (min^{-1})

$$L_n = \frac{L \cdot 10^6}{2 \cdot L_s \cdot N_1 \cdot 60} = \frac{45000 \cdot 10^6}{2 \cdot 3000 \cdot 4 \cdot 60} = 31250 \text{ hr}$$

Example 2 :

There is a working station using linear guides with a nominal life 71231.5 km, how should we calculate its service life in year.

Known :

L_s : Distance of travel = 4000 mm (mm)

N_1 : 5 times of travel per minute (min^{-1})

M_s : Running 60 mins per hour (min/hr)

H_s : Running 24 hours per day (hr/day)

D_s : Running 360 days per year (day/year)

$$L_y = \frac{L \cdot 10^6}{2 \cdot L_s \cdot N_1 \cdot M_s \cdot H_s \cdot D_s} = \frac{71231.5 \cdot 10^6}{2 \cdot 4000 \cdot 5 \cdot 60 \cdot 24 \cdot 360} = 3.435 \text{ year}$$

1-4 Friction

The construction of Linear Guide are block, rail and motion system which has rolling elements, such as balls and rollers, placed between two raceways. The rolling motion that rolling elements give rise to reduce the frictional resistance to 1/20 th to 1/40 th of that in a slide guide. Static friction, in particular, is much lower in a linear motion system than in other system, and there is little difference between static and dynamic friction, so that stick-slip does not occur. Therefore, Linear Guide could apply in various precision motion system. Frictional resistance in a linear motion system varies with the type of linear motion system, the magnitude of the preload, the viscosity resistance of the lubricant used the load exerted on the system, and other factors. Table shows Friction of Linear Guide.

Table 1.4.1 Friction Coefficient μ of Various Linear Motion Systems μ

Type of Linear Motion System	Friction Coefficient
Linear Guide	0.002~0.003
Ball Spline	0.002~0.003
Linear Guide Roller	0.0050~0.010
Cross Roller Guide	0.0010~0.0025
Linear Ball Slide	0.0006~0.0012

ABOUT LINEAR GUIDE

1-5 Working Load

■ 1-5-1 Working Load

The load applied to the Linear Guide, varies with the external force exerted thereon, such as the location of the center of gravity of an object been moved, the location of the thrust developed, inertia due to acceleration and deceleration during starting and stopping, and the machining resistance. To select the correct type of Linear Guide, the magnitude of applied loads must be determined in consideration of the above conditions to calculate accurate applied load.

To obtain the magnitude of an applied load and the service life in hours, the operating conditions of the Linear Guide system must first be set.

- (1) Mass : m (kg)
- (2) Direction of the action load
- (3) Location of the action point
(e.g., center of gravity) : L_2, L_3, h_1 (mm)
- (4) Location of the thrust developed : L_4, h_2 (mm)
- (5) Linear Guide system arrangement : L_0, L_1 (mm)
- (6) Velocity diagram
- (7) Duty cycle (No. of reciprocating cycles per min) : N_1 (min^{-1})
- (8) Stroke length : L (mm)
- (9) Mean velocity : V_m (mm/s)
- (10) Required service life in hours : L_h (h)

Velocity : V (mm/s)

Time constant : t_n (s)

Acceleration : a_n (mm/s^2)

$$a_n = \left(\frac{V}{t_n} \right)$$

Gravitational acceleration $g = 9.8 \text{ m/s}^2$

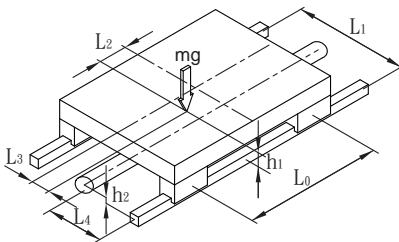

Fig 1.5.1

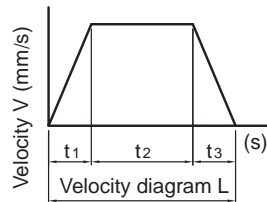

Fig 1.5.2

Calculating the Working Load

The load applied to the Linear Guide varies with the external force exerted thereon, such as the location of the center of gravity of an object being moved, the location of the thrust developed, inertia due to acceleration and deceleration during starting and stopping, and the machining resistance. To select the correct type of Linear Guide, the magnitude of applied loads must be determined in consideration of the above conditions. Using the following Table 1.5.1, we will now calculate the loads applied to the Linear Guide.

m : Mass	(kg)	g : Gravitational acceleration	(m/s^2)
L_n : Distance	(mm)	($g=9.8m/s^2$)	
F_n : External force	(N)	V : Velocity	(m/s)
P_n : Applied load	(N)	t_n : Time constant	(s)
(radial and reverse-radial directions)		a_n : Acceleration	(m/s^2)
P_{nr} : Applied load	(N)	$a_n = \left(\frac{V}{t_n} \right)$	

Table 1.5.1 Calculation Load

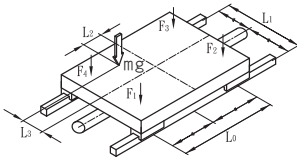
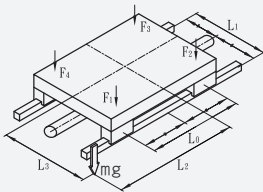
No.	Operating Conditions	Equation for Calculating Applied Load
1	Install in a horizontal position. (Move the block) Measure in uniform motion or at rest. 	$F_1 = \frac{mg}{4} + \frac{mg \cdot L_2}{2 \cdot L_0} - \frac{mg \cdot L_3}{2 \cdot L_1}$ $F_2 = \frac{mg}{4} - \frac{mg \cdot L_2}{2 \cdot L_0} - \frac{mg \cdot L_3}{2 \cdot L_1}$ $F_3 = \frac{mg}{4} - \frac{mg \cdot L_2}{2 \cdot L_0} + \frac{mg \cdot L_3}{2 \cdot L_1}$ $F_4 = \frac{mg}{4} + \frac{mg \cdot L_2}{2 \cdot L_0} + \frac{mg \cdot L_3}{2 \cdot L_1}$
2	Install in an overhung horizontal position. (Move the block) Measure in uniform motion or at rest. 	$F_1 = \frac{mg}{4} + \frac{mg \cdot L_2}{2 \cdot L_0} + \frac{mg \cdot L_3}{2 \cdot L_1}$ $F_2 = \frac{mg}{4} - \frac{mg \cdot L_2}{2 \cdot L_0} + \frac{mg \cdot L_3}{2 \cdot L_1}$ $F_3 = \frac{mg}{4} - \frac{mg \cdot L_2}{2 \cdot L_0} - \frac{mg \cdot L_3}{2 \cdot L_1}$ $F_4 = \frac{mg}{4} + \frac{mg \cdot L_2}{2 \cdot L_0} - \frac{mg \cdot L_3}{2 \cdot L_1}$

ABOUT LINEAR GUIDE

1-5 Working Load

A

Linear Guide

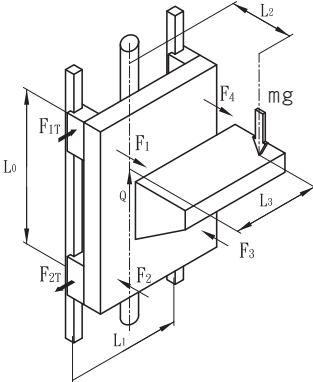
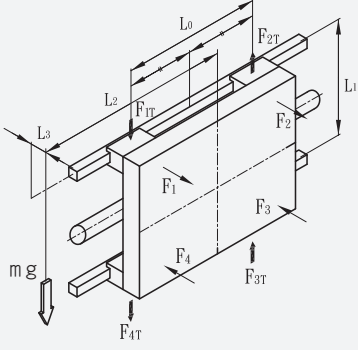
No.	Operating Conditions	Equation for Calculating Applied Load
3	<p>Install in a vertical position. Measure in uniform motion or at rest.</p>  <p>(EX) On the vertical axis of industrial robots in automatic painting machines and lifters</p>	$F_1 = F_2 = F_3 = F_4 = \frac{mg \cdot L_2}{2 \cdot L_0}$ $F_{1T} = F_{2T} = F_{3T} = F_{4T} = \frac{mg \cdot L_3}{2 \cdot L_0}$
4	<p>On a wall. Measure in uniform motion or at rest.</p>  <p>(EX) On cross rails loader travel axis</p>	$F_1 = F_2 = F_3 = F_4 = \frac{mg \cdot L_3}{2 \cdot L_1}$ $F_{1T} = F_{4T} = \frac{mg}{4} + \frac{mg \cdot L_2}{2 \cdot L_0}$ $F_{2T} = F_{3T} = \frac{mg}{4} - \frac{mg \cdot L_2}{2 \cdot L_0}$

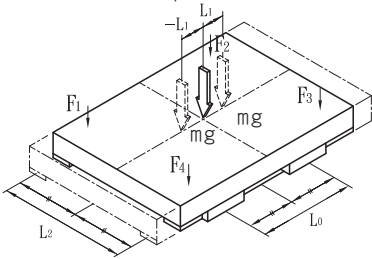
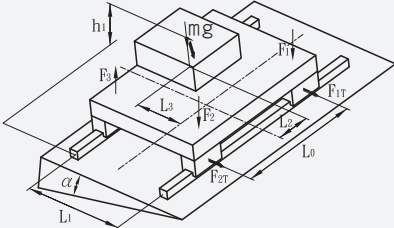
No.	Operating Conditions	Equation for Calculating Applied Load
5	<p>Move on Linear Guide rail Install in a horizontal position.</p>  <p>(EX) X - Y table/Sliding fork</p>	$F_{1\max}=F_{2\max}=F_{3\max}=F_{4\max}=\frac{mg}{4}+\frac{mg\cdot L_1}{2\cdot L_0}$ $F_{1\min}=F_{2\min}=F_{3\min}=F_{4\min}=\frac{mg}{4}-\frac{mg\cdot L_1}{2\cdot L_0}$
6	<p>Install in a laterally tilted position.</p>  <p>(EX) NC lathe/Carriage (for the lathe)</p>	$F_{1T}=\frac{mg\cdot\cos\theta}{4}+\frac{mg\cdot\cos\theta\cdot L_2}{2\cdot L_0}-\frac{mg\cdot\cos\theta\cdot L_3}{2\cdot L_1}+\frac{mg\cdot\sin\theta\cdot h_1}{2\cdot L_1}$ $F_{2T}=\frac{mg\cdot\sin\theta}{4}+\frac{mg\cdot\sin\theta\cdot L_2}{2\cdot L_0}-\frac{mg\cdot\cos\theta}{4}-\frac{mg\cdot\cos\theta\cdot L_2}{2\cdot L_0}-\frac{mg\cdot\cos\theta\cdot L_3}{2\cdot L_1}+\frac{mg\cdot\sin\theta\cdot h_1}{2\cdot L_1}$ $F_{3T}=\frac{mg\cdot\cos\theta}{4}-\frac{mg\cdot\cos\theta\cdot L_2}{2\cdot L_0}+\frac{mg\cdot\cos\theta\cdot L_3}{2\cdot L_1}-\frac{mg\cdot\sin\theta\cdot h_1}{2\cdot L_1}$ $F_{4T}=\frac{mg\cdot\sin\theta}{4}-\frac{mg\cdot\sin\theta\cdot L_2}{2\cdot L_0}+\frac{mg\cdot\cos\theta}{4}+\frac{mg\cdot\cos\theta\cdot L_2}{2\cdot L_0}+\frac{mg\cdot\cos\theta\cdot L_3}{2\cdot L_1}-\frac{mg\cdot\sin\theta\cdot h_1}{2\cdot L_1}$

ABOUT LINEAR GUIDE

1-5 Working Load

A

Linear Guide

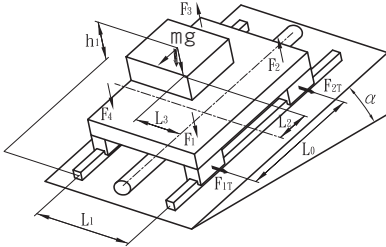
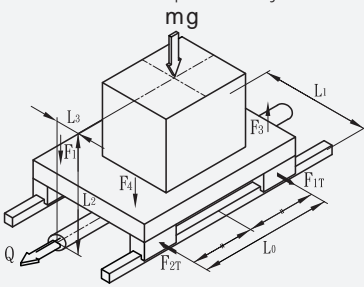
No.	Operating Conditions	Equation for Calculating Applied Load
7	<p>Install in a longitudinally tilted position.</p>  <p>(EX) NC lathe/Tool res (for the lathe)</p>	$F_{1=} + \frac{mg \cdot \cos \theta}{4} + \frac{mg \cdot \cos \theta \cdot L_2}{2 \cdot L_0}$ $- \frac{mg \cdot \cos \theta \cdot L_3}{2 \cdot L_1} + \frac{mg \cdot \sin \theta \cdot h_1}{2 \cdot L_0}$ $F_{1T=} + \frac{mg \cdot \sin \theta \cdot L_3}{2 \cdot L_0}$ $F_{2=} + \frac{mg \cdot \cos \theta}{4} - \frac{mg \cdot \cos \theta \cdot L_2}{2 \cdot L_0}$ $- \frac{mg \cdot \cos \theta \cdot L_3}{2 \cdot L_1} - \frac{mg \cdot \sin \theta \cdot h_1}{2 \cdot L_0}$ $F_{2T=} - \frac{mg \cdot \sin \theta \cdot L_3}{2 \cdot L_0}$ $F_{3=} + \frac{mg \cdot \cos \theta}{4} - \frac{mg \cdot \cos \theta \cdot L_2}{2 \cdot L_0}$ $+ \frac{mg \cdot \cos \theta \cdot L_3}{2 \cdot L_1} - \frac{mg \cdot \sin \theta \cdot h_1}{2 \cdot L_0}$ $F_{3T=} - \frac{mg \cdot \sin \theta \cdot L_3}{2 \cdot L_0}$ $F_{4=} + \frac{mg \cdot \cos \theta}{4} + \frac{mg \cdot \cos \theta \cdot L_2}{2 \cdot L_0}$ $+ \frac{mg \cdot \cos \theta \cdot L_3}{2 \cdot L_1} + \frac{mg \cdot \sin \theta \cdot h_1}{2 \cdot L_0}$ $F_{4T=} + \frac{mg \cdot \sin \theta \cdot L_3}{2 \cdot L_0}$
8	<p>Install in a horizontal position subjected to inertia.</p>  <p>(EX) Wagon Truck</p>	$F_1 = F_4 = \frac{mg}{4} - \frac{mg \cdot a_1 \cdot L_2}{2 \cdot L_0 \cdot g}$ $F_2 = F_3 = \frac{mg}{4} + \frac{mg \cdot a_1 \cdot L_2}{2 \cdot L_0 \cdot g}$ $F_{1T} = F_{2T} = F_{3T} = F_{4T} = \frac{mg \cdot a_1 \cdot L_3}{2 \cdot L_0 \cdot g}$ $F_1 = F_2 = F_3 = F_4 = \frac{mg}{4}$ $F_1 = F_4 = \frac{mg}{4} - \frac{mg \cdot a_3 \cdot L_2}{2 \cdot L_0 \cdot g}$ $F_2 = F_3 = \frac{mg}{4} + \frac{mg \cdot a_3 \cdot L_2}{2 \cdot L_0 \cdot g}$ $F_{1T} = F_{2T} = F_{3T} = F_{4T} = \frac{mg \cdot a_3 \cdot L_3}{2 \cdot L_0 \cdot g}$

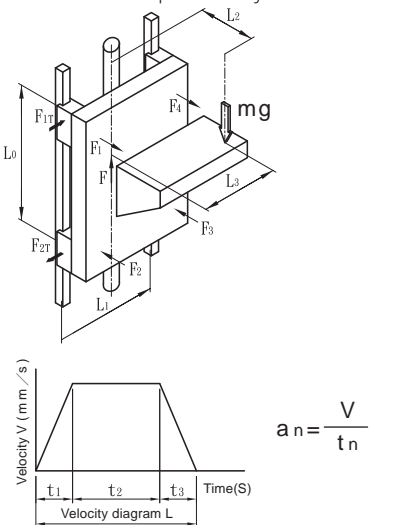
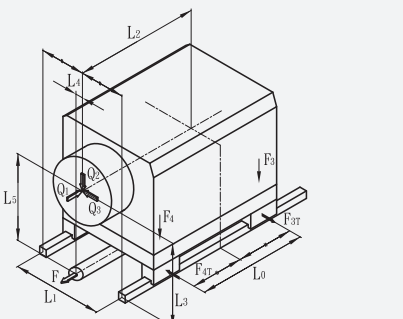
No.	Operating Conditions	Equation for Calculating Applied Load
9	<p>Mount in a vertical position subjected to inertia.</p>  <p>(EX) Elevator.</p>	$F_1 = F_2 = F_3 = F_4 = \frac{(mg + mg \cdot a_1 / g) \cdot L_2}{2 \cdot L_0}$ $F_{1T} = F_{2T} = F_{3T} = F_{4T} = \frac{(mg + mg \cdot a_1 / g) \cdot L_3}{2 \cdot L_0}$ $F_1 = F_2 = F_3 = F_4 = \frac{mg \cdot L_2}{2 \cdot L_0}$ $F_{1T} = F_{2T} = F_{3T} = F_{4T} = \frac{mg \cdot L_3}{2 \cdot L_0}$ $F_1 = F_2 = F_3 = F_4 = \frac{(mg - mg \cdot a_3 / g) \cdot L_2}{2 \cdot L_0}$ $F_{1T} = F_{2T} = F_{3T} = F_{4T} = \frac{(mg - mg \cdot a_3 / g) \cdot L_3}{2 \cdot L_0}$
10	<p>Install on a horizontal position subjected to external force.</p> 	$F_1 = F_2 = F_3 = F_4 = \frac{Q_1 \cdot L_5}{2 \cdot L_0}$ $F_{1T} = F_{2T} = F_{3T} = F_{4T} = \frac{Q_1 \cdot L_4}{2 \cdot L_0}$ $F_1 = F_4 = \frac{Q_2}{4} + \frac{Q_2 \cdot L_2}{2 \cdot L_0}$ $F_2 = F_3 = \frac{Q_2}{4} - \frac{Q_2 \cdot L_2}{2 \cdot L_0}$ $F_1 = F_2 = F_3 = F_4 = \frac{Q_3 \cdot L_3}{2 \cdot L_1}$ $F_{1T} = F_{4T} = \frac{Q_3}{4} + \frac{Q_3 \cdot L_2}{2 \cdot L_0}$ $F_{2T} = F_{3T} = \frac{Q_3}{4} - \frac{Q_3 \cdot L_2}{2 \cdot L_0}$

ABOUT LINEAR GUIDE

1-6 Safety Factor and Load

■ 1-6-1 Equivalent Factors of Linear Guide Block

Where a sufficient installation space is not available you may be obliged to use just one Linear Guide block or two Linear Guide blocks laid over one another for the Linear Guide. In such a setting, the load distribution cannot be uniform, as a result, an excessive load is exerted in localized areas (e.g., rail ends). Continued use under such conditions may result in flaking in those areas, consequently shortening the service life. In such a case, calculating true load by multiplying the moment value by any one of the moment-equivalent factors specified in Tables.

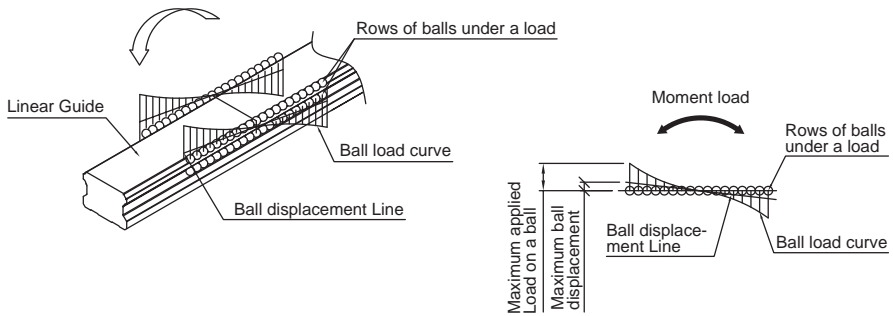

Fig 1.6.1 Ball Load Effectuated by a Moment

An equivalent-load equation applicable when a moment acts on a Linear Guides is shown below.

$$P = K \cdot M$$

P : Equivalent load per Linear Guide (kgf)

K : Equivalent moment factor (mm^{-1})

M : Developed moment (kgf · mm)

K_A , K_B , K_C represent the equivalent moment factors in directions M_A , M_B , M_C respectively.

Calculation Examples

Two Linear Guide blocks are used laid over one another.

Model No : TRH30FE

Gravitational Acceleration $g = 9.8 \text{ m/s}$

Mass $w = 5 \text{ kgf}$

$M_c = 5 \cdot 150 = 750 \text{ (kgf-mm)}$

$M_A = 5 \cdot 200 = 1000 \text{ (kgf-mm)}$

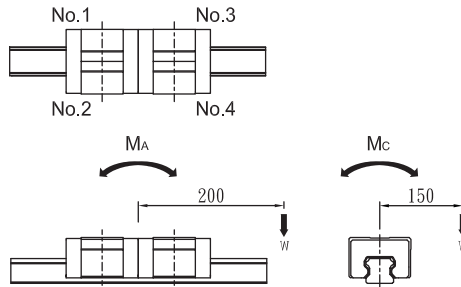

Fig 1.6.2

$$P_1 = K_c \cdot \frac{M_c}{2} + K_A \cdot M_A + \frac{W}{2} = 7.15 \cdot 10^{-2} \cdot \frac{750}{2} + 1.3 \cdot 10^{-2} \cdot 1000 + \frac{5}{2} = 42.3 \text{ (kgf)}$$

$$P_2 = -K_c \cdot \frac{M_c}{2} + K_A \cdot M_A + \frac{W}{2} = -7.15 \cdot 10^{-2} \cdot \frac{750}{2} + 1.3 \cdot 10^{-2} \cdot 1000 + \frac{5}{2} = -11.3 \text{ (kgf)}$$

$$P_3 = K_c \cdot \frac{M_c}{2} - K_A \cdot M_A + \frac{W}{2} = 7.15 \cdot 10^{-2} \cdot \frac{750}{2} - 1.3 \cdot 10^{-2} \cdot 1000 + \frac{5}{2} = 16.3 \text{ (kgf)}$$

$$P_4 = -K_c \cdot \frac{M_c}{2} - K_A \cdot M_A + \frac{W}{2} = -7.15 \cdot 10^{-2} \cdot \frac{750}{2} - 1.3 \cdot 10^{-2} \cdot 1000 + \frac{5}{2} = -37.3 \text{ (kgf)}$$

※ Note.1

Since a Linear Guide in a vertical position receives only a moment load, there is no need to apply other loads (w).

※ Note.2

In some models, load ratings differ depending on the direction of the applied load. With such a model, calculate an equivalent load in a direction in which conditions are comparably bad.

ABOUT LINEAR GUIDE

1-6 Safety Factor and Load

Table 1.6.1 TRH-V

ModelNo.	Equivalent Factors $K_a(\text{mm}^{-1})$		Equivalent Factors $K_b(\text{mm}^{-1})$		Equivalent Factors $K_c(\text{mm}^{-1})$
	Equivalent Load Calculation for a system Using One Linear Guide Block	Equivalent Load Calculation for a system Using Two Linear Guide Blocks laid Over One-Another	Equivalent Load Calculation for a system Using One Linear Guide Block	Equivalent Load Calculation for a system Using Two Linear Guide Blocks laid Over One-Another	
TRH15VN	1.48×10^{-1}	3.11×10^{-2}	1.48×10^{-1}	3.11×10^{-2}	1.34×10^{-1}
TRH15VL	1.26×10^{-1}	2.70×10^{-2}	1.26×10^{-1}	2.70×10^{-2}	1.34×10^{-1}
TRH20VN	1.11×10^{-1}	2.35×10^{-2}	1.11×10^{-1}	2.35×10^{-2}	9.90×10^{-2}
TRH20VE	8.00×10^{-2}	1.78×10^{-2}	8.00×10^{-2}	1.78×10^{-2}	9.90×10^{-2}
TRH25VN	1.04×10^{-1}	2.17×10^{-2}	1.04×10^{-1}	2.17×10^{-2}	8.62×10^{-2}
TRH25VE	7.35×10^{-2}	1.60×10^{-2}	7.35×10^{-2}	1.60×10^{-2}	8.62×10^{-2}
TRH30VN	6.52×10^{-2}	1.34×10^{-2}	6.52×10^{-2}	1.34×10^{-2}	7.69×10^{-2}
TRH30VE	6.12×10^{-2}	1.33×10^{-2}	6.12×10^{-2}	1.33×10^{-2}	7.15×10^{-2}
TRH35VN	6.95×10^{-2}	1.43×10^{-2}	6.95×10^{-2}	1.43×10^{-2}	6.29×10^{-2}
TRH35VE	5.25×10^{-2}	1.15×10^{-2}	5.25×10^{-2}	1.15×10^{-2}	5.85×10^{-2}
TRH45VL	5.80×10^{-2}	1.24×10^{-2}	5.80×10^{-2}	1.24×10^{-2}	4.38×10^{-2}
TRH45VE	4.59×10^{-2}	1.00×10^{-2}	4.59×10^{-2}	1.00×10^{-2}	4.38×10^{-2}
TRH55VL	5.25×10^{-2}	1.07×10^{-2}	5.25×10^{-2}	1.07×10^{-2}	3.78×10^{-2}
TRH55VE	4.08×10^{-2}	8.69×10^{-3}	4.08×10^{-2}	8.69×10^{-3}	3.78×10^{-2}
TRH65VL	4.52×10^{-2}	8.76×10^{-3}	4.52×10^{-2}	8.76×10^{-3}	3.24×10^{-2}
TRH65VE	3.27×10^{-2}	6.77×10^{-3}	3.27×10^{-2}	6.77×10^{-3}	3.24×10^{-2}

K_a : Equivalent moment factor in the pitching direction.

K_b : Equivalent moment factor in the yawing direction.

K_c : Equivalent moment factor in the rolling direction.

Table 1.6.2 TRH-F

Model No.	Equivalent Factors $K_a(\text{mm}^{-1})$		Equivalent Factors $K_b(\text{mm}^{-1})$		Equivalent Factors $K_c(\text{mm}^{-1})$
	Equivalent Load Calculation for a system Using One Linear Guide Block	Equivalent Load Calculation for a system Using Two Linear Guide Blocks laid Over One-Another	Equivalent Load Calculation for a system Using One Linear Guide Block	Equivalent Load Calculation for a system Using Two Linear Guide Blocks laid Over One-Another	
TRH15FN	1.48×10^{-1}	3.11×10^{-2}	1.48×10^{-1}	3.11×10^{-2}	1.34×10^{-1}
TRH15FL	1.26×10^{-1}	2.70×10^{-2}	1.26×10^{-1}	2.70×10^{-2}	1.34×10^{-1}
TRH20FN	1.11×10^{-1}	2.35×10^{-2}	1.11×10^{-1}	2.35×10^{-2}	9.90×10^{-2}
TRH20FE	8.00×10^{-2}	1.78×10^{-2}	8.00×10^{-2}	1.78×10^{-2}	9.90×10^{-2}
TRH25FN	1.04×10^{-1}	2.17×10^{-2}	1.04×10^{-1}	2.17×10^{-2}	8.62×10^{-2}
TRH25FE	7.35×10^{-2}	1.60×10^{-2}	7.35×10^{-2}	1.60×10^{-2}	8.62×10^{-2}
TRH30FN	6.52×10^{-2}	1.34×10^{-2}	6.52×10^{-2}	1.34×10^{-2}	7.69×10^{-2}
TRH30FE	6.12×10^{-2}	1.33×10^{-2}	6.12×10^{-2}	1.33×10^{-2}	7.15×10^{-2}
TRH35FN	6.95×10^{-2}	1.43×10^{-2}	6.95×10^{-2}	1.43×10^{-2}	6.29×10^{-2}
TRH35FE	5.25×10^{-2}	1.15×10^{-2}	5.25×10^{-2}	1.15×10^{-2}	5.85×10^{-2}
TRH45FL	5.80×10^{-2}	1.24×10^{-2}	5.80×10^{-2}	1.24×10^{-2}	4.38×10^{-2}
TRH45FE	4.59×10^{-2}	1.00×10^{-2}	4.59×10^{-2}	1.00×10^{-2}	4.38×10^{-2}
TRH55FL	5.25×10^{-2}	1.07×10^{-2}	5.25×10^{-2}	1.07×10^{-2}	3.78×10^{-2}
TRH55FE	4.08×10^{-2}	8.69×10^{-3}	4.08×10^{-2}	8.69×10^{-3}	3.78×10^{-2}
TRH65FL	4.52×10^{-2}	8.76×10^{-3}	4.52×10^{-2}	8.76×10^{-3}	3.24×10^{-2}
TRH65FE	3.27×10^{-2}	6.77×10^{-3}	3.27×10^{-2}	6.77×10^{-3}	3.24×10^{-2}

K_a : Equivalent moment factor in the pitching direction.

K_b : Equivalent moment factor in the yawing direction.

K_c : Equivalent moment factor in the rolling direction.

ABOUT LINEAR GUIDE

1-6 Safety Factor and Load

Table 1.6.3 TRS-V

Model No.	Equivalent Factors $K_a(\text{mm}^{-1})$		Equivalent Factors $K_b(\text{mm}^{-1})$		Equivalent Factors $K_c(\text{mm}^{-1})$
	Equivalent Load Calculation for a system Using One Linear Guide Block	Equivalent Load Calculation for a system Using Two Linear Guide Blocks laid Over One-Another	Equivalent Load Calculation for a system Using One Linear Guide Block	Equivalent Load Calculation for a system Using Two Linear Guide Blocks laid Over One-Another	
TRS15VS	2.29×10^{-1}	4.39×10^{-2}	2.29×10^{-1}	4.39×10^{-2}	1.34×10^{-1}
TRS15VN	1.48×10^{-1}	3.11×10^{-2}	1.48×10^{-1}	3.11×10^{-2}	1.34×10^{-1}
TRS20VS	2.00×10^{-1}	3.58×10^{-2}	2.00×10^{-1}	3.58×10^{-2}	9.90×10^{-2}
TRS20VN	1.25×10^{-1}	2.60×10^{-2}	1.25×10^{-1}	2.60×10^{-2}	9.90×10^{-2}
TRS25VS	1.60×10^{-1}	3.07×10^{-2}	1.60×10^{-1}	3.07×10^{-2}	8.62×10^{-2}
TRS25VN	1.04×10^{-1}	2.17×10^{-2}	1.04×10^{-1}	2.17×10^{-2}	8.62×10^{-2}
TRS30VS	1.47×10^{-1}	2.57×10^{-2}	1.47×10^{-1}	2.57×10^{-2}	7.15×10^{-2}
TRS30VN	8.65×10^{-2}	1.82×10^{-2}	8.65×10^{-2}	1.82×10^{-2}	7.15×10^{-2}
TRS35VS	1.26×10^{-1}	2.30×10^{-2}	1.26×10^{-1}	2.30×10^{-2}	5.85×10^{-2}
TRS35VN	7.87×10^{-2}	1.61×10^{-2}	7.87×10^{-2}	1.61×10^{-2}	5.85×10^{-2}
TRS35VE	5.25×10^{-2}	1.15×10^{-2}	5.25×10^{-2}	1.15×10^{-2}	5.85×10^{-2}
TRS45VN	6.89×10^{-2}	1.39×10^{-2}	6.89×10^{-2}	1.39×10^{-2}	4.38×10^{-2}

K_a : Equivalent moment factor in the pitching direction.

K_b : Equivalent moment factor in the yawing direction.

K_c : Equivalent moment factor in the rolling direction.

Table 1.6.4 TRS-F

Model No.	Equivalent Factors $K_a(\text{mm}^{-1})$		Equivalent Factors $K_b(\text{mm}^{-1})$		Equivalent Factors $K_c(\text{mm}^{-1})$
	Equivalent Load Calculation for a system Using One Linear Guide Block	Equivalent Load Calculation for a system Using Two Linear Guide Blocks laid Over One-Another	Equivalent Load Calculation for a system Using One Linear Guide Block	Equivalent Load Calculation for a system Using Two Linear Guide Blocks laid Over One-Another	
TRS15FS	2.29×10^{-1}	4.39×10^{-2}	2.29×10^{-1}	4.39×10^{-2}	1.34×10^{-1}
TRS15FN	1.48×10^{-1}	3.11×10^{-2}	1.48×10^{-1}	3.11×10^{-2}	1.34×10^{-1}
TRS20FS	2.00×10^{-1}	3.58×10^{-2}	2.00×10^{-1}	3.58×10^{-2}	9.90×10^{-2}
TRS20FN	1.25×10^{-1}	2.60×10^{-2}	1.25×10^{-1}	2.60×10^{-2}	9.90×10^{-2}
TRS25FN	1.04×10^{-1}	2.17×10^{-2}	1.04×10^{-1}	2.17×10^{-2}	8.62×10^{-2}

K_a : Equivalent moment factor in the pitching direction.

K_b : Equivalent moment factor in the yawing direction.

K_c : Equivalent moment factor in the rolling direction.

Table 1.6.5 TRC-V

Model No.	Equivalent Factors $K_a(\text{mm}^{-1})$		Equivalent Factors $K_b(\text{mm}^{-1})$		Equivalent Factors $K_c(\text{mm}^{-1})$
	Equivalent Load Calculation for a system Using One Linear Guide Block	Equivalent Load Calculation for a system Using Two Linear Guide Blocks laid Over One-Another	Equivalent Load Calculation for a system Using One Linear Guide Block	Equivalent Load Calculation for a system Using Two Linear Guide Blocks laid Over One-Another	
TRC25VE	7.35×10^{-2}	1.60×10^{-2}	7.35×10^{-2}	1.60×10^{-2}	8.62×10^{-2}

K_a : Equivalent moment factor in the pitching direction.

K_b : Equivalent moment factor in the yawing direction.

K_c : Equivalent moment factor in the rolling direction.

ABOUT LINEAR GUIDE

1-6 Safety Factor and Load

Table 1.6.6 TM-N

Model No.	Equivalent Factors $K_a(\text{mm}^{-1})$		Equivalent Factors $K_b(\text{mm}^{-1})$		Equivalent Factors $K_c(\text{mm}^{-1})$
	Equivalent Load Calculation for a system Using One Linear Guide Block	Equivalent Load Calculation for a system Using Two Linear Guide Blocks laid Over One-Another	Equivalent Load Calculation for a system Using One Linear Guide Block	Equivalent Load Calculation for a system Using Two Linear Guide Blocks laid Over One-Another	
TM07NN	8.88×10^{-1}	6.31×10^{-2}	8.88×10^{-1}	6.31×10^{-2}	2.74×10^{-1}
TM07NL	4.41×10^{-1}	5.16×10^{-2}	4.41×10^{-1}	5.16×10^{-2}	2.74×10^{-1}
TM09NN	4.41×10^{-1}	5.26×10^{-2}	4.41×10^{-1}	5.26×10^{-2}	2.19×10^{-1}
TM09NL	2.76×10^{-1}	4.08×10^{-2}	2.76×10^{-1}	4.08×10^{-2}	2.19×10^{-1}
TM12NN	4.90×10^{-1}	4.32×10^{-2}	4.90×10^{-1}	4.32×10^{-2}	1.64×10^{-1}
TM12NL	2.67×10^{-1}	3.42×10^{-2}	2.67×10^{-1}	3.42×10^{-2}	1.64×10^{-1}
TM15NN	3.60×10^{-1}	3.61×10^{-2}	3.60×10^{-1}	3.61×10^{-2}	1.32×10^{-1}
TM15NL	1.94×10^{-1}	2.76×10^{-2}	1.94×10^{-1}	2.76×10^{-2}	1.32×10^{-1}

K_a : Equivalent moment factor in the pitching direction.

K_b : Equivalent moment factor in the yawing direction.

K_c : Equivalent moment factor in the rolling direction.

Table 1.6.7 TM-W

Model No.	Equivalent Factors $K_a(\text{mm}^{-1})$		Equivalent Factors $K_b(\text{mm}^{-1})$		Equivalent Factors $K_c(\text{mm}^{-1})$
	Equivalent Load Calculation for a system Using One Linear Guide Block	Equivalent Load Calculation for a system Using Two Linear Guide Blocks laid Over One-Another	Equivalent Load Calculation for a system Using One Linear Guide Block	Equivalent Load Calculation for a system Using Two Linear Guide Blocks laid Over One-Another	
TM09WN	2.27×10^{-1}	3.01×10^{-2}	2.27×10^{-1}	3.01×10^{-2}	7.92×10^{-2}
TM09WL	1.30×10^{-1}	2.17×10^{-2}	1.30×10^{-1}	2.17×10^{-2}	7.14×10^{-2}
TM12WN	1.85×10^{-1}	2.28×10^{-2}	1.85×10^{-1}	2.28×10^{-2}	5.20×10^{-2}
TM12WL	1.12×10^{-1}	1.72×10^{-2}	1.12×10^{-1}	1.72×10^{-2}	5.05×10^{-2}
TM15WN	1.56×10^{-1}	2.01×10^{-2}	1.56×10^{-1}	2.01×10^{-2}	3.24×10^{-2}
TM15WL	9.07×10^{-2}	1.47×10^{-2}	9.07×10^{-2}	1.47×10^{-2}	3.07×10^{-2}

K_a : Equivalent moment factor in the pitching direction.

K_b : Equivalent moment factor in the yawing direction.

K_c : Equivalent moment factor in the rolling direction.

■ 1-6-2 Calculating the Equivalent Load

The Linear Guide can bear loads and moments from all directions, including a radial load (P_R), reverse-radial load (P_L), and lateral load (P_T), simultaneously.

P_R : Radial load M_A : Moment in the pitching direction
 P_L : Reverse-radial load M_B : Moment in the yawing direction
 P_T : Lateral load M_C : Moment in the rolling direction

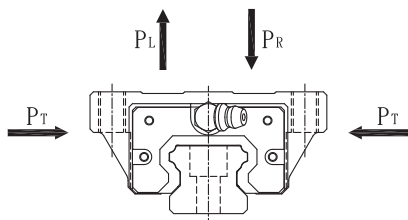

Fig 1.6.3 Directions of the Load and Moment Exerted on the Linear Guide

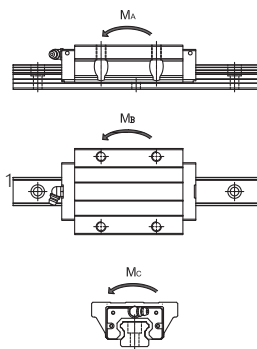

Fig 1.6.4

Equivalent load P_E

When more than one load (e.g., radial and lateral loads) is exerted on the Linear Guide simultaneously, the service life and static safety factors should be calculated by using equivalent load values obtained by converting all loads involved into radial, lateral, and other loads involved.

Equivalent-load equation

The Linear Guide can bear loads and moments from all directions, including a radial load (P_R), reverse-radial load (P_L) and lateral load (P_T) simultaneously.

When a radial load ($P_{R(L)}$) and a lateral (P_T) are applied simultaneously the equivalent load can be obtained by using the following equation.

$$P_E : (\text{equivalent load}) = X \cdot P_{R(L)} + Y \cdot P_T$$

$P_{R(L)}$: Radial load

P_T : Lateral load

$X, Y = 1$

ABOUT LINEAR GUIDE

1-7 Calculation of Average Working Load

1-7-1 Calculating the Mean Load

An industrial robot grasp a workpiece by its arm as it advances, moving forward with the load, when it returns, the arm has no load other than its tare. In a machine tool, Linear Guide blocks receive variable loads according to the host-system operating conditions. Therefore, the calculation of service life should take such fluctuation into consideration.

When the service life of a Linear Guide with variable load is equal to the one with certain load then that certain load is called the Mean Load (P_m).

$$P_m = \sqrt[3]{\frac{1}{L} \cdot \sum (P_n^3 \cdot L_n)}$$

- P_m : Mean load (N)
- P_n : Varying load (N)
- L_c : Total running distance (mm)
- L_n : Running distance under load P_n (mm)

(1) For Loads with Stepwise Change

$$P_m = \sqrt[3]{\frac{1}{L} (P_1^3 \cdot L_1 + P_2^3 \cdot L_2 + \dots + P_n^3 \cdot L_n)} \dots \dots \dots (1)$$

- P_m : Mean load (N)
- P_n : Varying load (N)
- L_c : Total running distance (mm)
- L_n : Running distance under load P_n (mm)

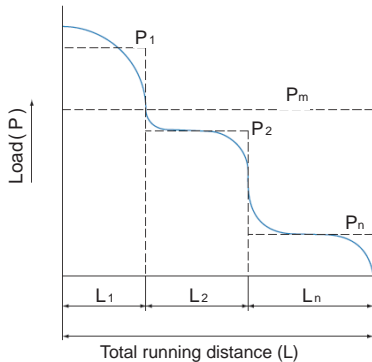

Fig 1.7.1

※ This equation and equation (1) below apply in cases in which the rolling elements are balls.

(2) For Loads with Monotonous Changes

$$P_m \doteq \frac{1}{3} (P_{\min} + 2 \cdot P_{\max}) \dots\dots\dots (2)$$

P_{\min} : minimum load (N)

P_{\max} : maximum load (N)

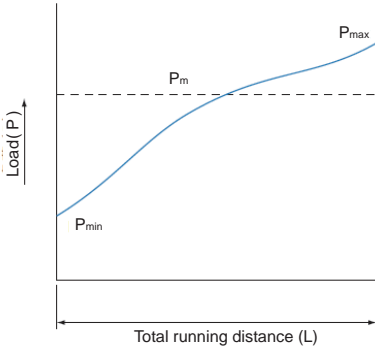

Fig 1.7.2

(3) For Loads with Sinusoidal Changes

$$P_m \doteq 0.65P_{\max} \dots\dots\dots (3)$$

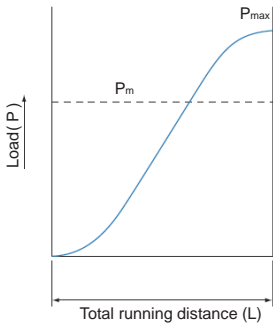

Fig 1.7.3

$$P_m \doteq 0.75P_{\max} \dots\dots\dots (4)$$

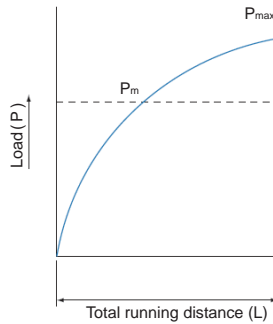

Fig 1.7.4

ABOUT LINEAR GUIDE

1-7 Calculation of Average Working Load

■ 1-7-2 Mean Load Calculation Example (I)

(1) Horizontal Installations are subjected to Acceleration and Deceleration

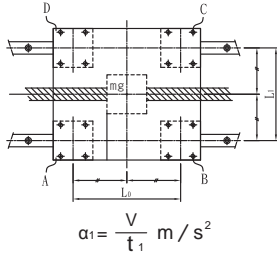

Fig 1.7.5

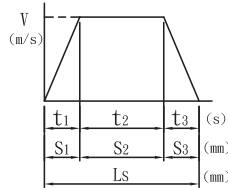

Fig 1.7.6

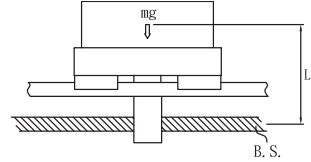

Fig 1.7.7

$$\alpha_1 = \frac{V}{t_1} \text{ m/s}^2$$

(2) Load Applied to the Linear Guide Block

1. During uniform motion
2. During acceleration
3. During deceleration

$$P_1 = + \frac{mg}{4}$$

$$P_2 = + \frac{mg}{4}$$

$$P_3 = + \frac{mg}{4}$$

$$P_4 = + \frac{mg}{4}$$

$$P_{a_1} = P_1 + \frac{m \cdot \alpha_1 \cdot L_s}{2 \cdot L_0}$$

$$P_{a_2} = P_2 + \frac{m \cdot \alpha_1 \cdot L_s}{2 \cdot L_0}$$

$$P_{a_3} = P_3 + \frac{m \cdot \alpha_1 \cdot L_s}{2 \cdot L_0}$$

$$P_{a_4} = P_4 + \frac{m \cdot \alpha_1 \cdot L_s}{2 \cdot L_0}$$

$$P_{d_1} = P_1 - \frac{m \cdot \alpha_1 \cdot L_s}{2 \cdot L_0}$$

$$P_{d_2} = P_2 - \frac{m \cdot \alpha_1 \cdot L_s}{2 \cdot L_0}$$

$$P_{d_3} = P_3 - \frac{m \cdot \alpha_1 \cdot L_s}{2 \cdot L_0}$$

$$P_{d_4} = P_4 - \frac{m \cdot \alpha_1 \cdot L_s}{2 \cdot L_0}$$

(3) Mean Load

$$P_{m_1} = \sqrt[3]{\frac{1}{L_s} (P_{a_1}^3 \cdot S_1 + P_1^3 \cdot S_2 + P_{d_1}^3 \cdot S_3)} \quad P_{m_3} = \sqrt[3]{\frac{1}{L_s} (P_{a_3}^3 \cdot S_1 + P_3^3 \cdot S_2 + P_{d_3}^3 \cdot S_3)}$$

$$P_{m_2} = \sqrt[3]{\frac{1}{L_s} (P_{a_2}^3 \cdot S_1 + P_2^3 \cdot S_2 + P_{d_2}^3 \cdot S_3)} \quad P_{m_4} = \sqrt[3]{\frac{1}{L_s} (P_{a_4}^3 \cdot S_1 + P_4^3 \cdot S_2 + P_{d_4}^3 \cdot S_3)}$$

※ Pan1 · Pdn represent loads exerted on the Linear Guide block. The suffix "n" indicates the block number in the diagram above.

Mean Load Calculation Example (II)

(1) Operating conditions-Installations on Rails.

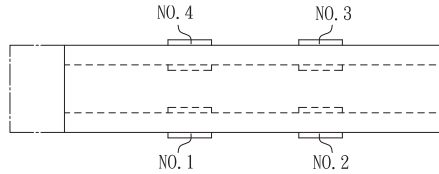

Fig 1.7.8

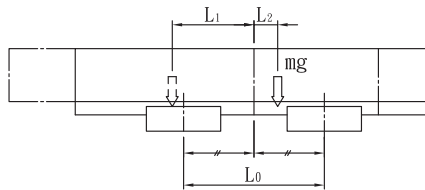

Fig 1.7.9

(2) Load applied to the Linear Guide block

1. At the left of the arm
2. At the right of the arm

$$P_{L1} = + \frac{mg}{4} + \frac{mg \cdot L_1}{2 \cdot L_0}$$

$$P_{r1} = + \frac{mg}{4} - \frac{mg \cdot L_1}{2 \cdot L_0}$$

$$P_{L2} = + \frac{mg}{4} - \frac{mg \cdot L_1}{2 \cdot L_0}$$

$$P_{r2} = + \frac{mg}{4} + \frac{mg \cdot L_1}{2 \cdot L_0}$$

$$P_{L3} = + \frac{mg}{4} - \frac{mg \cdot L_1}{2 \cdot L_0}$$

$$P_{r3} = + \frac{mg}{4} + \frac{mg \cdot L_1}{2 \cdot L_0}$$

$$P_{L4} = + \frac{mg}{4} + \frac{mg \cdot L_1}{2 \cdot L_0}$$

$$P_{r4} = + \frac{mg}{4} - \frac{mg \cdot L_1}{2 \cdot L_0}$$

(3) Mean load

$$P_{m1} = \frac{1}{3} (2 \cdot |P_{L1}| + |P_{r1}|)$$

$$P_{m1} = \frac{1}{3} (2 \cdot |P_{L2}| + |P_{r2}|)$$

$$P_{m1} = \frac{1}{3} (2 \cdot |P_{L3}| + |P_{r3}|)$$

$$P_{m1} = \frac{1}{3} (2 \cdot |P_{L4}| + |P_{r4}|)$$

※ P_{Ln} · P_{rn} represent loads exerted on the Linear Guide block. The suffix "n" indicates the block number in the diagram above.

ABOUT LINEAR GUIDE

1-8 Calculation Example

1-8-1 Calculation Examples (I)

(1) Operating conditions-Horizontal installations subjected to high acceleration and deceleration.

Model number : TRH30FE

Basic dynamic-load rating $C = 4791 \text{ kgf}$

Basic static-load rating $C_0 = 9004 \text{ kgf}$

Gravitational acceleration : $g = 9.8 \text{ (m/s}^2\text{)}$

Load : $m_1 = 600 \text{ kg}$

Load : $m_2 = 380 \text{ kg}$

Velocity : $V = 0.5 \text{ m/s}$

Time : $t_1 = 0.05 \text{ s}$

Time : $t_2 = 2.8 \text{ s}$

Time : $t_3 = 0.15 \text{ s}$

Acceleration : $a_1 = 10 \text{ m/s}^2$

Deceleration : $a_3 = 3.333 \text{ m/s}^2$

Stroke : $L_s = 1450 \text{ mm}$

Distance : $L_0 = 600 \text{ mm}$

$L_1 = 400 \text{ mm}$

$L_2 = 100 \text{ mm}$

$L_3 = 50 \text{ mm}$

$L_4 = 200 \text{ mm}$

$L_5 = 400 \text{ mm}$

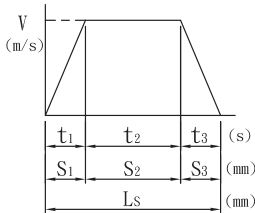

Fig 1.8.1

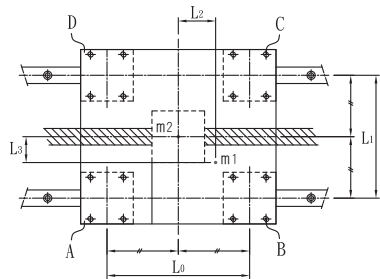

Fig 1.8.2

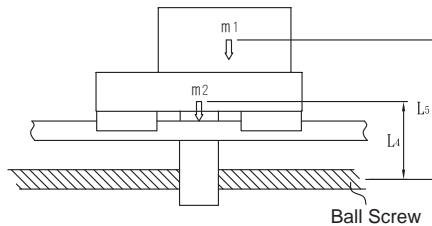

Fig 1.8.3

(2) Load Exerted on the Linear Guide by the Linear Guide Block

The calculations of blocks' load distribution under various circumstances.

1. In uniform motion Load applied in radial direction P_n (Base on the first condition of load exerted (please refer to page A15, No.1), taking m_1 and m_2 into consideration.

$$P_A = \frac{m_1}{4} - \frac{m_1 \cdot L_2}{2 \cdot L_0} + \frac{m_1 \cdot L_3}{2 \cdot L_1} + \frac{m_2}{4} = 232.5 \text{ kg} \quad P_C = \frac{m_1}{4} + \frac{m_1 \cdot L_2}{2 \cdot L_0} - \frac{m_1 \cdot L_3}{2 \cdot L_1} + \frac{m_2}{4} = 257.5 \text{ kg}$$

$$P_B = \frac{m_1}{4} + \frac{m_1 \cdot L_2}{2 \cdot L_0} + \frac{m_1 \cdot L_3}{2 \cdot L_1} + \frac{m_2}{4} = 332.5 \text{ kg} \quad P_D = \frac{m_1}{4} - \frac{m_1 \cdot L_2}{2 \cdot L_0} - \frac{m_1 \cdot L_3}{2 \cdot L_1} + \frac{m_2}{4} = 157.5 \text{ kg}$$

2. During acceleration to the left Load applied in radial direction P_{nL_a} and lateral direction P_{ntL_a} (Base on the 8th condition of load exerted (please refer to page A18, No.8). The load should allocate on the central of table, and $\frac{m_1}{4}$ should be re-placed (please refer to page A15, No.1) by P_n).

$$P_{AL_a} = P_A - \frac{m_1 \cdot a_1 \cdot L_5}{2 \cdot L_0 \cdot g} - \frac{m_2 \cdot a_1 \cdot L_4}{2 \cdot L_0 \cdot g} = -35.93 \text{ kg} \quad P_{CL_a} = P_C - \frac{m_1 \cdot a_1 \cdot L_5}{2 \cdot L_0 \cdot g} - \frac{m_2 \cdot a_1 \cdot L_4}{2 \cdot L_0 \cdot g} = -10.93 \text{ kg}$$

$$P_{BL_a} = P_B - \frac{m_1 \cdot a_1 \cdot L_5}{2 \cdot L_0 \cdot g} - \frac{m_2 \cdot a_1 \cdot L_4}{2 \cdot L_0 \cdot g} = 64.07 \text{ kg} \quad P_{DL_a} = P_D - \frac{m_1 \cdot a_1 \cdot L_5}{2 \cdot L_0 \cdot g} - \frac{m_2 \cdot a_1 \cdot L_4}{2 \cdot L_0 \cdot g} = -110.93 \text{ kg}$$

$$P_{A1L_a} = -\frac{m_1 \cdot a_1 \cdot L_3}{2 \cdot L_0 \cdot g} = -25.48 \text{ kg} \quad P_{C1L_a} = \frac{m_1 \cdot a_1 \cdot L_3}{2 \cdot L_0 \cdot g} = 25.48 \text{ kg}$$

$$P_{B1L_a} = \frac{m_1 \cdot a_1 \cdot L_3}{2 \cdot L_0 \cdot g} = 25.48 \text{ kg} \quad P_{D1L_a} = -\frac{m_1 \cdot a_1 \cdot L_3}{2 \cdot L_0 \cdot g} = -25.48 \text{ kg}$$

3. During deceleration to the left Load applied in radial direction P_{nL_d}

$$P_{AL_d} = P_A + \frac{m_1 \cdot a_3 \cdot L_5}{2 \cdot L_0 \cdot g} + \frac{m_2 \cdot a_3 \cdot L_4}{2 \cdot L_0 \cdot g} = 321.89 \text{ kg} \quad P_{CL_d} = P_C - \frac{m_1 \cdot a_3 \cdot L_5}{2 \cdot L_0 \cdot g} - \frac{m_2 \cdot a_3 \cdot L_4}{2 \cdot L_0 \cdot g} = 168.11 \text{ kg}$$

$$P_{BL_d} = P_B - \frac{m_1 \cdot a_3 \cdot L_5}{2 \cdot L_0 \cdot g} - \frac{m_2 \cdot a_3 \cdot L_4}{2 \cdot L_0 \cdot g} = 243.11 \text{ kg} \quad P_{DL_d} = P_D + \frac{m_1 \cdot a_3 \cdot L_5}{2 \cdot L_0 \cdot g} + \frac{m_2 \cdot a_3 \cdot L_4}{2 \cdot L_0 \cdot g} = 246.89 \text{ kg}$$

Load applied in lateral direction P_{ntL_d}

$$P_{A1L_d} = \frac{m_1 \cdot a_3 \cdot L_3}{2 \cdot L_0 \cdot g} = 8.5 \text{ kg} \quad P_{C1L_d} = -\frac{m_1 \cdot a_3 \cdot L_3}{2 \cdot L_0 \cdot g} = -8.5 \text{ kg}$$

$$P_{B1L_d} = -\frac{m_1 \cdot a_3 \cdot L_3}{2 \cdot L_0 \cdot g} = -8.5 \text{ kg} \quad P_{D1L_d} = \frac{m_1 \cdot a_3 \cdot L_3}{2 \cdot L_0 \cdot g} = 8.5 \text{ kg}$$

ABOUT LINEAR GUIDE

1-8 Calculation Example

4. During acceleration to the right Load applied in radial direction P_{nR_a}

$$P_{A R_a} = P_A + \frac{m_1 \cdot a_1 \cdot L_5}{2 \cdot L_0 \cdot g} + \frac{m_2 \cdot a_1 \cdot L_4}{2 \cdot L_0 \cdot g} = 500.93 \text{ kg} \quad P_{C R_a} = P_C - \frac{m_1 \cdot a_1 \cdot L_5}{2 \cdot L_0 \cdot g} - \frac{m_2 \cdot a_1 \cdot L_4}{2 \cdot L_0 \cdot g} = -10.93 \text{ kg}$$

$$P_{B R_a} = P_B - \frac{m_1 \cdot a_1 \cdot L_5}{2 \cdot L_0 \cdot g} - \frac{m_2 \cdot a_1 \cdot L_4}{2 \cdot L_0 \cdot g} = 64.07 \text{ kg} \quad P_{D R_a} = P_D + \frac{m_1 \cdot a_1 \cdot L_5}{2 \cdot L_0 \cdot g} + \frac{m_2 \cdot a_1 \cdot L_4}{2 \cdot L_0 \cdot g} = 425.93 \text{ kg}$$

Load applied in lateral direction P_{nL_d}

$$P_{A L_d} = \frac{m_1 \cdot a_1 \cdot L_3}{2 \cdot L_0 \cdot g} = 25.48 \text{ kg} \quad P_{C L_d} = -\frac{m_1 \cdot a_1 \cdot L_3}{2 \cdot L_0 \cdot g} = -25.48 \text{ kg}$$

$$P_{B L_d} = -\frac{m_1 \cdot a_1 \cdot L_3}{2 \cdot L_0 \cdot g} = -25.48 \text{ kg} \quad P_{D L_d} = \frac{m_1 \cdot a_1 \cdot L_3}{2 \cdot L_0 \cdot g} = 25.48 \text{ kg}$$

5. During deceleration to the right Load applied in radial direction P_{nR_d} and Load applied in lateral direction P_{nL_d}

$$P_{A R_d} = P_A - \frac{m_1 \cdot a_3 \cdot L_5}{2 \cdot L_0 \cdot g} - \frac{m_2 \cdot a_3 \cdot L_4}{2 \cdot L_0 \cdot g} = 143.11 \text{ kg}$$

$$P_{B R_d} = P_B + \frac{m_1 \cdot a_3 \cdot L_5}{2 \cdot L_0 \cdot g} + \frac{m_2 \cdot a_3 \cdot L_4}{2 \cdot L_0 \cdot g} = 421.89 \text{ kg}$$

$$P_{C R_d} = P_C + \frac{m_1 \cdot a_3 \cdot L_5}{2 \cdot L_0 \cdot g} + \frac{m_2 \cdot a_3 \cdot L_4}{2 \cdot L_0 \cdot g} = 346.89 \text{ kg}$$

$$P_{D R_d} = P_D - \frac{m_1 \cdot a_3 \cdot L_5}{2 \cdot L_0 \cdot g} - \frac{m_2 \cdot a_3 \cdot L_4}{2 \cdot L_0 \cdot g} = 68.11 \text{ kg}$$

Load applied in lateral direction P_{nL_d}

$$P_{A L_d} = -\frac{m_1 \cdot a_3 \cdot L_3}{2 \cdot L_0 \cdot g} = -8.5 \text{ kg} \quad P_{C L_d} = \frac{m_1 \cdot a_3 \cdot L_3}{2 \cdot L_0 \cdot g} = 8.5 \text{ kg}$$

$$P_{B L_d} = \frac{m_1 \cdot a_3 \cdot L_3}{2 \cdot L_0 \cdot g} = 8.5 \text{ kg} \quad P_{D L_d} = -\frac{m_1 \cdot a_3 \cdot L_3}{2 \cdot L_0 \cdot g} = -8.5 \text{ kg}$$

(3) Combined radial and thrust load P_{En} 1. In uniform motion P_{En}

$$P_{EA} = P_A = 232.5 \text{ kg}$$

$$P_{EB} = P_B = 332.5 \text{ kg}$$

$$P_{EC} = P_C = 257.5 \text{ kg}$$

$$P_{ED} = P_D = 157.5 \text{ kg}$$

2. During acceleration to the left P_{EnL_a}

$$P_{EAL_a} = |P_{AL_a}| + |P_{AtL_a}| = 61.41 \text{ kg}$$

$$P_{EBL_a} = |P_{BL_a}| + |P_{BtL_a}| = 89.55 \text{ kg}$$

$$P_{ECL_a} = |P_{CL_a}| + |P_{CtL_a}| = 36.41 \text{ kg}$$

$$P_{EDL_a} = |P_{DL_a}| + |P_{DtL_a}| = 136.41 \text{ kg}$$

3. During deceleration to the left P_{EnL_d}

$$P_{EAL_d} = |P_{AL_d}| + |P_{AtL_d}| = 330.39 \text{ kg}$$

$$P_{EBL_d} = |P_{BL_d}| + |P_{BtL_d}| = 251.61 \text{ kg}$$

$$P_{ECL_d} = |P_{CL_d}| + |P_{CtL_d}| = 176.61 \text{ kg}$$

$$P_{EDL_d} = |P_{DL_d}| + |P_{DtL_d}| = 255.39 \text{ kg}$$

4. During acceleration to the right P_{EnR_a}

$$P_{EAR_a} = |P_{AR_a}| + |P_{AtR_a}| = 509.43 \text{ kg}$$

$$P_{EBR_a} = |P_{BR_a}| + |P_{BtR_a}| = 72.57 \text{ kg}$$

$$P_{ECR_a} = |P_{CR_a}| + |P_{CtR_a}| = 19.43 \text{ kg}$$

$$P_{EDR_a} = |P_{DR_a}| + |P_{DtR_a}| = 434.43 \text{ kg}$$

5. During deceleration to the right P_{EnR_d}

$$P_{EAR_d} = |P_{AR_d}| + |P_{AtR_d}| = 151.61 \text{ kg}$$

$$P_{EBR_d} = |P_{BR_d}| + |P_{BtR_d}| = 430.39 \text{ kg}$$

$$P_{ECR_d} = |P_{CR_d}| + |P_{CtR_d}| = 355.39 \text{ kg}$$

$$P_{EDR_d} = |P_{DR_d}| + |P_{DtR_d}| = 76.61 \text{ kg}$$

(4) Static Safety Factor

As shown above, it is during acceleration of the B Linear Guide to the left when the maximum load is exerted on the Linear Guide. Therefore, the static safety factor (f_s) becomes as follows :

$$f_s = \frac{C_0}{509.43} = \frac{9004}{509.43} = 17.67$$

ABOUT LINEAR GUIDE

1-8 Calculation Example

(5) Mean Load P_{mn}

For each block, load is different under uniform speed, acceleration and deceleration circumstances. To acquire service life, mean load must be calculated by acquiring the travel distance of each block during uniform speed, acceleration and deceleration in advance.

$$S_1 = \frac{1}{2} t_1 V = \frac{1}{2} (0.05)(0.5)m = 0.0125m = 12.5 \text{ mm} \quad S_3 = \frac{1}{2} t_3 V = (0.15)(0.5)m = 0.0375m = 37.5 \text{ mm}$$

$$S_2 = t_2 V = (2.8)(0.5)m = 1.4m = 1400 \text{ mm} \quad \text{Nominal Life } L_S = S_1 + S_2 + S_3 = 1450 \text{ mm}$$

The mean load on each LM block is as follows :

$$P_{mA} = \sqrt[3]{\frac{1}{2 \cdot L_S} (P_{EA}^3 \cdot a \cdot S_1 + P_{EA}^3 \cdot S_2 + P_{EA}^3 \cdot d \cdot S_3 + P_{EA}^3 \cdot R_a \cdot S_1 + P_{EA}^3 \cdot S_2 + P_{EA}^3 \cdot R_d \cdot S_3)} = 236.43 \text{ kg}$$

$$P_{mB} = \sqrt[3]{\frac{1}{2 \cdot L_S} (P_{EB}^3 \cdot a \cdot S_1 + P_{EB}^3 \cdot S_2 + P_{EB}^3 \cdot d \cdot S_3 + P_{EB}^3 \cdot R_a \cdot S_1 + P_{EB}^3 \cdot S_2 + P_{EB}^3 \cdot R_d \cdot S_3)} = 332.42 \text{ kg}$$

$$P_{mC} = \sqrt[3]{\frac{1}{2 \cdot L_S} (P_{EC}^3 \cdot a \cdot S_1 + P_{EC}^3 \cdot S_2 + P_{EC}^3 \cdot d \cdot S_3 + P_{EC}^3 \cdot R_a \cdot S_1 + P_{EC}^3 \cdot S_2 + P_{EC}^3 \cdot R_d \cdot S_3)} = 257.82 \text{ kg}$$

$$P_{mD} = \sqrt[3]{\frac{1}{2 \cdot L_S} (P_{ED}^3 \cdot a \cdot S_1 + P_{ED}^3 \cdot S_2 + P_{ED}^3 \cdot d \cdot S_3 + P_{ED}^3 \cdot R_a \cdot S_1 + P_{ED}^3 \cdot S_2 + P_{ED}^3 \cdot R_d \cdot S_3)} = 163.33 \text{ kg}$$

(6) Nominal life L_n (Assume $f_w = 1.5$)

$$(L_A = \frac{C}{f_w \cdot P_{mA}})^3 \cdot 50 = 123265.9 \text{ km} \quad (L_C = \frac{C}{f_w \cdot P_{mC}})^3 \cdot 50 = 95069.19 \text{ km}$$

$$(L_B = \frac{C}{f_w \cdot P_{mB}})^3 \cdot 50 = 44351.32 \text{ km} \quad (L_D = \frac{C}{f_w \cdot P_{mD}})^3 \cdot 50 = 373897.7 \text{ km}$$

※ From these calculations, 44351.32 km (the running distance of Linear Guide No.8) is obtained as the service life of the Linear Guide used in a machine or system under the operating conditions specified above.

In the example above, we assume that we have two loads (W_1 and W_2). If there is only one load W_1 , simply take W_2 as zero. The appropriate formula determined by condition of loading.

Example (II)

(1) Operation Conditions-Vertical Installations Table (L type) has combined blocks weight w_1 and w_2 . Furthermore, the mass w_0 is applied during uniform ascent by Distance 1000mm. After the mass is dropped, empty table is removed during uniform descent. The table has total four Linear Guide blocks.

Model number : TRH30FE

(dynamic-load rating : $C = 4791$ kgf)

(static-load rating : $C_0 = 9004$ kgf)

Gravitational Acceleration : $g = 9.8$ (m/s^2)

Mass : $m_0 = 200$ kg

Weight of Table1 : $m_1 = 400$ kg

Weight of Table2 : $m_2 = 200$ kg

$L_0 = 300$ mm

$L_1 = 80$ mm

$L_2 = 50$ mm

$L_3 = 280$ mm

$L_4 = 150$ mm

$L_5 = 250$ mm

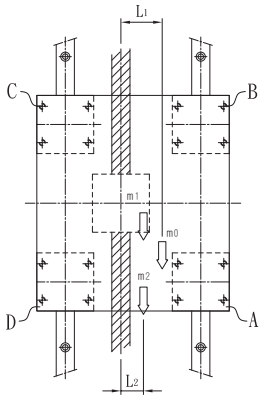

The mass is applied during ascent only.
It is removed during descent.

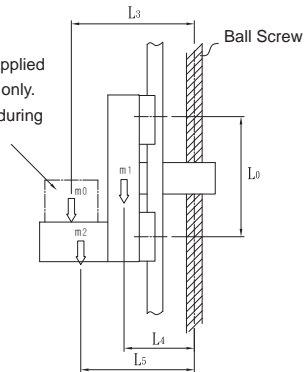

Fig 1.8.4

ABOUT LINEAR GUIDE

1-8 Calculation Example

(2) Calculation of blocks load distribution under various circumstances.

When the Linear Guide move vertically, take M_0 , M_1 and M_2 into consideration individually by using the third condition shown in 1.5.1 【please refer to A16. No.3】

1. The radial load(P_m) of blocks while ascending with load M_0 .

$$P_{AU} = \frac{m_1 \cdot L_4}{2 \cdot L_0} + \frac{m_2 \cdot L_5}{2 \cdot L_0} + \frac{m_0 \cdot L_3}{2 \cdot L_0} = 276.7 \text{ kg} \quad P_{CU} = -\frac{m_1 \cdot L_4}{2 \cdot L_0} - \frac{m_2 \cdot L_5}{2 \cdot L_0} - \frac{m_0 \cdot L_3}{2 \cdot L_0} = -276.7 \text{ kg}$$

$$P_{BU} = -\frac{m_1 \cdot L_4}{2 \cdot L_0} - \frac{m_2 \cdot L_5}{2 \cdot L_0} - \frac{m_0 \cdot L_3}{2 \cdot L_0} = -276.7 \text{ kg} \quad P_{DU} = \frac{m_1 \cdot L_4}{2 \cdot L_0} + \frac{m_2 \cdot L_5}{2 \cdot L_0} + \frac{m_0 \cdot L_3}{2 \cdot L_0} = 276.7 \text{ kg}$$

Lateral load $P_n T_u$ of blocks while ascending.

$$P_{ATU} = \frac{m_1 \cdot L_2}{2 \cdot L_0} + \frac{m_2 \cdot L_2}{2 \cdot L_0} + \frac{m_0 \cdot L_1}{2 \cdot L_0} = 76.7 \text{ kg} \quad P_{CTU} = -\frac{m_1 \cdot L_2}{2 \cdot L_0} - \frac{m_2 \cdot L_2}{2 \cdot L_0} - \frac{m_0 \cdot L_1}{2 \cdot L_0} = -76.7 \text{ kg}$$

$$P_{BTU} = -\frac{m_1 \cdot L_2}{2 \cdot L_0} - \frac{m_2 \cdot L_2}{2 \cdot L_0} - \frac{m_0 \cdot L_1}{2 \cdot L_0} = -76.7 \text{ kg} \quad P_{DTU} = \frac{m_1 \cdot L_2}{2 \cdot L_0} + \frac{m_2 \cdot L_2}{2 \cdot L_0} + \frac{m_0 \cdot L_1}{2 \cdot L_0} = 76.7 \text{ kg}$$

2. Radial load of each block while descending with no load.

$$P_{AD} = \frac{m_1 \cdot L_4}{2 \cdot L_0} + \frac{m_2 \cdot L_5}{2 \cdot L_0} = 183.3 \text{ kg} \quad P_{CD} = -\frac{m_1 \cdot L_4}{2 \cdot L_0} - \frac{m_2 \cdot L_5}{2 \cdot L_0} = -183.3 \text{ kg}$$

$$P_{BD} = -\frac{m_1 \cdot L_4}{2 \cdot L_0} - \frac{m_2 \cdot L_5}{2 \cdot L_0} = -183.3 \text{ kg} \quad P_{DD} = \frac{m_1 \cdot L_4}{2 \cdot L_0} + \frac{m_2 \cdot L_5}{2 \cdot L_0} = 183.3 \text{ kg}$$

Lateral load of block while descending.

$$P_{ATD} = \frac{m_2 \cdot L_2}{2 \cdot L_0} + \frac{m_0 \cdot L_2}{2 \cdot L_0} = 33.3 \text{ kg} \quad P_{CTD} = -\frac{m_2 \cdot L_2}{2 \cdot L_0} - \frac{m_0 \cdot L_2}{2 \cdot L_0} = -33.3 \text{ kg}$$

$$P_{BD} = -\frac{m_2 \cdot L_2}{2 \cdot L_0} - \frac{m_0 \cdot L_2}{2 \cdot L_0} = -33.3 \text{ kg} \quad P_{DTD} = \frac{m_2 \cdot L_2}{2 \cdot L_0} + \frac{m_0 \cdot L_2}{2 \cdot L_0} = 33.3 \text{ kg}$$

(3) Combined radial and thrust load P_{En}

1. During ascent

$$P_{EAU} = |P_{AU}| + |P_{ATU}| = 353.4 \text{ kg}$$

$$P_{EBU} = |P_{BU}| + |P_{BTU}| = 353.4 \text{ kg}$$

$$P_{ECU} = |P_{CU}| + |P_{CTU}| = 353.4 \text{ kg}$$

$$P_{EDU} = |P_{DU}| + |P_{DTU}| = 353.4 \text{ kg}$$

$$P_{EAD} = |P_{AD}| + |P_{ATD}| = 216.6 \text{ kg}$$

$$P_{EBD} = |P_{BD}| + |P_{BTD}| = 216.6 \text{ kg}$$

$$P_{ECD} = |P_{CD}| + |P_{CTD}| = 216.6 \text{ kg}$$

$$P_{EDD} = |P_{DD}| + |P_{DTD}| = 216.6 \text{ kg}$$

(4) Static Safety Factor

The static safety factor (f_s) of a machine or system under the operating conditions shown above becomes the following :

$$f_s = \frac{C_0}{353.4\text{kg}} = \frac{9004}{353.4} = 25.48$$

(5) Mean Load P_{mn}

$$P_{mA} = \sqrt[3]{\frac{1}{2 \ell_S} (P_{EAU}^3 \cdot \ell_S + P_{EAD}^3 \cdot \ell_S)} = 300.6 \text{ kg} \quad P_{mC} = \sqrt[3]{\frac{1}{2 \ell_S} (P_{ECU}^3 \cdot \ell_S + P_{ECD}^3 \cdot \ell_S)} = 300.6 \text{ kg}$$

$$P_{mB} = \sqrt[3]{\frac{1}{2 \ell_S} (P_{EBU}^3 \cdot \ell_S + P_{EBD}^3 \cdot \ell_S)} = 300.6 \text{ kg} \quad P_{mD} = \sqrt[3]{\frac{1}{2 \ell_S} (P_{EDU}^3 \cdot \ell_S + P_{EDD}^3 \cdot \ell_S)} = 300.6 \text{ kg}$$

(6) Nominal life L_n (Assume $f_w = 1.2$)

$$L_A = \left(\frac{C}{f_w \cdot P_{mA}} \right)^3 \cdot 50\text{km} = 117148.8 \text{ km}$$

$$L_C = \left(\frac{C}{f_w \cdot P_{mC}} \right)^3 \cdot 50\text{km} = 117148.8 \text{ km}$$

$$L_B = \left(\frac{C}{f_w \cdot P_{mB}} \right)^3 \cdot 50 \text{ km} = 117148.8 \text{ km}$$

$$L_D = \left(\frac{C}{f_w \cdot P_{mD}} \right)^3 \cdot 50\text{km} = 117148.8 \text{ km}$$

ABOUT LINEAR GUIDE

1-9 Accuracy

■ 1-9-1 Accuracy Standards

The accuracy of rail is determined by the tolerance of its parallelism, height and width, if there is multiple blocks on a rail or multiple Linear Guide on a surface, the difference of height and width between each block and Linear Guide are standardized and shown in the catalogue.

Running Parallelism

Mount a Linear Guide on a datum surface and measure the parallelism difference of block while operating its full travel distance.

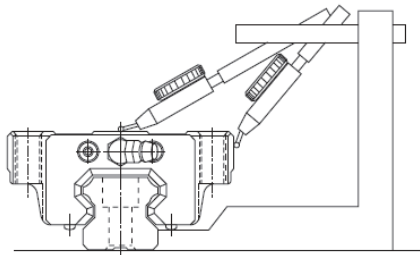

Fig 1.9.1 Running Parallelism

Difference in Height M among Linear Guide Blocks

On the same datum surface, the difference between maximum and minimum height of each block.

Difference in Rail-to-Block Lateral Distance W_2 among Linear Guide Blocks

On the same rail, the difference between maximum and minimum width of each block.

※ Note.1

With two or more sets of Linear Guide installed in parallel on the same plane, the tolerance for the rail-to-block lateral distance (W_2) and the differences therein among Linear Guide blocks apply to the master – rail side only.

※ Note.2

Accuracy measurements indicate mean values of measurements taken at the center or central area of each Linear Guide block.

※ Note.3

Linear Guide rails are smoothly curved so that when they are installed on a machine they are easily straightened, and pressing them onto the machine reference base enables the design accuracy to be achieved. If installed on a base lacking rigidity, such as an aluminum base, the bend of LinearGuide rails may affect machine precision. In such a case, the straightness should be set in advance.

1-9-2 Averaging Effect

The Linear Guide incorporates precision balls with high circularity, enabling a constrained structure with no clearance. Moreover, in a multiple-axis configuration with the axis arranged in parallel to one another, the component Linear Guides therein combine to form an entire constrained guideway.

The effect of equalization is different, due to the error of length, size, preload of rail, axis constrained structure and etc, as the table shown below; adding one rail a straightness error and its actual operating accuracy is shown in the diagram below. Through the feature of equalization, a high operating accuracy structure can be provided.

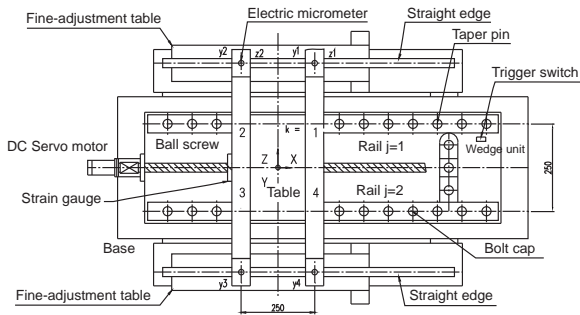

Fig 1.9.2

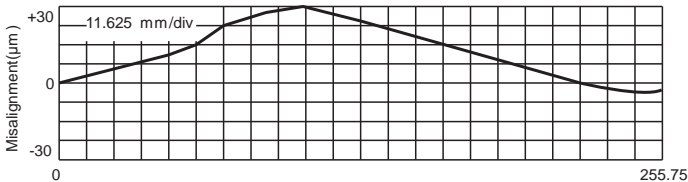

Fig 1.9.3 Misalignment profile

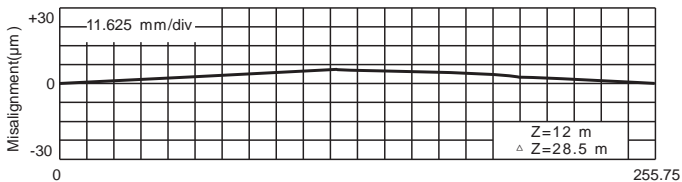

Fig 1.9.4 Horizontal displacement of the table

ABOUT LINEAR GUIDE

1-10 Predicting the Rigidity

■ 1-10-1 Determining Radial Clearance and the Magnitude of a Preload Radial Clearance

The radial clearance of the Linear Guide is the displacement of Linear Guide block caused by the vertical plane when the block is lightly pushed forward or backward at the longitudinal center of the Linear Guide rail secured in place.

The radial clearance is divided into ZF (Slight Clearance), Z0 (No Preload), Clearance Z1 (light preload), Z2 (medium preload) and Z3 (heavy preload). The most appropriate clearance can be selected in accordance with the intended applications. The radial clearances and preload values are standardized for each type of Linear Guide.

The radial clearance of the Linear Guide significantly affects its running precision, load-withstanding performance, and rigidity. It is therefore particularly important to select the correct clearance for your purpose. In general, a negative clearance has a favorable effect on service life and precision, if the Linear Guide is subjected to significant vibration and impact due to reciprocal motion.

Preload

The preload is an internal load exerted on rolling elements in the Linear Guide block, for the purpose of increasing the block rigidity and reducing clearance. Clearance symbol for the Linear Guide, ZF, Z0, Z1, Z2 and Z3 represent negative clearance resulting from a preload and are expressed in negative values. All Linear Guide models (excluding the separate type) are shipped with their clearance adjusted to user specifications. Therefore, it is not necessary for users to adjust the preload themselves. We will select the clearance suited to your operating conditions. Please contact us.

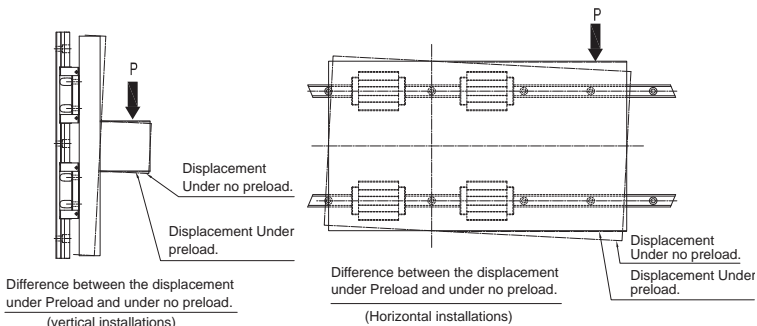

Fig 1.10.1 Relationship Between Preload and Displacement

Table 1.10.1

	Preload		
	ZF~Z0 Slight Clearance, Zero Preload.	Z1 Zero Clearance, Light Preload.	Z2 Zero Clearance, Medium preload.
OperatingConditions	The loading direction is fixed; impact and vibration are slight; two axes are installed in parallel. High precision is not required and the sliding resistance must be low.	The location is under an overhang and a moment load. The Linear Guide is used in a one-axis configuration. The location with light load and high precision requirement.	The location requires light rigidity and is subjected to vibration and impact. The application is a heavy-cutting machine tool or the like.
SampleApplications	<ul style="list-style-type: none"> ◆ Beam-welding machine. ◆ Book-binding machine. ◆ Automatic packing machine. ◆ General-industrial-machine ◆ X-axis and Y-axis. ◆ Automatic sash-bar finishing machine. ◆ Welding machine. ◆ Circuit breaker. ◆ Tool changer. ◆ Various kinds of maternal feeder. 	<ul style="list-style-type: none"> ◆ Grinding-machine table feed shaft. ◆ Automatic painting machine. ◆ Industrial robot. ◆ Various kinds of high-speed material feeder. ◆ NC drilling machine. ◆ General-industrial-machine ◆ Z-axis. ◆ Printed-circuit-board drilling machine. ◆ Electric discharge machine. ◆ Measuring instrument. ◆ Precision XY table. 	<ul style="list-style-type: none"> ◆ Machining center. ◆ NC lathe. ◆ Grinding-machine grinding-wheel feed shaft. ◆ Milling machine. ◆ Vertical-and horizontal-boring machines. ◆ Tool rest guide. ◆ Machine-tool Z-axis.

Applied Load and Service Life Considering

When the Linear Guide is used under a preload (medium), the Linear Guide block receives an internal load. Therefore, the service life should be calculated in consideration of the preload. For preload considerations, please contact us, specifying the model numbers you have selected.

■ 1-10-2 Rigidity

When the Linear Guide receives a load, the steel balls, Linear Guide blocks, and rails undergo elastic deformation within a permissible range. The ratio of deformation to the load is the rigidity value. The rigidity of the Linear Guide increases as the preload increases. The Fig below shows the differences among the ordinary clearance Z1 and clearance Z2, Z3. As shown, in the case of the four-way equal-load type, the effect of preloading remains valid until the load increases to some 2.8 times the preload applied.

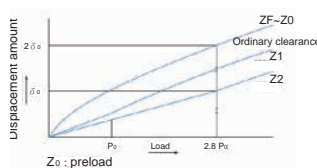

Fig 1.10.2 Rigidity Data

$$\delta = \frac{P}{K} \mu\text{m}$$

δ : Displacement

P : Load

K : Rigidity Value

ABOUT LINEAR GUIDE

1-11 Installation of Linear Guide

■ 1-11-1 Datum Representation

Jointed rail should be installed by following the arrow sign and ordinal number which is marked on the surface of each rail (see Fig 1.11.1) :

Marks

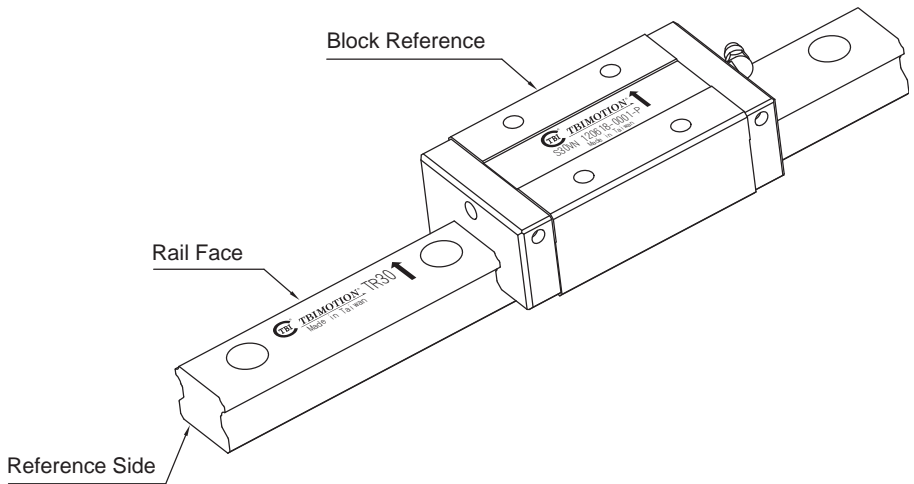
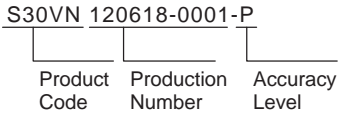

Fig 1.11.1 Datum Representation

■ 1-11-2 Recognizing of Master Rail

Linear rails to be applied on the same plane are all marked with the same serial number, and "M" is marked at the end of serial number for indicating the master rail, shown as the figure below. The reference side of carriage is the surface where is ground to a specified accuracy. For normal grade (N), it has no mark "M" on rail which means any one of rails with same serial number could be the master rail.

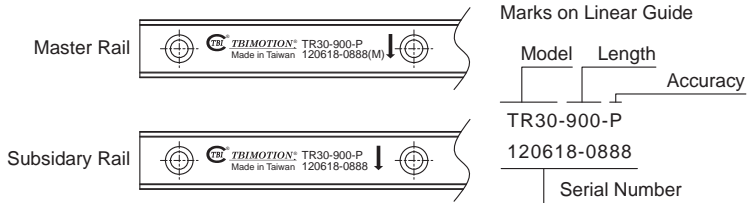

Fig 1.11.2 Recognizing of Master Rail

Combined Use of Rail and Carriage

For combined use, the rail and carriage must have the same serial number. When reinstalling the carriage back to the rail, make sure they have the same serial number and the reference side of carriage should be in accordance with that of rail.

ABOUT LINEAR GUIDE

1-11 Installation of Linear Guide

■ 1-11-3 For Butt-joint Rail

Accuracy may deviate at joints when carriages pass the joint simultaneously. Therefore, the joints should be interlaced for avoiding such accuracy problem.

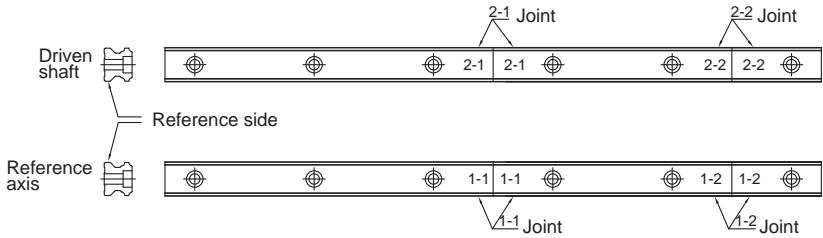

Fig 1.11.3 Butt-joint

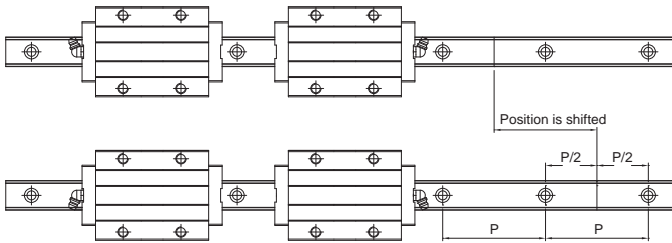
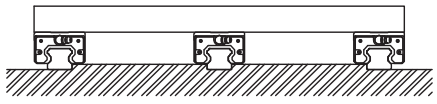
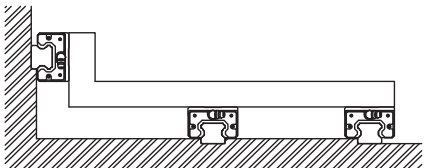
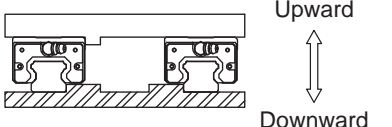
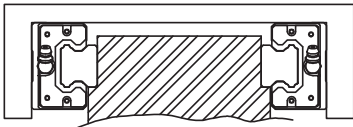
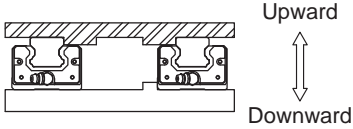
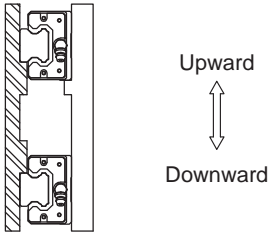
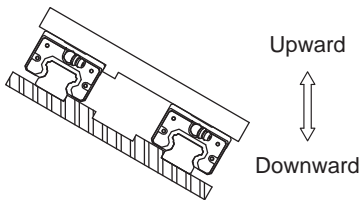
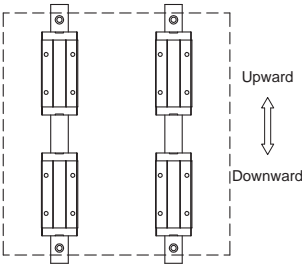

Fig 1.11.4

■ 1-11-4 Mounting Methods

Linear rail is designed to absorb the load of four dimensions; therefore, it can be mounted according to the load and structure of the equipment.

Table 1.11.1

<p>(A) Three-Axis Configuration.</p> 	<p>(B) Three-Axis Configuration.</p> 
<p>Horizontal Configuration.</p>	<p>Two-Axis External Configuration.</p>
 <p>Upward Downward</p>	
<p>Upside down Configuration.</p>	<p>Vertical Configuration.</p>
 <p>Upward Downward</p>	 <p>Upward Downward</p>
<p>Tilted Configuration.</p>	<p>Install on the wall.</p>
 <p>Upward Downward</p>	 <p>Upward Downward</p>

ABOUT LINEAR GUIDE

1-11 Installation of Linear Guide

■ 1-11-5 Common Fastening Method of Linear Guide

Table 1.11.2

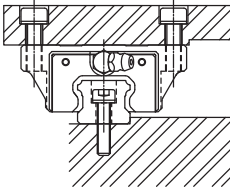
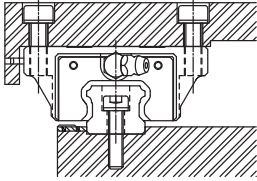
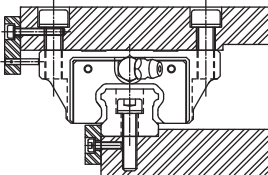
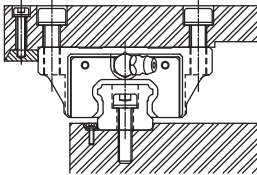
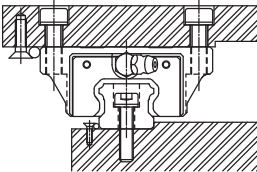
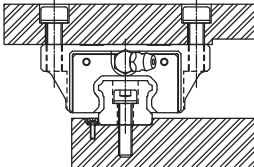
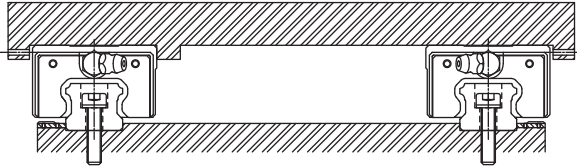
Fastened by pressing both Linear Guide blocks and rail against their respective reference surfaces.	Fastened by using push screws.
	
Fastened by using a hold-down plate.	Fastened by using a tapered gib.1
	
Fastened by using screws.	Fastened by using a tapered gib.2
	
A Setting Where the Host Machine is Subjected to Impact and Vibration.	
	

■ 1-11-6 Mounting the Linear Guide

Mounting Procedures

※ Sample Installation of the Linear Guide on a Vibration-and-Impact Susceptible Machine that Requires Rigidity and High Precision.

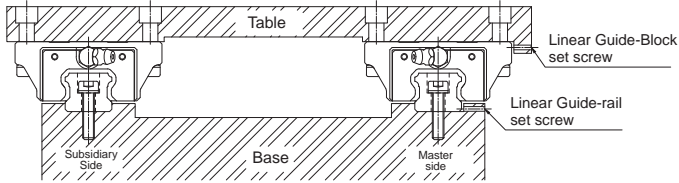

Fig 1.11.5 Mounting the Linear Guide on a Machine Susceptible to Vibration and Impact

Mounting the Linear Guide Rail

(A) Prior to assembly, always remove all burrs, dents and dust that are likely to form on the mounting surface of the machine on which Linear Guide is to be installed. (Fig 1.11.6)

CAUTION : The Linear Guide is delivered with an anticorrosive oil applied. Prior to assembly, be sure to remove the oil from the reference surface using a wash oil. If the anticorrosive oil is removed, the surface is likely to rust. The application of a low-viscosity spindle oil or the like is therefore recommended.

(B) Gently place a Linear Guide rail on the base, and temporarily tighten the bolts so that the rail lightly contacts the mounting surface. Hold the line marked side of the Linear Guide rail against matching the base-side reference surface (Fig 1.11.7)

CAUTION : Use clean bolts to fasten the Linear Guide. When inserting bolts into the Linear Guide rail mounting holes, make sure the threads of the bolt and nut are properly aligned. (Fig 1.11.8)

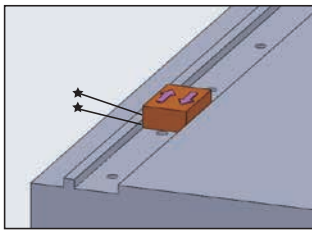

Fig 1.11.6 Checking the Mounting Surface.

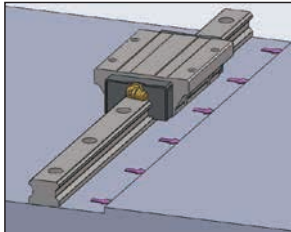

Fig 1.11.7 Holding an Linear Guide rail against the Reference Surface

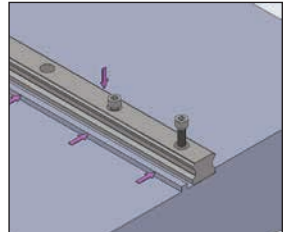

Fig 1.11.8 Checking Bolt Play

ABOUT LINEAR GUIDE

1-11 Installation of Linear Guide

Table 1.11.3 Tightening Torque for Allen Bolt

Unit : N-cm

ModelNo.	Tightening Torque		
	Iron	Casting	Aluminum
M2	57	39.2	29.4
M2.3	78.4	53.9	39.2
M2.6	118	78.4	58.8
M3	186	127	98.0
M4	392	274	206
M5	882	588	441
M6	1370	921	686
M8	3040	2010	1470
M10	6760	4510	3330
M12	11800	7840	5880
M14	15700	10500	7840
M16	19600	13100	9800
M20	38200	25500	19100
M22	51900	34800	26000
M24	65700	44100	32800
M30	130000	87200	65200

(C) Tighten the Linear Guide rail set screws in sequence, until they lightly contact the rail-mounting side surface.(Fig 1.11.9)

(D) Using a torque wrench, tightening the mounting bolts to the specific torque.(fig 1.11.10)

CAUTION : The sequence for tightening the Linear Guide rail mounting bolts should start from the center to the end. Following this sequence to maintain accuracy.

(E) Following the same procedures for the remaining Linear Guide rails, complete Linear Guide rail installation.

(F) Drive caps into the bolt holes on the Linear Guide rails so that they are flush with the rail top surface.

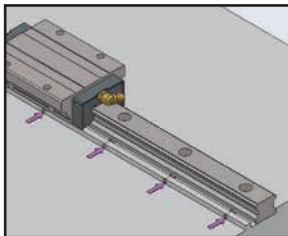

Fig 1.11.9 Tightening Set Screws

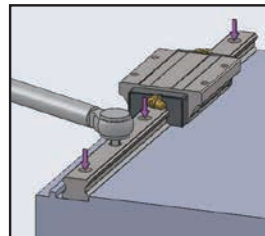

Fig 1.11.10 Full Tightening of Mounting Bolts

Mounting the Linear Guide Block

(A) Gently place a table on the Linear Guide blocks and temporarily tighten the mounting bolts.

(B) Using set screws, hold the master-rail Linear Guide block against the table reference-side surface, and position the table.

(C) Fully tighten the mounting bolts on both the master and subsidiary sides. This completes Linear Guide block installation.

CAUTION : To ensure uniform fastening of the table, tighten the mounting bolts diagonally, as shown in (Fig 1.11.11) in accordance with the numbers.

(D) Using a torque wrench, tightening the mounting bolts to the specified torque.(fig 1.11.10)

CAUTION : The sequence for tightening the Linear Guide rail mounting bolts should start from the center to the end. Following this sequence to maintain.

The method specified above minimizes the time required to ensure the straightness of the Linear Guide-rail. Moreover, there is no need to use the fastening knock pins, thereby greatly reducing the required assembly man-hours.

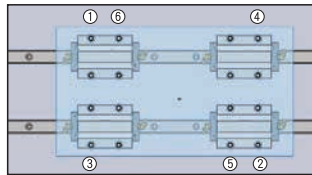

Fig 1.11.11

※ Sample Installation of the Linear Guide without Set Screws on the Master Linear Guide Rail.

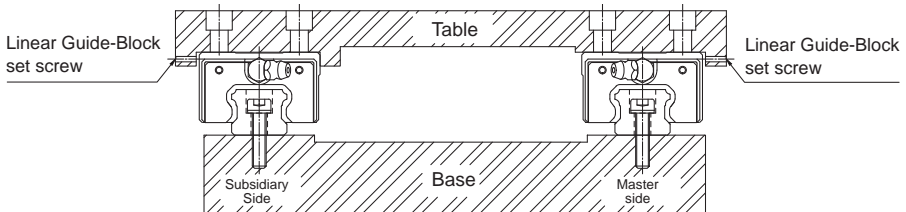

Fig 1.11.12 Mounting the Linear Guide without Set Screws on the Master Linear Guide Rail

ABOUT LINEAR GUIDE

1-11 Installation of Linear Guide

Mounting the Master Linear Guide Rail

After temporarily tightening the mounting bolts, use a small device or the like to firmly press the rail to the side, against the reference section. Fully tighten the mounting bolts. Repeat this for each mounting bolt in sequence. (Fig 1.11.13)

Mounting the Subsidiary Linear Guide Rail

To ensure parallelism of the subsidiary Linear Guide rail with the master Linear Guide rail properly mounted, the following methods are recommended.

Use a Straight Edge

Position a straight edge between the two rails then confirm parallelism with a dial gauge. Using the straight edge as a reference to confirm subsidiary rail straightness from one end to the other, tightening the mounting bolts in sequence as you go. (Fig 1.11.14)

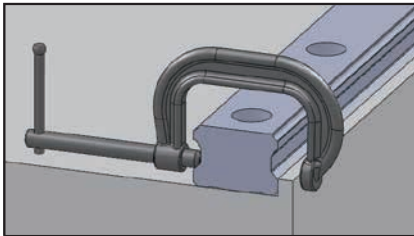

Fig 1.11.13 Mounting the master Linear Guide rail

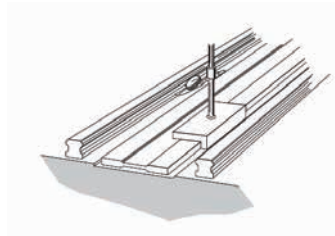

Fig 1.11.14 Use a straight edge

Move the Table

Fasten two Linear Guide blocks on the master side to the table (or a temporary measurement table). Temporarily fasten the subsidiary Linear Guide rail and block to the base and table. From the dial-gauge stand, with a dial gauge contact the subsidiary rail Linear Guide block side, move the table from the rail end and check the parallelism between the block and the subsidiary Linear Guide rail, fastening the bolts on sequences as you go. (Fig 1.11.15)

Compare to the Master Linear Guide Rail

Make sure the master Linear Guide rail is properly installed. Temporarily fasten the subsidiary Linear Guide rail in place. Place a table on the Linear Guide blocks mounted on the master rail and on the temporarily fastened subsidiary Linear Guide rail. Fully tighten the mounting bolts on the two Linear Guide blocks on the subsidiary rail. With the remaining Linear Guide block on the subsidiary rail temporarily fastened, correct the position of the subsidiary Linear Guide rail, fully tightening its mounting bolts in sequence as you go. (Fig 1.11.16)

Method Using a Jig

Using a jig as shown in (Fig 1.11.17) confirm parallelism between the master-rail-side reference surface and that of the subsidiary rail at each mounting hole, and fully tighten the mounting bolt there.

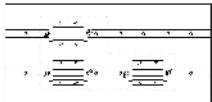

Fig 1.11.15 Move the table

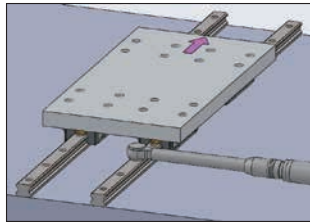

Fig 1.11.16 Compare to the master Linear Guide rail

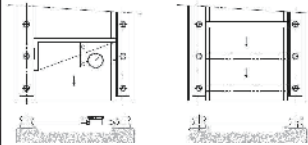

Fig 1.11.17

※ Sample Installation of the Linear Guide without a Reference Section for the Master Linear Guide Rail.

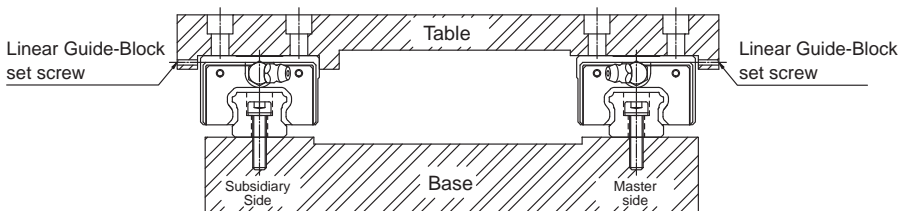

Fig 1.11.18 Installation of the Linear Guide without a Reference Section for the Master Linear Guide Rail

ABOUT LINEAR GUIDE

1-11 Installation of Linear Guide

Mounting the Master Linear Guide Rail

Use a Temporary Reference Surface from end to end to acquire Linear Guide rail straightness. For this method, however, two Linear Guide block must be fastened together, positioned on the top of each other while attached to a measurement plate, as shown in (Fig1.11.19).

Use a Straight Edge

After temporarily tightening the mounting bolts, use a dial gauge to check the straightness of the Linear Guide-rail-side reference surface from end to end, fully tightening the mounting bolts in sequence as you go, as shown in (Fig 1.11.20).

To mount the subsidiary Linear Guide rail, follow the procedures specified in the second paragraph on the previous page.

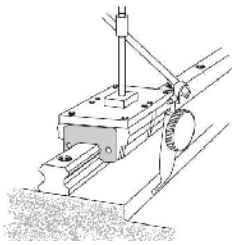

Fig 1.11.19 Use a Temporary Reference Surface

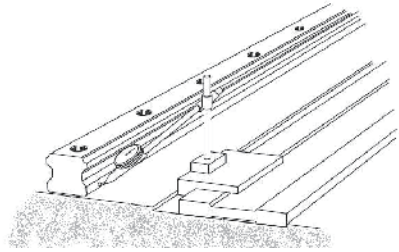

Fig 1.11.20 Use a Straight Edge

Shoulder Heights and Chamfers

Improper shoulder heights and chamfers of mounting surfaces will cause deviations in accuracy and rail or block interference with the chamfered part. When recommended shoulder heights and chamfers are used, problems with installation accuracy should be eliminated.

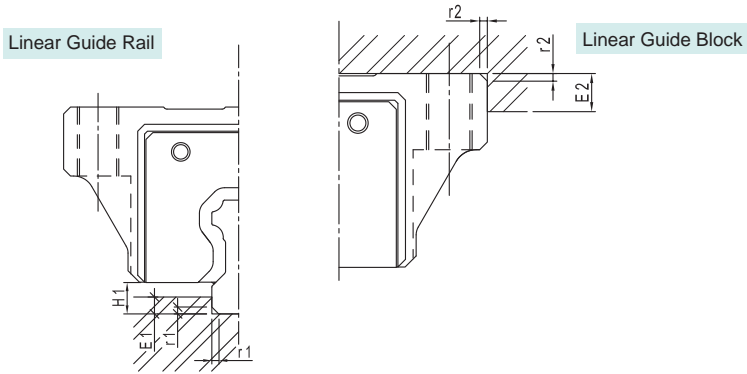

Fig 1.11.21

Table 1.11.4 Shoulder Height and Chamfer

Model No.	Max.chamfer of the rail r_1	Max.chamfer of the block r_2	Max.chamfer of the rail E_1	Max.chamfer of the rail E_2	Max.chamfer of the block H_1
TR15	0.5	0.5	3	4	3.2
TR20	0.5	0.5	3.5	5	4.6
TR25	1.0	0.9	5	5	5.8
TR30	1.0	1	5	5	7
TR35	1.0	1	6	6	7.5
TR45	1.0	1	8	8	8.9
TR55	1.5	1.5	10	10	13
TR65	1.5	1.5	8	10	14.3

ABOUT LINEAR GUIDE

1-12 Lubrication

Lubrication

Lubrication is essential to linear motion system. Without lubrication, the friction of rolling parts increases and might be the main factor of service life shortening.

A lubricant :

- (1) Reduces friction on moving parts, thereby to prevent wearing due to raise in temperature.
- (2) Forms an oil film on rolling surfaces, thus decreasing stress that develops on the surfaces and safeguarding the system against rolling fatigue.
- (3) Covers metal surfaces with an oil film, thereby preventing rust.

To tap the full function of a linear motion system, lubrication is essential to meet the system service conditions.

※ Even the linear motion system is sealed, it cannot completely prevent the leakage of lubricants no matter how negligible the amount of leakage is at any given time. It is therefore necessary to replenish the lubricant periodically according to the operating conditions.

Classification of Lubricants

Primarily grease and sliding surface oil are used as lubricants for linear motion systems.

In general a lubricant must :

- (1) Form a strong oil film.
- (2) Reduce wear as much as possible.
- (3) Have high wear resistance.
- (4) Have high thermal stability.
- (5) Be non-corrosive.
- (6) Be highly rust-preventive.
- (7) Be free from dust and some moisture.
- (8) Be free from significant fluctuations in consistency against repeated agitation of grease.

Table1.12.1 Lubricants in General Use

Lubricant	Classification	Item
Grease	Lithium-based grease (JIS No.2) Urea-base grease (JIS No.2)	※ 4FB Grease (TBI MOTION) Daphne Eponex Grease No.2 (Idemitsu Kosan) or equivalent.
Oil	Sliding surface oil or turbine oil ISOVG 32~68	Super Multi 32 to 68 (Idemitsu Kosan) Vactra No.2S (Mobile Oil) DT Oil (Mobile Oil) Tonner Oil (Showa Shell Sekiyu) or equivalent

※ Feeding Should be performed every 100 km of travel under normal usage conditions to prevent incomplete lubrication by exhausted lubrication.

1-13 Precautions of Linear Guide

Handling

- (1) Tilting the linear guideway may cause the block falling out from the rail by their own weight.
- (2) Hitting or Dropping the linear guideway may cause its function to be damaged, even if the product looks intact.
- (3) Do not disassemble the block, this may cause contamination to enter into the carriage or decrease the installation accuracy.

Lubrication

- (1) Please remove the anti-rust oil.
- (2) Please do not mix different kinds of lubricants.
- (3) Lubrication can be varied, please consult TBI Motion before use.

Usage

- (1) The temperature of the place where linear guideways are used should not exceed 80°C. A higher temperature may damage the plastic end cap, do not exceed 100°C in friction.
- (2) Using under special conditions, such as constant vibration, high contamination or the temperature exceed our suggested...etc., please contact TBI MOTION.

Storage

When storing the linear guideway, enclose it in a package and store it in a horizontal orientation while avoiding high temperature, low temperature and high humidity.

TBI MOTION LINEAR GUIDE

2-1 The Types of TBI MOTION Linear Guide

In an effort to meet customer's requirement, TBI MOTION offers several different types of guides. Except for TR international standard series, TBI MOTION develops TR series with self lubrication system which is designed for environment with high contamination and miniature TM series for small machines and semiconductor industry.

Table 2.1.1 TBI MOTION Linear guide table with all series

Type	Height of Assembly Type	Square	Flange Mounting from Above, Mounting from Below
TR	High-Assembly	TRH-V	TRH-F
	Low-Assembly	TRS-V	TRS-F
	Middle-Assembly	TRC-V	-

Table 2.1.2 TBI MOTION Linear Guide - Type & Series

Type	Accessory	Characteristics	EndCap
TR	XN : Strong Bottom Seal+Strong Double-lip end seals	Strong dust-proof	Reinforcement Type
	UN : Strong Top Seal+Strong Bottom Seal+Double-lip end seals	Environment with high pollution	
	ZN : Strong Top Seal+Strong Bottom Seal+Strong Two Double-lip end seals		
	WW : Strong Bottom Seal+Felt+Strong Double-lip end seals	Self-lubrication/ Strong dust-proof	
	WU : Strong Top Seal+Strong Bottom Seal+Felt+Strong Double-lip end seals	Application with low rating load	
	WZ : Strong Top Seal+Strong Bottom Seal+Felt+Strong Two Double-lip end seals		
	SU : Strong Top Seal+Strong Bottom Seal+Strong Double-lip end seals+Strong Metal Scraper	Strong dust-proof / Application with low rating load	
	SZ : Strong Top Seal+Strong Bottom Seal+Strong Two Double-lip end seals+Strong Metal Scraper	Self-lubrication/ Strong dust-proof / Application with low rating load	
	DU : Strong Top Seal+Strong Bottom Seal+Strong Double-lip end seals+Felt+Strong Metal Scraper		
	DZ : Strong Top Seal+Strong Bottom Seal+Strong Two Double-lip end seals+Felt+Strong Metal Scraper	Long effects Self-lubrication/ Strong dust-proof	
BN : Strong Bottom Seal+Strong Double-lipendseals+Oil Reservoir			

※If Strengthen seals and Felt is required, please upgrade the block with enhanced end cap.

※Strengthen seals come in blue, if standard seals is required, please order it with code A, EX : XNA.

2-2 TRH / TRS / TRC International Standard Linear Guide

2-2-1 TBI MOTION The Characteristics of TR Series

Smooth Movement

TBI MOTION circulation system of Linear Guide block is designed to perform smooth movement.

High Stability

TBI MOTION Linear Guide block is designed under TBI's exclusive patent that can increase depth of material to improve the strength capacity, prevent deflection and provide high rigidity.

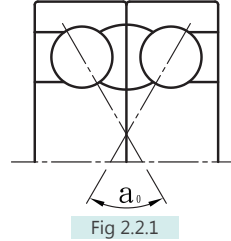

High Durability

TBI MOTION the exclusive contact point design promotes high rigidity. Moreover, self-aligning balances load rating in all directions. This design also improves performance in running accuracy and service life of the Linear Guide.

Easy Installation with Interchangeability

TBI MOTION Linear Guide is easy for installation even without fixture. The design of seal is able to combine with side seal or inner seal to save material.

2-2-2 The Structure of TR-Series

Circulation unit :

- ① Block, ② Rail, ③ End Cap, ④ Steel Balls,
- ⑤ Circulation tube.

Lubrication unit :

- ⑥ Grease nipple.

Anti-Dust Unit :

- ⑦ End Seal, ⑧ Bottom Seal, ⑨ Mounting Hole Cap.

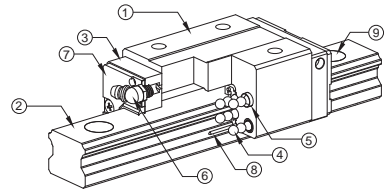

Fig 2.2.2 Material

Item	Material	Hardness
TR-Rail	S55C	HRC 58°~62°
TR-Block	SCM420H	

TBI MOTION LINEAR GUIDE

2-2 TRH / TRS / TRC International Standard Linear Guide

■ 2-2-3 TR-Series

TBI MOTION offers standard and flange type. The assembly height and category are listed below :

Table 2.2.2

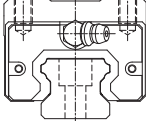
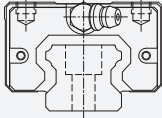
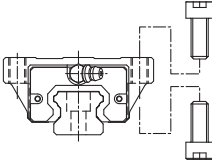
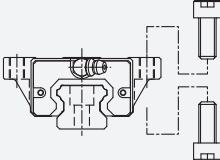
Type	Model	Shape	Height	Rail Length	Main Application
Standard	TRH-V TRC-V	Mounting from Above 	28 ↓ 90	100 ↓ 4000	<ul style="list-style-type: none"> ● Machine Centers. ● NC Lathes. ● Food Machine. ● Grinding Machines. ● CNC Machine. ● Heavy Cutting Machines. ● Punching Machine. ● Injection Molding Machine. ● Automation Equipment. ● Transportation Equipment. ● Sealing machine.
	TRS-V	Mounting from Above 	24 ↓ 60	100 ↓ 4000	
Flange	TRH-F	Mounting from above and below 	24 ↓ 90	100 ↓ 4000	
	TRS-F	Mounting from above and below 	24 ↓ 60	100 ↓ 4000	

■ 2-2-4 Nominal Model Code for Non-interchangeable TR Type

TR series can be classified into interchangeable and non-interchangeable types. The sizes are identical; the only difference between the two types is that the accuracy of non-interchangeable types could reach up to UP grade since **TBI MOTION** makes the linear guide set under strict international regulation. Interchangeable blocks and rails can be freely exchanged; however, the accuracy could be up to H grade only due to technical issue. It is much more convenient for customers who do not need linear guides with high accuracy to have interchange blocks and rails.

Non-interchangeable Type code :

T R H 20 F N - 2 - - 1200 - N - Z0 - II - K + N3 N3

① ② ③ ④ ⑤ ⑥ ⑦ ⑧ ⑨ ⑩ ⑪ ⑫ ⑬ ⑭ ⑮

① Nominal Model	② Block Type	③ Height of Assembly Type	④ Dimension
T	R : Standard X : Special	S : Low-Assembly C : Middle-Assembly H : High-Assembly	15, 20, 25, 30, 35, 45, 55, 65

⑤ Flange Type	⑥ Length of Block	⑦ Number of Block Per Rail	⑧ Accessory Code
F : With Flange V : Without Flange	S : Short N : Normal L : Long E : Extra-Long	EX : 2	□ : Standard (Please refer to page A58)

⑨ Length of Rail	⑩ Accuracy Grade	⑪ Preload	⑫ Two Sets per Axis	⑬ Rail Special Machining
Unit : mm	N : Normal H : High P : Precision SP : Super-Precision UP : Ultra-Precision	ZF : Slight Clearance Z0 : No Preload Z1 : Light Preload Z2 : Medium Preload Z3 : Heavy Preload	II	K : Tapped-Hole Rail X : Rail with Special Machining

⑭ Block Surface Treatment	⑮ Rail Surface Treatment
S : Standard	S : Standard
B1 : Black Oxidation	B1 : Black Oxidation
N1 : Hard Chrome Plating	N1 : Hard Chrome Plating
P : Phosphating	P : Phosphating
N3 : Nickel Plating	N3 : Nickel Plating
N4 : Raydent	N4 : Raydent
N5 : Chrome Plating	N5 : Chrome Plating

※ No symbol required when plating is not needed.

TBI MOTION LINEAR GUIDE

2-2 TRH / TRS / TRC International Standard Linear Guide

■ 2-2-5 Nominal Model Code for Interchangeable TR Type

Interchangeable Type of Block :

T R H 20 F N - [] - N - Z0 + B1

① ② ③ ④ ⑤ ⑥ ⑦ ⑧ ⑨ ⑩

①	②	③	④
Nominal Model	Block Type	Height of Assembly Type	Dimension
T	R : Standard X : Special	S : Low-Assembly C : Middle-Assembly H : High-Assembly	15, 20, 25, 30, 35, 45, 55, 65

⑤	⑥	⑦	⑧	⑨
Flange Type	Length of Block	Accessory Code	Accuracy Grade	Preload
F : With Flange V : Without Flange	S : Short N : Normal L : Long E : Extra-Long	□ : Standard	N : Normal	ZF : Slight Clearance Z0 : No Preload

⑩
Block Surface Treatment
□ : Standard
B1 : Black Oxidation
N1 : Hard Chrome Plating
P : Phosphating
N3 : Nickel Plating
N4 : Raydent
N5 : Chrome Plating

Interchangeable Type of Rail :

T R 20 - 4000 - N - K + B1

① ② ③ ④ ⑤ ⑥ ⑦

①	②	③	④
Nominal Model	Block Type	Dimension	Length of Rail
T	R : Standard X : Special	15, 20, 25, 30, 35, 45, 55, 65	Unit : mm

⑤	⑥	⑦
Accuracy Grade	Rail Special Machining	Block Surface Treatment
N : Normal	K : Tapped-Hole Rail X : Rail with Special Machining	□ : Standard B1 : Black Oxidation N1 : Hard Chrome Plating P : Phosphating N3 : Nickel Plating N4 : Raydent N5 : Chrome Plating

TBI MOTION LINEAR GUIDE

2-2 TRH / TRS / TRC International Standard Linear Guide

TRH-V Series Specifications

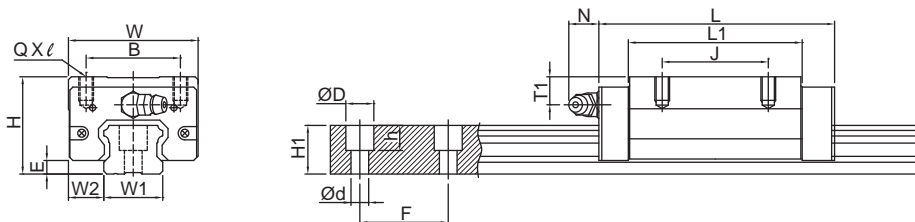

A

Linear Guide

Model No.	Assembly (mm)			Block Dimension (mm)							Rail (mm)							
	H	W2	E	W	B	J	L	L1	QXℓ	T1	Oil Hole	N	W1	H1	ØD	h	Ød	F
TRH15VN	28	9.5	3.2	34	26	26	56.9	39.5	M4X8	9.5	M4X0.7	7	15	13	7.5	6	4.5	60
TRH15VL							65.4	48										
TRH20VN	30	12	4.6	44	32	36	75.6	54	M5X7	6.5	M6X1	14	20	16.5	9.5	8.5	6	60
TRH20VE						50	99.6	78										
TRH25VN	40	12.5	5.8	48	35	35	81	59	M6X8	11.5	M6X1	14	23	20	11	9	7	60
TRH25VE						50	110	88										
TRH30VN	45	16	7	60	40	40	96.3	69.3	M8X10	11	M6X1	14	28	23	14	12	9	80
TRH30VE						60	132	105										
TRH35VN	55	18	7.5	70	50	50	109	79	M8X10	15	M6X1	14	34	26	14	12	9	80
TRH35VE						72	153	123										
TRH45VL	70	20.5	8.9	85.5	60	60	140	106	M10X15	20.5	PT1/8	12.5	45	32	20	17	14	105
TRH45VE						80	174	140										
TRH55VL	80	23.5	13	100	75	75	162	118	M12X18	21	PT1/8	12.5	53	44	23	20	16	120
TRH55VE						95	200.1	156.1										
TRH65VL	90	31.5	14	126	76	70	197	147	M16X20	19	PT1/8	12.5	63	53	26	22	18	150
TRH65VE						120	256.5	206.5										

※The above specifications provided are dedicated to XN, UN, please check table 2.2.17 for detail, if other accessories is required, please refer to page A87.

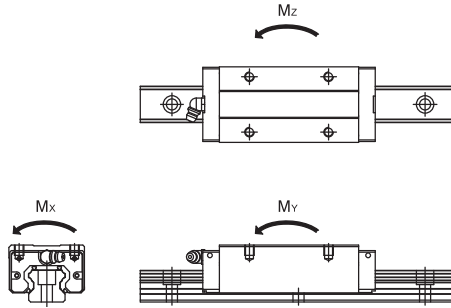

Model No.	Load Rating (kgf)		Static Permissible Moment						Weight	
			Mx (kgf-mm)		My (kgf-mm)		Mz (kgf-mm)		Block (kg)	Rail (kg/m)
	C	Co	Single Block	Single Block	Double Block	Single Block	Double Block			
TRH15VN	1206	2206	16,436	14,884	70,960	14,884	70,960	0.15	1.32	
TRH15VL	1343	2574	19,175	20,429	95,224	20,429	95,224	0.22		
TRH20VN	2050	3696	37,334	33,268	157,298	33,268	157,298	0.31	2.28	
TRH20VE	2553	5058	51,089	63,229	284,163	63,229	284,163	0.44		
TRH25VN	2581	4503	52,239	43,407	207,324	43,407	207,324	0.52	3.17	
TRH25VE	3248	6255	72,554	85,112	391,311	85,112	391,311	0.77		
TRH30VN	3807	6483	90,722	74,970	355,321	74,970	355,321	0.85	4.54	
TRH30VE	4791	9004	126,003	147,000	677,068	147,000	677,068	1.3		
TRH35VN	5090	8346	142,722	106,070	519,799	106,070	519,799	1.47	6.27	
TRH35VE	6667	12274	209,885	233,977	1,070,533	233,977	1,070,533	2.26		
TRH45VL	7572	12808	292,657	220,751	1,030,183	220,751	1,030,183	3.00	10.4	
TRH45VE	8852	16010	365,821	348,554	1,598,703	348,554	1,598,703	3.90		
TRH55VL	14703	21613	571,342	411,729	2,019,184	411,729	2,019,184	4.42	16.1	
TRH55VE	17349	27377	723,699	670,530	3,148,637	670,530	3,148,637	5.50		
TRH65VL	22526	31486	973,074	695,840	3,594,277	695,840	3,594,277	8.66	22.54	
TRH65VE	27895	42731	1,320,601	1,307,568	6,312,759	1,307,568	6,312,759	10.30		

TBI MOTION LINEAR GUIDE

2-2 TRH / TRS / TRC International Standard Linear Guide

TRH-F Series Specifications

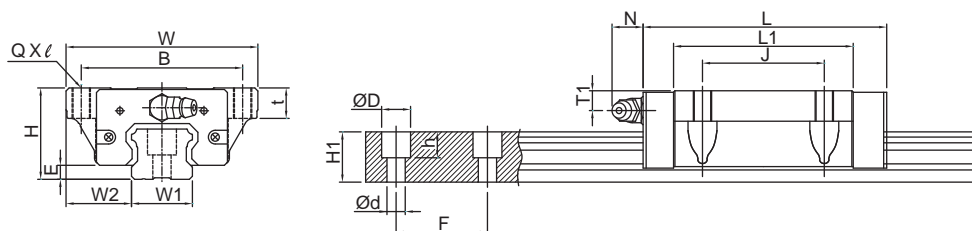

A

Linear Guide

Model No.	Assembly (mm)			Block Dimension (mm)										Rail (mm)					
	H	W2	E	W	B	J	t	L	L1	QXℓ	T1	Oil Hole	N	W1	H1	ØD	h	Ød	F
TRH15FN	24	16	3.2	47	38	30	8	56.9	39.5	M5X8	5.5	M4X0.7	7	15	13	7.5	6	4.5	60
TRH15FL								65.4	48										
TRH20FN	30	21.5	4.6	63	53	40	10	75.6	54	M6X10	6.5	M6X1	14	20	16.5	9.5	8.5	6	60
TRH20FE								99.6	78										
TRH25FN	36	23.5	5.8	70	57	45	12	81	59	M8X12	7.5	M6X1	14	23	20	11	9	7	60
TRH25FE								110	88										
TRH30FN	42	31	7	90	72	52	15	96.3	69.3	M10X15	8	M6X1	14	28	23	14	12	9	80
TRH30FE								132	105										
TRH35FN	48	33	7.5	100	82	62	15	109	79	M10X15	8	M6X1	14	34	26	14	12	9	80
TRH35FE								153	123										
TRH45FL	60	37.5	8.9	120	100	80	18	140	106	M12X18	10.5	PT1/8	12.5	45	32	20	17	14	105
TRH45FE								174	140										
TRH55FL	70	43.5	13	140	116	95	29	162	118	M14X17	11	PT1/8	12.5	53	44	23	20	16	120
TRH55FE								200.1	156.1										
TRH65FL	90	53.5	14	170	142	110	37	197	147	M16X23	19	PT1/8	12.5	63	53	26	22	18	150
TRH65FE								256.5	206.5										

※The above specifications provided are dedicated to XN, UN, please check table 2.2.17 for detail, if other accessories is required, please refer to page A87.

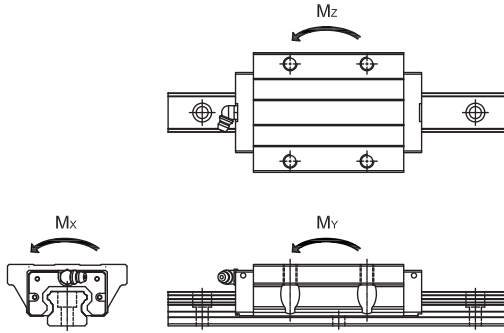

Model No.	Load Rating (kgf)		Static Permissible Moment					Weight	
			Mx (kgf-mm)		My (kgf-mm)		Mz (kgf-mm)		Block (kg)
	C	Co	Single Block	Single Block	Double Block	Single Block	Double Block		
TRH15FN	1206	2206	16,436	14,884	70,960	14,884	70,960	0.18	1.32
TRH15FL	1343	2574	19,175	20,429	95,224	20,429	95,224	0.22	
TRH20FN	2050	3696	37,334	33,268	157,298	33,268	157,298	0.39	2.28
TRH20FE	2553	5058	51,089	63,229	284,163	63,229	284,163	0.58	
TRH25FN	2581	4503	52,239	43,407	207,324	43,407	207,324	0.60	3.17
TRH25FE	3248	6255	72,554	85,112	391,311	85,112	391,311	0.85	
TRH30FN	3807	6483	90,722	74,970	355,321	74,970	355,321	1.01	4.54
TRH30FE	4791	9004	126,003	147,000	677,068	147,000	677,068	1.54	
TRH35FN	5090	8346	142,722	106,070	519,799	106,070	519,799	1.47	6.27
TRH35FE	6667	12274	209,885	233,977	1,070,533	233,977	1,070,533	2.29	
TRH45FL	7572	12808	292,657	220,751	1,030,183	220,751	1,030,183	2.80	10.4
TRH45FE	8852	16010	365,821	348,554	1,598,703	348,554	1,598,703	3.79	
TRH55FL	14703	21613	571,342	411,729	2,019,184	411,729	2,019,184	4.22	16.1
TRH55FE	17349	27377	723,699	670,530	3,148,637	670,530	3,148,637	5.6	
TRH65FL	22526	31486	973,074	695,840	3,594,277	695,840	3,594,277	9.31	22.54
TRH65FE	27895	42731	1,320,601	1,307,568	6,312,759	1,307,568	6,312,759	12.98	

TBI MOTION LINEAR GUIDE

2-2 TRH / TRS / TRC International Standard Linear Guide

TRS-V Series Specifications

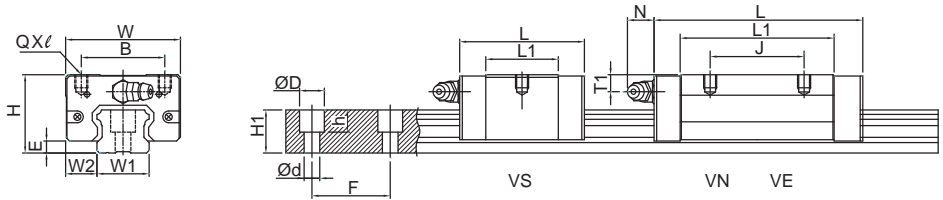

Model No.	Assembly(mm)			Block Dimension(mm)								Rail(mm)						
	H	W2	E	W	B	J	L	L1	QXl	T1	Oil Hole	N	W1	H1	ØD	h	Ød	F
TRS15VS	24	9.5	3.2	34	26	40.3	22.9	M4X5	5.5	M4X0.7	7	15	13	7.5	6	4.5	60	
TRS15VN						26	56.9											39.5
TRS20VS	28	11	4.6	42	32	49.4	27.8	M5X6	4.5	M6X1	14	20	16.5	9.5	8.5	6	60	
TRS20VN						32	68.3											46.7
TRS25VS	33	12.5	5.8	48	35	57.2	35.2	M6X6.5	4.5	M6X1	14	23	20	11	9	7	60	
TRS25VN						35	81											59
TRS30VS	42	16	7	60	40	67.4	40.4	M8X8	8	M6X1	14	28	23	14	12	9	80	
TRS30VN						40	96.3											69.3
TRS35VN	48	18	7.5	70	50	50	109	79	M8X8	8	M6X1	14	34	26	14	12	9	80
TRS35VE						72	153	123										
TRS45VN	60	20.5	8.9	86	60	60	124.5	90.5	M10X15	10.5	PT1/8	12.5	45	32	20	17	14	105

※The above specifications provided are dedicated to XN, UN, please check table 2.2.17 for detail, if other accessories is required, please refer to page A87.

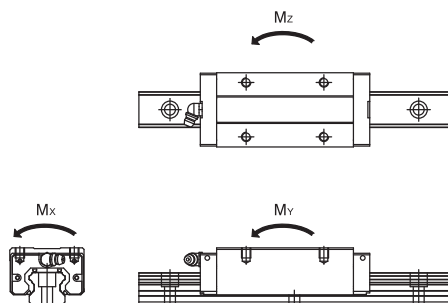

Model No.	Load Rating (kgf)		Static Permissible Moment					Weight	
			Mx (kgf-mm)	My (kgf-mm)		Mz (kgf-mm)		Block (kg)	Rail (kg/m)
	C	Co		Single Block	Single Block	Double Block	Single Block		
TRS15VS	908	1471	10,957	6,420	33,531	6,420	33,531	0.09	1.32
TRS15VN	1206	2206	16,436	14,884	70,960	14,884	70,960	0.15	
TRS20VS	1398	2140	21,615	10,700	59,798	10,700	59,798	0.15	2.28
TRS20VN	1896	3307	33,404	26,459	126,998	26,459	126,998	0.23	
TRS25VS	1943	3002	34,826	18,725	97,890	18,725	97,890	0.25	3.17
TRS25VN	2581	4503	52,239	43,407	207,324	43,407	207,324	0.39	
TRS30VS	2697	3962	55,442	26,950	154,224	26,950	154,224	0.48	4.54
TRS30VN	3807	6483	90,722	74,970	355,321	74,970	355,321	0.77	
TRS35VN	5090	8346	142,722	106,070	519,799	106,070	519,799	1.15	6.27
TRS35VE	6667	12274	209,885	233,977	1,070,533	233,977	1,070,533	1.54	
TRS45VN	6758	10887	248,758	158,011	782,271	158,011	782,271	1.98	10.4

TBI MOTION LINEAR GUIDE

2-2 TRH / TRS / TRC International Standard Linear Guide

TRS-F Series Specifications

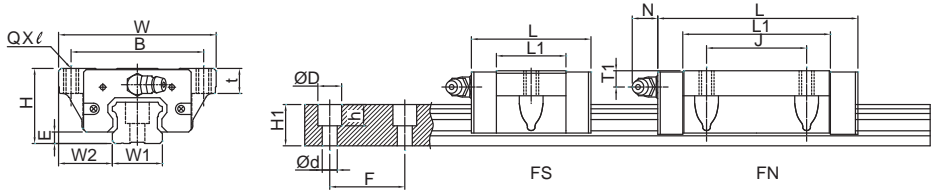

Model No.	Assembly(mm)			Block Dimension(mm)										Rail(mm)					
	H	W2	E	W	B	J	t	L	L1	QXℓ	T1	Oil Hole	N	W1	H1	ØD	h	Ød	F
TRS15FS	24	18.5	3.2	52	41	26	7	40.3	22.9	M5X7	5.5	M4X0.7	7	15	13	7.5	6	4.5	60
TRS15FN								56.9	39.5										
TRS20FS	28	19.5	4.6	59	49	32	9	49.4	27.8	M6X9	4.5	M6X1	14	20	16.5	9.5	8.5	6	60
TRS20FN								68.3	46.7										
TRS25FN	33	25	5.8	73	60	35	10	81	59	M8X10	4.5	M6X1	14	23	20	11	9	7	60

※ The above specifications provided are dedicated to XN, UN, please check table 2.2.17 for detail, if other accessories is required, please refer to page A87.

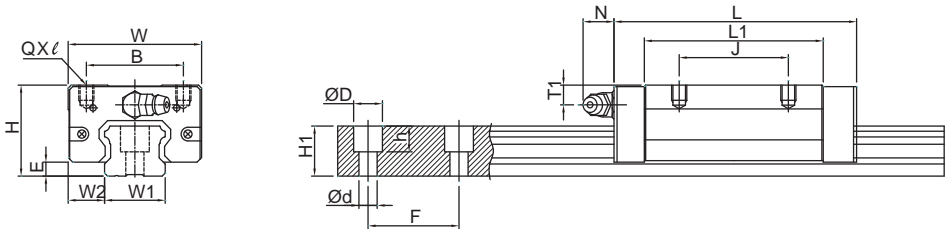

Model No.	Assembly(mm)			Block Dimension(mm)										Rail(mm)					
	H	W2	E	W	B	J	L	L1	QXℓ	T1	Oil Hole	N	W1	H1	ØD	h	Ød	F	
TRC25VE	36	12.5	5.8	48	35	50	110	88	M6X6.5	7.5	M6X1	14	23	20	11	9	7	60	

※ The above specification provided is dedicated to XN, UN, please check table 2.2.17 for detail, if other accessories is required, please refer to page A87.

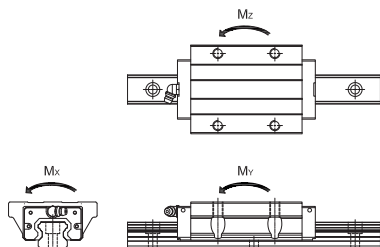

Model No.	Load Rating (kgf)		Static Permissible Moment					Weight	
			Mx (kgf-mm)	My (kgf-mm)		Mz (kgf-mm)		Block (kg)	Rail (kg/m)
	C	Co		Single Block	Single Block	Double Block	Single Block		
TRS15FS	908	1471	10,957	6,420	33,531	6,420	33,531	0.12	1.32
TRS15FN	1206	2206	16,436	14,884	70,960	14,884	70,960	0.19	
TRS20FS	1398	2140	21,615	10,700	59,798	10,700	59,798	0.19	2.28
TRS20FN	1896	3307	33,404	26,459	126,998	26,459	126,998	0.29	
TRS25FN	2581	4503	52,239	43,407	207,324	43,407	207,324	0.51	3.17

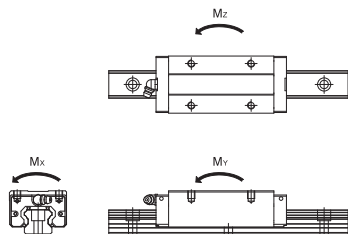

Model No.	Load Rating (kgf)		Static Permissible Moment					Weight	
			Mx (kgf-mm)	My (kgf-mm)		Mz (kgf-mm)		Block (kg)	Rail (kg/m)
	C	Co		Single Block	Single Block	Double Block	Single Block		
TRC25VE	3248	6255	72,554	85,112	391,311	85,112	391,311	0.65	3.17

TBI MOTION LINEAR GUIDE

2-2 TRH / TRS / TRC International Standard Linear Guide

■ 2-2-6 The Standard Length and Maxima Length of Linear Rail

TBI MOTION offer our customers standard and customized rail length to meet the requirement of our customers. TBI suggests that when ordering customized rail length, to prevent unstable running performance after mounting, the end cap value G should be no greater than 1/2F.

$$L = [n-1] \cdot F + 2 \cdot G$$

L : Total Length of Rail (mm)

n : Number of Mounting Holes

F : Distance Between Any Two Holes (mm)

G : Distance from the Center of the Last Hole to the Edge (mm)

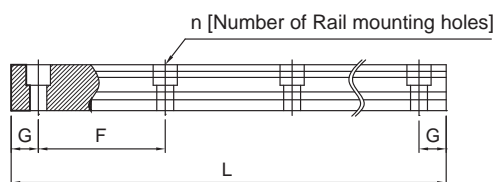

Fig 2.2.3

Table 2.2.3

Item	TR15	TR20	TR25	TR30	TR35	TR45	TR55	TR65
F : Pitch	60	60	60	80	80	105	120	150
G : Suggested Distance to End	20	20	20	20	20	22.5	30	35
L : Max. Length	4000	4000	4000	4000	4000	4000	4000	4000

■ 2-2-7 Mounting Type of Linear Rail

Besides the standard top mounting type, *TBI MOTION* also offers bottom mounting type rails.

Table 2.2.4

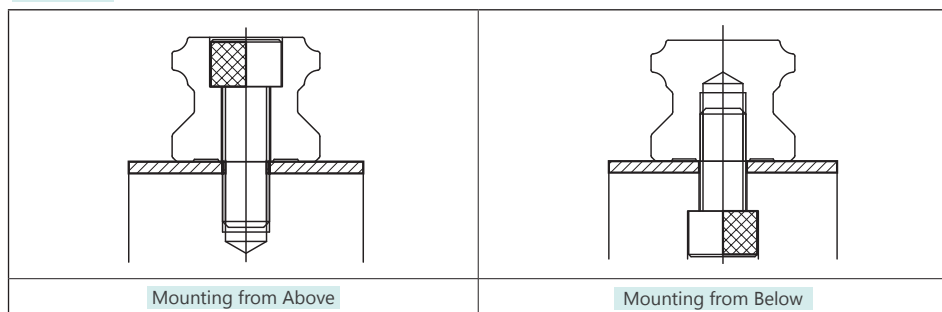

Mounting from Above

Mounting from Below

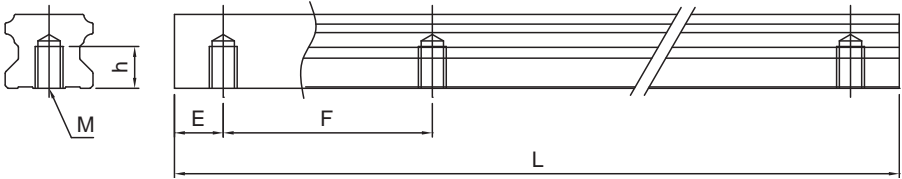

Fig 2.2.4 Mounting from below

Table 2.2.5 Rail Size Chart

Unit : mm

	M	h	E	F
TR15	M5 · 0.8	8	20	60
TR20	M6 · 1	10	20	60
TR25	M6 · 1	12	20	60
TR30	M8 · 1.25	15	20	80
TR35	M8 · 1.25	17	20	80
TR45	M12 · 1.75	24	22.5	105
TR55	M14 · 2	24	30	120
TR65	M20 · 2.5	30	35	150

TBI MOTION LINEAR GUIDE

2-2 TRH / TRS / TRC International Standard Linear Guide

■ 2-2-8 Accuracy Standard

The accuracy standards of TR-Series range, from normal (N), high (H), precision (P), super-precision (SP) and ultra-precision (UP). It allows our user to choose according to the accuracy standards of the equipment.

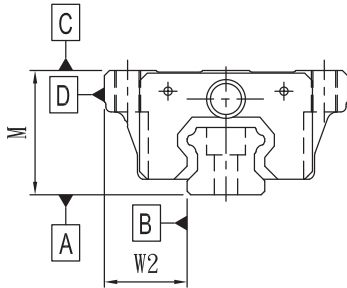
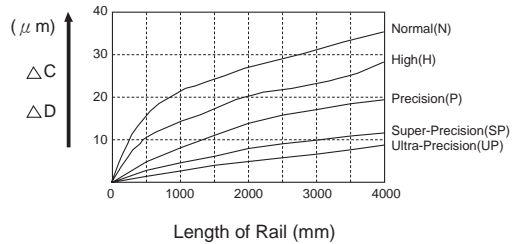

Fig 2.2.5 Accuracy Standard



TR Rail Length and Running Accuracy.

Fig 2.2.6

Table 2.2.6 TR-Accuracy of Running Parallelism

TR Rail Length (mm)	Accuracy (μm)				
	N	H	P	SP	UP
0~125	5	3	2	1.5	1
125~200	5	3.5	2	1.5	1
200~250	6	4	2.5	1.5	1
250~315	7	4.5	3	1.5	1
315~400	8	5	3.5	2	1.5
400~500	9	6	4.5	2.5	1.5
500~630	16	11	6	2.5	1.5
630~800	18	12	7	3	2
800~1000	20	14	8	4	2
1000~1250	22	16	10	5	2.5
1250~1600	25	18	11	6	3
1600~2000	28	20	13	7	3.5
2000~2500	30	22	15	8	4
2500~3000	32	24	16	9	4.5
3000~3500	33	25	17	11	5
3500~4000	34	26	18	12	6

Table 2.2.7

Unit : mm

Accuracy Standard										
TR 15 20						TR 25 30 35				
Accuracy Standard	Normal	High	Precision	Super Precision	Ultra Precision	Normal	High	Precision	Super Precision	Ultra Precision
Item	N	H	P	SP	UP	N	H	P	SP	UP
Tolerance for height M	±0.1	±0.03	0 -0.03	0 -0.015	0 -0.008	±0.1	±0.04	0 -0.04	0 -0.02	0 -0.01
Tolerance for height M difference among Linear Guide Block	0.02	0.01	0.006	0.004	0.003	0.02	0.015	0.007	0.005	0.003
Tolerance for rail-to-block lateral distance W2	±0.1	±0.03	0 -0.03	0 -0.015	0 -0.008	±0.1	±0.04	0 -0.04	0 -0.02	0 -0.01
Tolerance for rail-to-block lateral distance W2 difference among Linear Guide Block	0.02	0.01	0.006	0.004	0.003	0.03	0.015	0.007	0.005	0.003
Running parallelism of Linear Guide Block surface [C] with respect to surface [A]	Δ C, TR Rail Length and Running Accuracy (Fig 2.2.5)					Δ C, TR Rail Length and Running Accuracy (Fig 2.2.5)				
Running parallelism of Linear Guide Block surface [D] with respect to surface [B]	Δ D, TR Rail Length and Running Accuracy (Fig 2.2.5)					Δ D, TR Rail Length and Running Accuracy (Fig 2.2.5)				
Accuracy Standard										
TR 45 55						TR 65				
Accuracy Standard	Normal	High	Precision	Super Precision	Ultra Precision	Normal	High	Precision	Super Precision	Ultra Precision
Item	N	H	P	SP	UP	N	H	P	SP	UP
Tolerance for height M	±0.1	±0.05	0 -0.05	0 -0.03	0 -0.02	±0.1	±0.07	0 -0.07	0 -0.05	0 -0.03
Tolerance for height M difference among Linear Guide Block	0.03	0.015	0.007	0.005	0.003	0.03	0.02	0.01	0.007	0.005
Tolerance for rail-to-block lateral distance W2	±0.1	±0.05	0 -0.05	0 -0.03	0 -0.02	±0.1	±0.07	0 -0.07	0 -0.05	0 -0.03
Tolerance for rail-to-block lateral distance W2 difference among Linear Guide Block	0.03	0.02	0.01	0.007	0.005	0.03	0.025	0.015	0.01	0.007
Running parallelism of Linear Guide Block surface [C] with respect to surface [A]	Δ C, TR Rail Length and Running Accuracy (Fig 2.2.5)					Δ C, TR Rail Length and Running Accuracy (Fig 2.2.5)				
Running parallelism of Linear Guide Block surface [D] with respect to surface [B]	Δ D, TR Rail Length and Running Accuracy (Fig 2.2.5)					Δ D, TR Rail Length and Running Accuracy (Fig 2.2.5)				

2-2 TRH / TRS / TRC International Standard Linear Guide

■ 2-2-9 Determining the Magnitude of a Preload

What's Preload

Using larger rolling elements helps strengthen the entire rigidity of the block while there exists clearance within ball circulation.

Increasing preload would decrease the vibration and reduce the corrosion caused by running back and forth. However, it would also add the workload within those rolling elements. The greater the preload is, the greater the inner workload is. Therefore, choosing preload has to consider the effect carefully between vibration and preload.

Table 2.2.8 Preload Grade

C : Dynamic load rating

Grade	Symbol	Preload Force
Slight Clearance	ZF	0
No Preload	Z0	0
Light Preload	Z1	0.02C
Medium Preload	Z2	0.05C
Heavy Preload	Z3	0.07C

Table 2.2.9 TR Series Radial Clearances

Unit : μm

Preload Model No.	ZF	Z0	Z1	Z2	Z3
TR15	5~12	-4~4	-12~-5	-20~-13	-28~-21
TR20	6~14	-5~5	-14~-6	-23~-15	-32~-24
TR25	7~16	-6~6	-16~-7	-26~-17	-36~-27
TR30	8~18	-7~7	-18~-8	-29~-19	-40~-30
TR35	9~20	-8~8	-20~-9	-32~-21	-44~-33
TR45	10~22	-9~9	-22~-10	-35~-23	-48~-36
TR55	11~24	-10~10	-24~-11	-38~-25	-52~-39
TR65	12~26	-11~11	-26~-12	-41~-27	-56~-42

Table 2.2.10 The Difference between Interchangeability and Non-Interchangeability

Slight Clearance	Non-Interchangeable					Interchangeable
	UP	SP	P	H	N	N
Preload			Z0	Z0	ZF	ZF
	Z1	Z1	Z1	Z1	Z0	Z0
	Z2	Z2	Z2	Z2	Z1	Z1
	Z3	Z3	Z3	Z3	Z2	

■ 2-2-10 Mounting Location of Grease Nipples

The standard location of the grease nipple is at both ends of the block, but the nipple can be mounted at each side of block. For lateral installation, we recommend that the nipple be mounted at the non-reference side, otherwise please contact us. It is possible to perform lubrication by using the oil-piping joint.

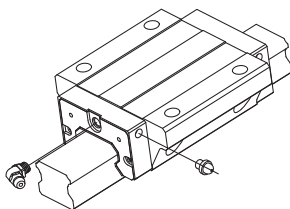

Fig 2.2.7 Mounting Location

Table 2.2.11 The Lubricant Amount for a Block Filled with Grease

Size	Grease (cm ³)
TR15	1.3
TR20	2.5
TR25	2.5
TR30	7
TR35	9
TR45	15.2
TR55	40
TR65	75

Table 2.2.12 Oil Refilling Rate

Size	Oil refilling rate (cm ² /hr)
TR15	0.2
TR20	0.2
TR25	0.3
TR30	0.3
TR35	0.3
TR45	0.4
TR55	0.5
TR65	0.6

TBI MOTION LINEAR GUIDE

2-2 TRH / TRS / TRC International Standard Linear Guide

■ 2-2-11 Grease Nipples

Table 2.2.13 Grease Nipples

Model	Accessory Code	Grease Nipple Code	Size
TR15	XN, UN	SD-020	
	SU, ZN	SD-024	
	SZ	SD-066	
	WW, WU, WZ, DU, DZ	-	
TR20 TR25 TR30	XN, UN	SD-021	
	SU	SD-025	
	SZ	SD-026	
	ZN	SD-075	
	WW, WU, WZ, DU, DZ	-	
TR35	XN, UN	SD-021	
	SU, ZN	SD-026	
	SZ	SD-060	
	WW, WU, WZ, DU, DZ	-	
TR45	XN, UN	SD-011	
	SZ, ZN	SD-027	
	SU	SD-068	
	WW, WU, WZ, DU, DZ	-	
TR55	XN, UN	SD-011	
	SZ, ZN	SD-059	
	SU	SD-068	
	WW, WU, WZ	-	
TR65	XN, UN	SD-011	
	SU	SD-059	
	SZ, ZN	SD-058	
	WW, WU, WZ	-	

A

Linear Guide

Table 2.2.14 Types of Lubrication Coupler

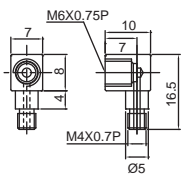
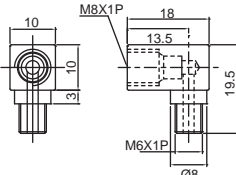
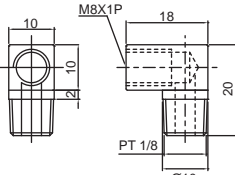
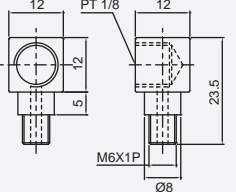
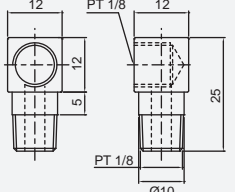
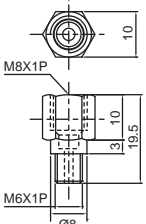
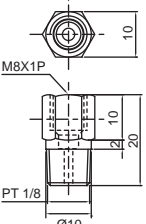
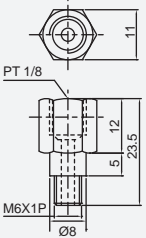
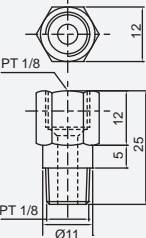
Model	TR15	TR20, 25, 30, 35	TR45, 55, 65
Types of Lubrication Coupler	<p>SD-037</p> 	<p>SD-038</p> 	<p>SD-039</p> 
		<p>SD-029</p> 	<p>SD-040</p> 
		<p>SD-041</p> 	<p>SD-042</p> 
		<p>SD-043</p> 	<p>SD-044</p> 

TBI MOTION LINEAR GUIDE

2-2 TRH / TRS / TRC International Standard Linear Guide

■ 2-2-12 J-Flow System

When the linear guide sets up on the side mount as the (Fig 2.2.8) shows. It is hard to equally distribute the lubrication on the race groove due to gravity. The common way to solve this is to grease from the side of the block; however, such method is almost impossible when the application is already space limited. TBI Motion provides a unique solution to overcome the dilemma by implementing the J-Flow System. The J-Flow System is equipped with two optional screw-tightening lubrication spot on both ends of linear block with the special internal lubricating path which allows the lubrication to travel in both direction by simply tightening or loosening the lubrication screw.

A

Linear Guide

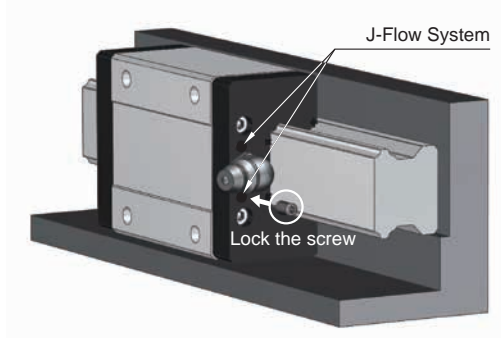

Fig 2.2.8 J-Flow System

The oil flows upward

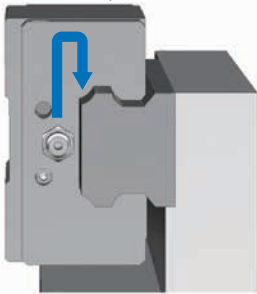

Fig 2.2.9 The oil sail against the gravity to lubricate the circulation path

When stop, slowly shed

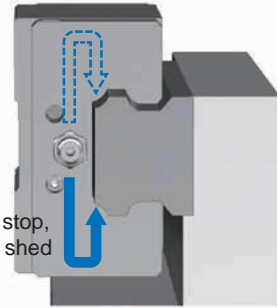

Fig 2.2.10 The oil flows downward through optional screw in spot when the feeding stops

■ 2-2-13 Strong Dust-proof/Self-Lubricating Linear Guide Series Accessory

TBI MOTION Linear Guide with Double-lip End Seal

Characteristics of **TBI MOTION** Dust-proof End Seal

1. Seal Function : Seal design from single-lip to double-lip is to prevent more dust from going into the block.
2. Hardness : Heat treatment harden the end seal to absorb impact while operating.
3. Environment : Better solution for dust-proof when using double seals in environment with high contamination.
4. Lifetime Extension : Double-lip seal prevents dust go into the block and provides a solution for block damage due to dust issue.

Characteristics of **TBI MOTION** Metal Scraper

The scraper decreases the possibility of high temperature iron chip or dust entering the block.

Characteristics of **TBI MOTION** Self-Lubricating Linear Guide Series

There is a Felt accessory between end cap and seals. Felt with oil lubricates the rail when operating and grease nipple is not needed. The design is shown below. (Fig 2.2.11)

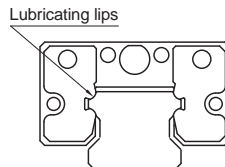

Fig 2.2.11

Example

WZ (Top Seal+Bottom Seal+Two Double-lip end seals+Felt)

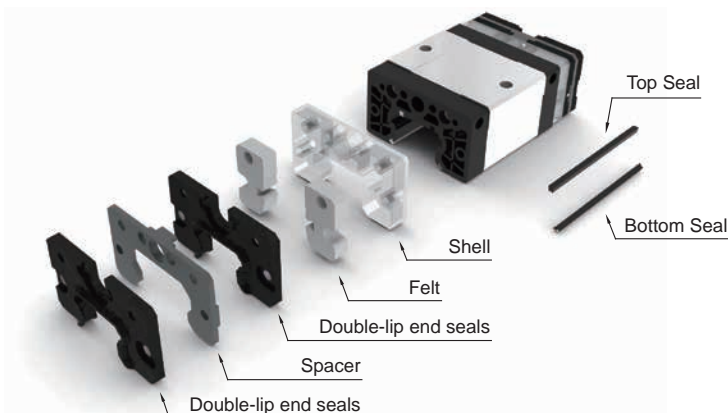

Fig 2.2.12

TBI MOTION LINEAR GUIDE

2-2 TRH / TRS / TRC International Standard Linear Guide

Life Comparison

As shown in the chart, the lifetime of self-lubricating blocks is twice as long as standard series blocks.

Table 2.2.15 Test

	Control Group	Experiment Group
Test Environment	Standard	Self-Lubricating
Model No.	TRH20VN	TRH20VN
Load Rating	1000 kg	1000 kg
Speed	6 m/min	6 m/min
Travel Length	600 mm	600 mm

※ No extra grease is added during the test for both standard series and self-lubricating series.

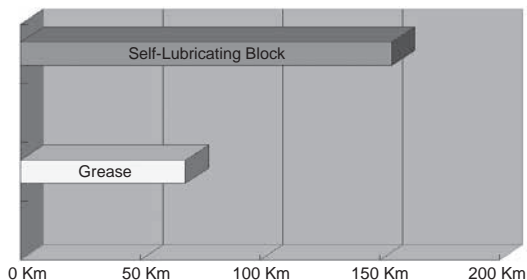
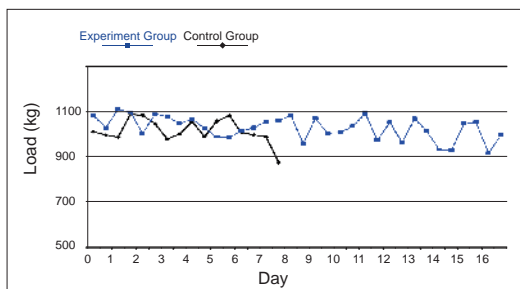

Instructions of Self-Lubricating Block Felt

The felt has already filled in with lubricant. It is suggested to soak the whole felt in the oil tank for more than 8 hours before using. Felt can be refilled with any approved lubricant depending on the requirement (ISOVG 32~68).

Characteristics of Suggested Oil :

- (1) Form a strong oil film.
- (2) Reduce wear as much as possible.
- (3) Have high wear resistance.
- (4) Have high thermal stability.
- (5) Be noncorrosive.
- (6) Be highly rust-preventive.
- (7) Be free from dust and some moisture.

Characteristics of Block Felt

- (1) Easy Assembly and Removal - Only screws are needed when assembling and disassembling the accessory.
- (2) Environmental Friendly - No need of grease nipple and other equipment to save energy.
- (3) Low Maintenance - Prevents oil leaking, making it a ideal solution for clean working environments.
- (4) Strong Dust-Proof - With dust-proof accessory, service life is extended.

The Suggested Operating Temperature

The suggested operating temperature is between -10°C to 60°C. If operating temperature is over suggested criteria, please contact TBI MOTION.

2-2 TRH / TRS / TRC International Standard Linear Guide

Self-Lubricating Linear Guide Oil Cassette Units

Self lubrication system is designed with lubrication mechanism between end cap and wiper. The structure units are shown as follow. The Cassette unit is comprised with fluid channel which is soaked with oil and act to release the lubricants thoroughly during operation. With this smart and simple design, the linear guide can be lubricated without extra oil feeding units thus minimize unnecessary parts and waste which triggers higher cost and higher risk in mounting error.

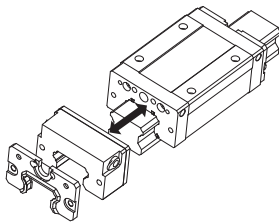

Fig 2.2.13 Installation Method

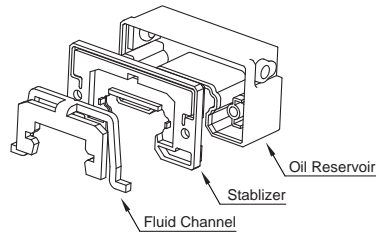

Fig 2.2.14 Cassette Unit

Characteristics of Self-Lubricating Units

- (1) No extra oil feeding unit is required.
- (2) Applicable in highly required clean environment.
- (3) May maintain lubrication for a period of time.
- (4) Lubricates thoroughly in any operating positions.
- (5) Interchangeable to any grease/oil.
- (6) Improves dust-proof efficiency when assembled to the block.

Applications

- (1) Machine Tool
- (2) Industrial Automation : Plastic and rubber manufacturers, Typography, Paper, Textiles, Food.
- (3) Electronic and Component manufacturing : Semiconductor, X-Y Platform, Measurement, Equipment
- (4) Others : Medical Equipment, Conveyers

Characteristics of Lubrication Oil

The Self lubrication cassette is filled in with Synthetic Hydro Carbon oil (SHC). The performance of the oil is list as follows :

- (1) Solvent refined oil without wax and impurity.
- (2) High grade of consistency in extreme temperature.
- (3) Corrosion free to metal and high polymer.
- (4) Unique woven texture provides oil film on the contact point to prevent wear.
- (5) High chemical stability and durability.

Table 2.2.16

Character	Color		Clear Yellow
Ratio	15/4°C		0.860
Viscosity	100°C	c S t	137.47
	40°C		1570.68
Viscosity Index	—		120
Fluid	°C		-30
Flash Point	°C		243
Evaporation Rate	100°C · 24 hr		<0.15%
Copper Corrosion Test	100°C · 24 hr		Pass
Resin Test	80°C · 24 hr Polystyrene		Pass
Operation Temperature (°C)			-30~160

2-2 TRH / TRS / TRC International Standard Linear Guide

■ 2-2-14 Dust-proof/Accessory

If the following accessories are needed, please add the code followed by the model number.

Special Option : Steel end seal, Steel end cap, Cover Strip, please contact TBI Motion.

Standard Accessories :

End seal and Bottom seal

To prevent life reduction caused by iron chips or dust entering the block.

Other Accessories :

Top Seal

Efficiently prevents dust from the surface of rail or tapping hole getting inside the block.

Double end seal

Enhances the wiping effect, foreign matter can be completely wiped off.

Double-lip end seals

Double-lip end seal is suitable for environment with high contamination.

Characteristics of *TBI MOTION* Metal Scraper

The scraper decreases the possibility of high temperature iron chip or dust entering the block.

Felt

Double-lip end seal is suitable for environment with high contamination. Felt lubricates the ball track of the rail extending the lifetime. This accessory is suitable for light rating load environment.

Oil Reservoir

After installation, oil reservoir can extend lubricating effect.

Table 2.2.17 Codes of Accessories

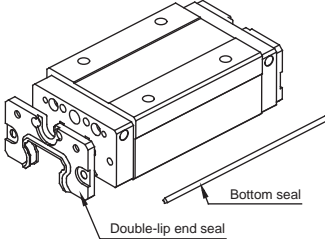
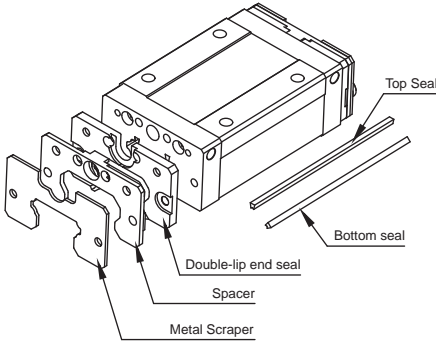
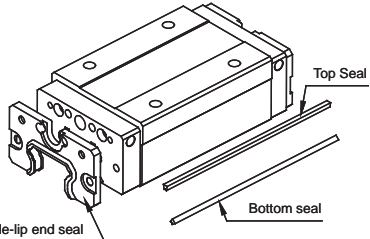
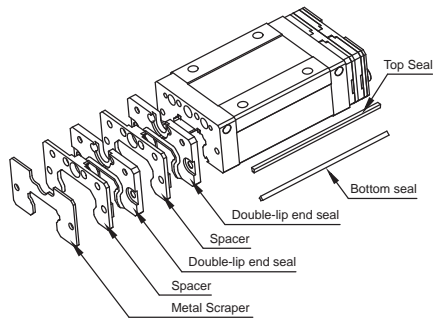
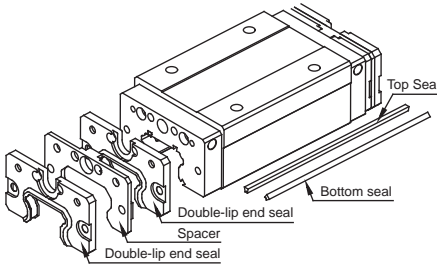
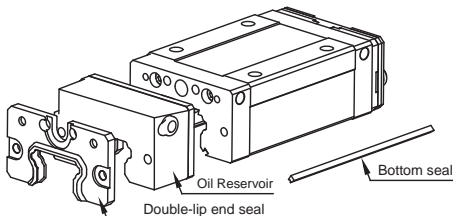
<p>XN (Double-lip end seals+Bottom seals)</p>	<p>SU (Double-lip end seals+Bottom seals+Top seals+Metal Scraper)</p>
 <p>Diagram showing the XN configuration with a double-lip end seal and a bottom seal.</p>	 <p>Diagram showing the SU configuration with a top seal, double-lip end seal, spacer, and metal scraper.</p>
<p>UN (Double-lip end seals+Bottom seals+Top seals)</p>	<p>SZ (Two Double-lip end seals+Bottom seals+Top seals+Metal Scraper)</p>
 <p>Diagram showing the UN configuration with a top seal, double-lip end seal, and bottom seal.</p>	 <p>Diagram showing the SZ configuration with two double-lip end seals, spacer, metal scraper, top seal, and bottom seal.</p>
<p>ZN (Two Double-lip end seals+Bottom seals+Top seals)</p>	<p>BN (Double-lip end seals+Bottom seals+Oil Reservoir)</p>
 <p>Diagram showing the ZN configuration with two double-lip end seals, spacer, top seal, and bottom seal.</p>	 <p>Diagram showing the BN configuration with an oil reservoir, double-lip end seal, and bottom seal.</p>

※ After selection of different accessories increase the overall length of the slider, see table 2.2.18.

TBI MOTION LINEAR GUIDE

2-2 TRH / TRS / TRC International Standard Linear Guide

WW (Double-lip end seals+Bottom seals+Felts)

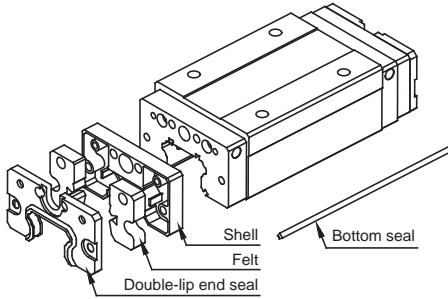

DU (Double-lip end seals+Bottom seals+Top seals+Felts+Metal Scraper)

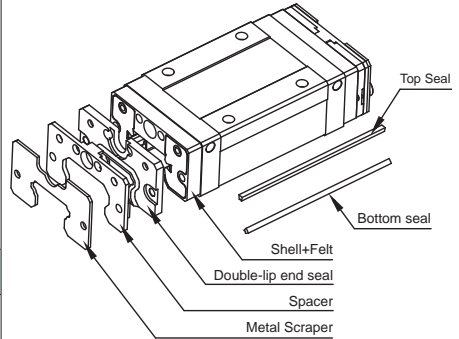

WU (Double-lip end seals+Bottom seals+Top Seals+Felts)

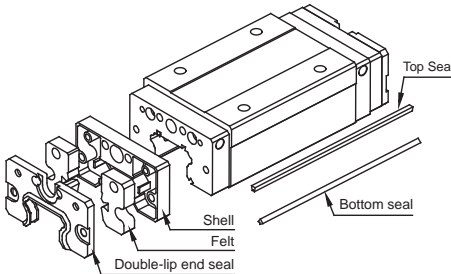

DZ (Two Double-lip end seals+Bottom seals+Top seals+Felts+Metal Scraper)

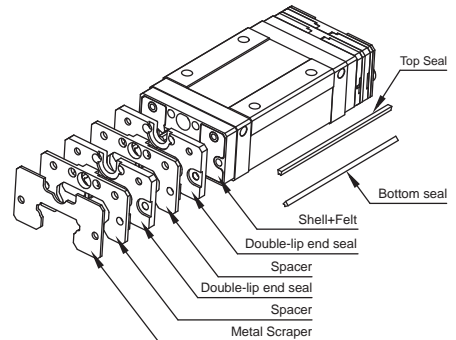

WZ (Two Double-lip end seals+Bottom seals+Top Seals+Felts)

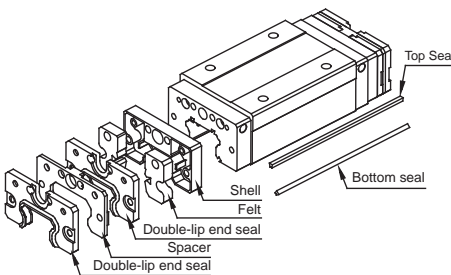

Table 2.2.18 TR Type Block Length of Accessories

Unit : mm

Two Double-lip end seals (ZN)								
Length of Block Code \ Type	TR15	TR20	TR25	TR30	TR35	TR45	TR55	TR65
S	47.9	58.4	65.6	76.4	84.7	-	-	-
N	64.5	TRS (77.3) TRH (84.6)	89.4	105.3	118	134.5	-	-
L	-	-	-	-	-	150	173	208
E	-	108.6	118.4	141	162	184	211.1	267.5

Double-lip end seals+Felt (WW, WU)								
Length of Block Code \ Type	TR15	TR20	TR25	TR30	TR35	TR45	TR55	TR65
S	51.8	60.9	68.7	78.9	87.2	-	-	-
N	68.4	TRS (79.8) TRH (87.1)	92.5	107.8	120.5	136	-	-
L	-	-	-	-	-	151.5	-	-
E	-	111.1	121.5	143.5	164.5	185.5	-	-

Two Double-lip end seals+Felt (WZ)								
Length of Block Code \ Type	TR15	TR20	TR25	TR30	TR35	TR45	TR55	TR65
S	59.4	69.9	77.1	87.9	96.2	-	-	-
N	76	TRS (88.8) TRH (96.1)	100.9	116.8	129.5	146	-	-
L	-	-	-	-	-	161.5	-	-
E	-	120.1	129.9	152.5	173.5	195.5	-	-

Double-lip end seals+Metal Scraper (SU)								
Length of Block Code \ Type	TR15	TR20	TR25	TR30	TR35	TR45	TR55	TR65
S	45.3	54.4	62.2	72.4	80.7	-	-	-
N	61.9	TRS (73.3) TRH (80.6)	86	101.3	114	129.5	-	-
L	-	-	-	-	-	145	167	202
E	-	104.6	115	137	158	179	205.1	261.5

TBI MOTION LINEAR GUIDE

2-2 TRH / TRS / TRC International Standard Linear Guide

Table 2.2.18 TR Type Block Length of Accessories

Unit : mm

Two Double-lip end seals+Metal Scraper (SZ)								
Length of Block Code \ Type	TR15	TR20	TR25	TR30	TR35	TR45	TR55	TR65
S	52.9	63.4	70.6	81.4	89.7	-	-	-
N	69.5	TRS (82.3) TRH (89.6)	94.4	110.3	123	139.5	-	-
L	-	-	-	-	-	155	178	213
E	-	113.6	123.5	146	167	189	216.1	272.5

Double-lip end seals+Felt+Metal Scraper (DU)								
Length of Block Code \ Type	TR15	TR20	TR25	TR30	TR35	TR45	TR55	TR65
S	56.8	65.9	73.7	83.9	92.2	-	-	-
N	73.4	TRS (84.8) TRH (92.1)	97.5	112.8	125.5	141	-	-
L	-	-	-	-	-	156.5	-	-
E	-	116.1	126.5	148.5	169.5	190.5	-	-

Two Double-lip end seals+Felt+Metal Scraper (DZ)								
Length of Block Code \ Type	TR15	TR20	TR25	TR30	TR35	TR45	TR55	TR65
S	64.4	74.9	82.1	92.9	101.2	-	-	-
N	81	TRS (93.8) TRH (101.1)	105.9	121.8	134.5	151	-	-
L	-	-	-	-	-	166.5	-	-
E	-	125.1	134.9	157.5	178.5	200.5	-	-

Double-lip end seals+Oil Reservoir (BN)								
Length of Block Code \ Type	TR15	TR20	TR25	TR30	TR35	TR45	TR55	TR65
S	55.8	66.4	73.2	83.4	91.7	-	-	-
N	72.4	TRS (85.3) TRH (92.6)	97	112.3	125	144	-	-
L	-	-	-	-	-	159.5	-	-
E	-	116.6	126	148	169	193.5	-	-

A

Linear Guide

Dust-proof Rails

Once the Linear Guide is operating in a cutting machine, dust and foreign matter that enter the Linear Guide may cause abnormal wear and shorten the service life.

Linear Guide rail mounting-hole cap

Chips and foreign matter clogging the mounting holes of a Linear Guide rail may enter the Linear Guide block. To prevent this situation, the mounting holes must be closed with dedicated caps, which must be installed to flush with the Linear Guide rail top surface. To insert a dedicated cap into a mounting hole, drive the cap in using a plastic hammer with a flat metal pad placed over the cap until it matches with the Linear Guide rail top surface. (Fig 2.2.15)

Rail with tapped holes

Fixing a rail with tapped hole is different from fixing a standard one. A major strength of it is the shape of the tapped hole ; dust and chippings would not enter. (Fig 2.2.15)

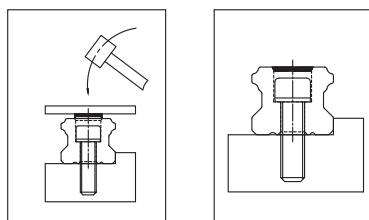

Fig 2.2.15 Dust-proof

■ 2-2-15 Friction

The figure showed in the chart is the maximum friction. (Table 2.2.20)

Table 2.2.20 End Cap friction rate

Unit : kgf

Model No.	End Cap friction rate (Max)
TR15	0.25
TR20	0.35
TR25	0.4
TR30	0.5
TR35	0.7
TR45	1.3
TR55	1.6
TR65	2

2-2 TRH / TRS / TRC International Standard Linear Guide

■ 2-2-16 Mounting-Surface Dimensional Tolerance

TR series Linear Guide is a Four-Way Equal-Load design, a slight dimensional error in the mounting surface can be absorbed by the self-adjusting capability, thus ensuring smooth linear motion. In the table below are the dimensional tolerances for the mounting surface of TR Linear Guide.

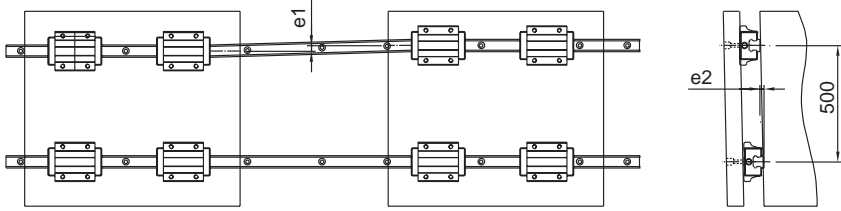

Fig 2.2.16

Table 2.2.21

Unit : μm

Model No.	Tolerance for Parallelism Between Two Axis(e1)					Tolerance for Parallelism Between Two Axis(e2)				
	Z3	Z2	Z1	Z0	ZF	Z3	Z2	Z1	Z0	ZF
TR15	-	-	18	25	35	-	-	85	130	190
TR20	-	18	20	25	35	-	50	85	130	190
TR25	15	20	22	30	42	60	70	85	130	195
TR30	20	27	30	40	55	80	90	110	170	250
TR35	22	30	35	50	68	100	120	150	210	290
TR45	25	35	40	60	85	110	140	170	250	350
TR55	34	45	50	70	98	130	170	210	300	410
TR65	42	55	60	80	105	150	200	250	350	460

2-3 TM Miniature Linear Guide

■ 2-3-1 The Characteristics of TM Series

Dust-Proof Design

The stainless bottom seal is the innovative new design of TM series. It prevents effectively the abnormal chips getting into the ball track from the bottom side of the block and keep the good running performance and extend the service life of the slider because the friction is low by keeping some small backlash between the slider and rail.

Standard end seals provide extreme protection from dust, metal scrapers to maintain long service life and shorten maintenance period. Unique low friction seal lips provide best smoothness and lower friction.

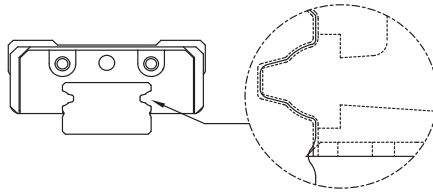

Fig 2.3.1

High Tensile Performance Stainless Steel Reinforcement Plate

Dual fully covered stainless steel plates design delivers the best coverage for plastic on each ends. Stainless steel screws are used to strength the rigidity, protection with end cap in order to sustain higher operational speed $V_{max} = 5 \text{ m/s}$, $\alpha_{max} = 300 \text{ m/s}$. When reinforcement plates and dust-proof seal is equipped to a Linear Block, they can function as a scraper.

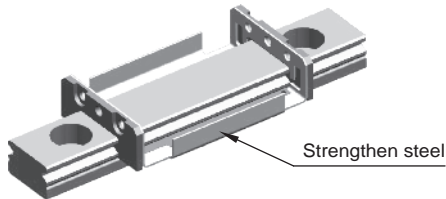

Fig 2.3.2

High Loading and Moment Capacity Performance

TM Miniature Linear Guide series uses two row circulation with Gothic 45° contact angle on the rail groove to achieve equal load capacity in four directions. Larger steel balls are used to enhance the loading and torsion resistance performance in limited space.

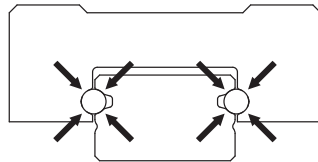

Fig 2.3.3 The Gothic 45° four-direction load structure

2-3 TM Miniature Linear Guide

2-3-2 The Structure of TM-series

Recirculation system : End cap + Recirculation tube + Ball retainer

Sealing system : Side + Bottom system

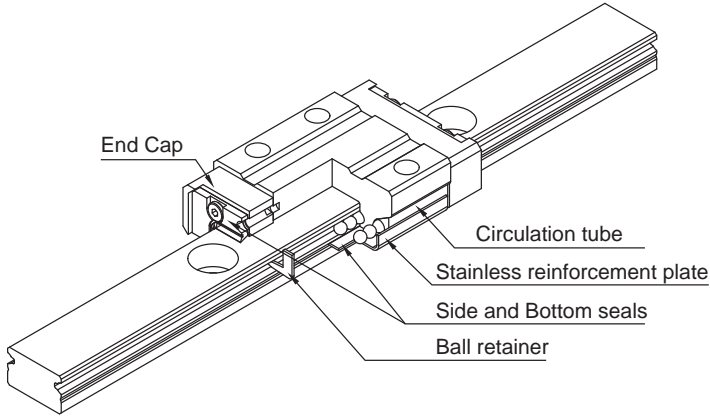

Fig 2.3.4

2-3-3 Accuracy

Miniature Linear Guide TM-series provides P, H, N three accuracy grades for customer to choose.

Table 2.3.1

	Accuracy (μm)		Precision P	High H	Normal N
	Tolerance of Height H	H		± 10	± 20
Variation of height with different block on same spot of the rail	ΔH		7	15	25
Tolerance of width W2	W2		± 15	± 25	± 40
Variation with width on different block on same spot of the rail	$\Delta W2$		10	20	30

Speed

The maximum acceleration of TM-series can reach $V_{max} > 5 \text{ m/s}$, $a_{max} = 300 \text{ m/s}^2$ (60 m/s without preload).

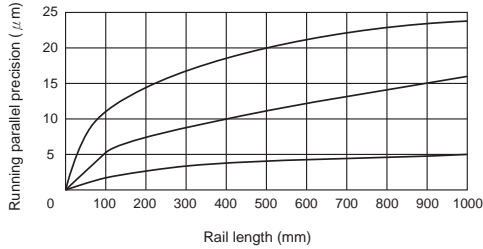

Fig 2.3.5 Running parallel precision slide relative to the rails datum

■ 2-3-4 Preload

Preload Value

Miniature Linear Guide TM-series offers three preloading level, ZF, Z0, Z1. A proper preload enhances performance on rigidity, precision, and torsion resistance; However, an improper preload shorten service life and increase friction.

Table 2.3.2 Table

Preload Grade	Pressure	Preload(μm)				Applications
		7	9	12	15	
ZF	Slight Clearance	+4~0	+4~0	+5~0	+6~0	Running smoothly
Z0	Zero Preload	+2~0	+2~0	+2~0	+3~0	Precision applications, Running smoothly
Z1	Light Preload	0~3	0~4	0~5	0~6	High steel, Precision applications, Running smoothly

Permissible Operational Temperature

The Miniature Linear Guide TM-series is sufficient to operate between $-40^{\circ}\text{C} \sim +80^{\circ}\text{C}$. For sudden temperature rise the temperature can reach up to $+100^{\circ}\text{C}$.

TBI MOTION LINEAR GUIDE

2-3 TM Miniature Linear Guide

2-3-5 Types of Lubrication

Grease

When a linear guide is well lubricated, the contact point between rail and rolling steel balls will be separated by 1 micro meter. Therefore, a good lubrication increases the service life of linear guide.

Clean room Lubrication

Suitable for low contamination environment.

Lubrication

General usage, ISO V32~68.

※If Special oil is required please contact *TBI MOTION*.

Table 2.3.3

Model	Lubrication amount (cc)	Model	Lubrication amount (cc)
TM07NN	0.3		
TM07NL	0.4		
TM09NN	0.4	TM09WN	0.4
TM09NL	0.6	TM09WL	0.6
TM012NN	0.9	TM012WN	0.9
TM012NL	1.3	TM012WL	1.3
TM015NN	1.4	TM015WN	1.4
TM015NL	2.0	TM015WL	2.0



2-3-6 Order Information

Customized Requirement :

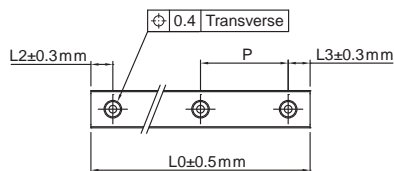

Table 2.3.4

Rail Length	Dimension			
	TM7	TM9	TM12	TM15
Pitch(mm)	15	20	25	40
Wide Pitch(mm)	—	30	40	40
L2, L3 min	3	4	4	4
L2, L3 max	10	20	20	35
Lmax	1300	1300	1300	1300

※If special dimension is required please contact *TBI MOTION*.

Height of Shoulder on Mounting Surface and Chamfer

Height of shoulder should be taken into consideration when installing a Linear Guide, if the block or rail is over-chamfered, the tip part has the possibility to effect the accuracy of Linear Guide, or if the height of shoulder is to high, it interferes the operation of block. Install the Linear Guide as suggested, the accuracy of Linear Guide can be maintained.

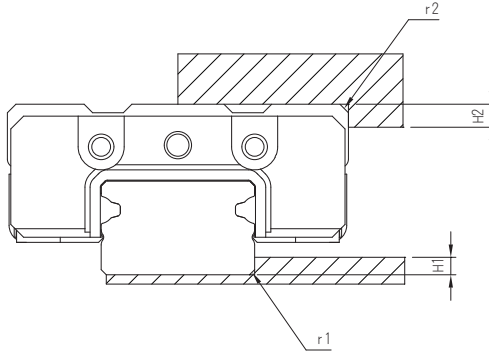

Table 2.3.5 Height of shoulder a chamfer

Model No.	Corner Radius of Mounting Surface r1	Corner Radius of Mounting Surface r2	Shoulder height on rail side H1	Shoulder height on rail side H2
TM07N	0.3	0.2	1	3
TM09N	0.3	0.3	1.7	3
TM12N	0.5	0.4	2.5	4
TM15N	0.5	0.5	2.5	5
TW09W	0.3	0.3	2.5	3
TW12W	0.5	0.5	3	4
TW15W	0.5	0.5	3	5

Table 2.3.6 Condition with Hexagonal Head Bolt

Model No.	Screw No.	Fasten Torque		
		Steel	Casting	Aluminum Alloy
TM07N	M2	57	39.2	29.4
TM09N	M3	186	127	98
TM12N	M3	186	127	98
TM15N	M3	186	127	98
TW09W	M3	186	127	98
TW12W	M4	392	274	206
TW15W	M4	392	274	206

TBI MOTION LINEAR GUIDE

2-3 TM Miniature Linear Guide

■ 2-3-7 Nominal Model Code of TM Type

Length of Block

Perform joint treatment when required lengths exceed 1300. Please contact TBI MOTION for detailed information.

T M 07 W L A - 2 - [] - 1000 - N A - Z0 - II K

① ② ③ ④ ⑤ ⑥ ⑦ ⑧ ⑨ ⑩ ⑪ ⑫ ⑬ ⑭

①	②	③	④
Nominal Model	Block Type	Dimension	Width of Rail
T	M : Mini X : Special	07, 09, 12, 15	N : Standard W : Wide
<i>(Drawing will be provided for special item in order to distinguish the height of the rail.)</i>			

⑤	⑥	⑦
Length of Block	Material of Block	Quantity of Block
N : Standard L : Long	S : Stainless steel A : Alloy steel	(Mark 1 when there is only 1 runner block)

⑧	⑨	⑩	⑪
Accessory Code	Length of Rail	Accuracy Grade	Material of Rail
□ : Standard (End seal + Side seal)	Unit : mm	N : Normal H : High P : Precision	S : Stainless steel A : High Carbon steel

⑫	⑬	⑭
Preload	Two Sets per Axis	Rail Special Machining
ZF : Slight Clearance Z0 : No Preload Z1 : Light Preload	(No need to be marked when there is only one rail) II	K : Tapped-Hole Rail X : Rail with Special Machining

※ No symbol required when no plating is need.

TM-N Series Specifications

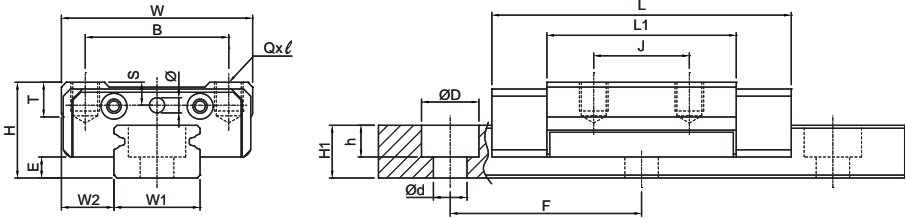

Model No.	Assembly (mm)			Rail(mm)							Block(mm)						
	H	W2	E	W	B	J	T	L	L1	Qxℓ	Ø	W1	H1	ØD	h	Ød	F
TM07NN	8	5	1.2	17	12	8	2.25	22.8	12.3	M2x2	1.3	7	4.7	4.2	2.3	2.4	15
TM07NL	8	5	1.2	17	12	13	2.25	30.8	20.3	M2x2	1.3	7	4.7	4.2	2.3	2.4	15
TM09NN	10	5.5	1.9	20	15	10	3.62	30.4	19.8	M3x3	1.3	9	5.5	6	3.3	3.5	20
TM09NL	10	5.5	1.9	20	15	16	3.62	40.7	30.1	M3x3	1.3	9	5.5	6	3.3	3.5	20
TM12NN	13	7.5	2.7	27	20	15	4.54	34.4	20.6	M3x3.5	1.3	12	7.5	6	4.5	3.5	25
TM12NL	13	7.5	2.7	27	20	20	4.54	46.9	33.1	M3x3.5	1.3	12	7.5	6	4.5	3.5	25
TM15NN	16	8.5	3.7	32	25	20	5.86	42.4	27	M3x5	1.3	15	9.5	6	4.5	3.5	40
TM15NL	16	8.5	3.7	32	25	25	5.86	59.4	44	M3x5	1.3	15	9.5	6	4.5	3.5	40

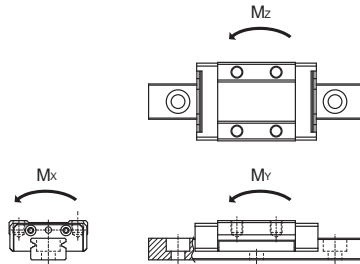

Model No.	Load Rating (kgf)		Static Permissible Moment					Weight	
			Mx(kgf-mm)	My(kgf-mm)		Mz(kgf-mm)		Rail (kg/m)	Rail (kg/m)
	C	Co		Single Block	Single Block	Double Block	Single Block		
TM07NN	144	204	745	232	3,234	232	3,234	0.005	0.21
TM07NL	220	374	1,367	849	7,261	849	7,261	0.009	
TM09NN	220	374	1,713	849	7,117	849	7,117	0.013	0.32
TM09NL	299	579	2,648	2,099	14,174	2,099	14,174	0.020	
TM12NN	381	536	3,269	1,094	12,391	1,094	12,391	0.024	0.61
TM12NL	555	919	5,604	3,437	26,857	3,437	26,857	0.039	
TM15NN	581	834	6,336	2,316	23,096	2,316	23,096	0.048	1
TM15NL	860	1,459	11,088	7,527	52,908	7,527	52,908	0.080	

TBI MOTION LINEAR GUIDE

2-1 The Types of TBI MOTION Linear Guide

TM-W Series Specifications

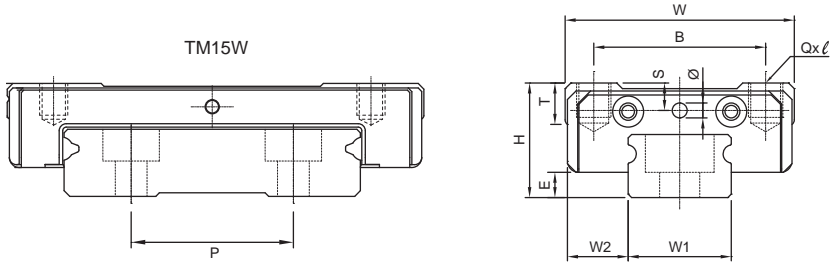

Model No.	Assembly (mm)			Rail(mm)							Block(mm)							
	H	W2	E	W	B	J	T	L	L1	Qxℓ	Ø	W1	H1	ØD	h	Ød	F	P
TM09WN	12	6	3	30	21	12	4	39.1	26.7	M3x3	1.3	18	7.3	6	4.5	3.5	30	
TM09WL	12	6	3	30	23	24	4	50.7	38.3	M3x3	1.3	18	7.3	6	4.5	3.5	30	
TM12WN	14	8	3.5	40	28	15	4.5	46.2	29	M3x3.5	1.3	24	8.5	8	4.5	4.5	40	
TM12WL	14	8	3.5	40	28	28	4.5	61.2	44	M3x3.5	1.3	24	8.5	8	4.5	4.5	40	
TM15WN	16	9	3.6	60	45	20	4.8	55.1	38.5	M4x4.5	1.3	42	9.5	8	4.5	4.5	40	23
TM15WL	16	9	3.6	60	45	35	4.8	74.2	57.6	M4x4.5	1.3	42	9.5	8	4.5	4.5	40	23

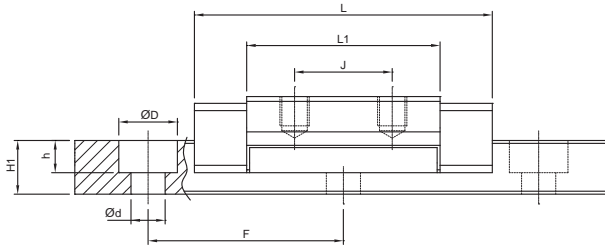

Model No.	Load Rating (kgf)		Static Permissible Moment					Weight	
			Mx(kgf-mm)	My(kgf-mm)		Mz(kgf-mm)		Rail (kg/m)	Rail (kg/m)
	C	Co		Single Block	Single Block	Double Block	Single Block		
TM09WN	208	368	4,645	1,621	12,205	1,621	12,205	0.03	0.97
TM09WL	260	509	7,123	3,905	23,411	3,905	23,411	0.043	
TM12WN	313	530	10,190	2,864	23,153	2,864	23,153	0.05	1.47
TM12WL	415	796	15,748	7,083	46,164	7,083	46,164	0.076	
TM15WN	517	856	26,387	5,459	42,543	5,459	42,543	0.116	2.85
TM15WL	686	1,283	41,779	14,144	87,256	14,144	87,256	0.175	

Memo

A large area of horizontal dashed lines for writing a memo, covering most of the page.

Memo

A large area of horizontal dashed lines for writing a memo, occupying most of the page.

A

Linear Guide

Ball Spline

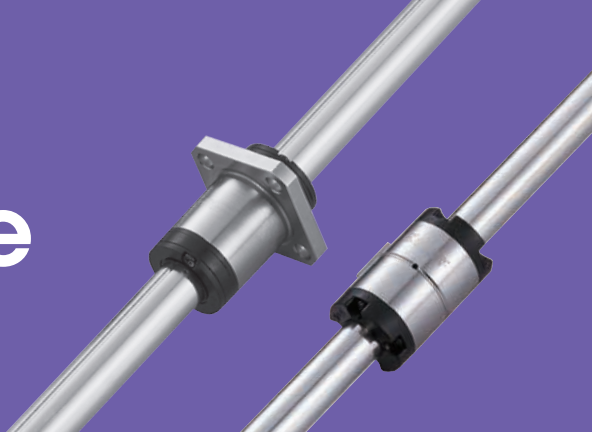

1-1 Structure and Benefits of TBI MOTION Ball Spline.....	B02
1-1-1 Basic Structure of TBI MOTION Ball Spline.....	B02
1-1-2 TBI MOTION Nut Design and Shaft Specifications.....	B02
1-1-3 Features of TBI MOTION Ball Spline	B03
1-1-4 TBI MOTION Ball Spline Type and Feature.....	B04
1-2 The Procedure of Select Ball Spline	B05
2-1 The Strength of Spline Shaft	B06
2-1-1 The Bending Load Applied on the Operating Ball Spline	B06
2-1-2 The Torque Applied on the Operating Ball Spline	B06
2-1-3 Both Bending Moment and Twisting Moment Applied Simultaneously on the spline shaft.....	B07
2-1-4 Rigidity of the Spline Shaft.....	B07
2-1-5 Deflection and Deflection Angle of the Spline Shaft	B08
2-1-6 Critical Speed of Spline Shaft	B10
2-1-7 Spline-Shaft Cross-Section.....	B11
2-2 Service Life Expectancy.....	B12
2-2-1 Nominal Service Life	B12
2-2-2 Calculating Nominal Service Life	B12
2-2-3 Calculating the Average Applied Load	B14
2-2-4 Equivalent Factor	B15
2-3 Calculating the Service Life	B16
2-4 Determining the Preload.....	B20
2-4-1 Clearance in the Rotational Direction.....	B20
2-4-2 Preload and Rigidity.....	B20
2-4-3 Operating Conditions and Determination of the Preload Level	B21
2-5 Accuracy	B22
2-5-1 Accuracy Grade.....	B22
2-5-2 Accuracy Specifications.....	B22
2-6 Lubrication	B24
2-7 Material and Surface Treatment	B24
2-8 Precautions of Ball Spline.....	B25
2-8-1 General Maintenance	B25
2-8-2 Lubrication.....	B25
2-8-3 Storage.....	B25
2-9 Mounting	B26
2-9-1 Tolerance on Support Unit.....	B26
2-9-2 Installation of Ball Spline	B26
2-9-3 Installation of Spline Nut.....	B27
3-1 Nominal Model Code of Ball Spline SL Series.....	B28
3-1-1 Nominal Model Code.....	B28
3-2 Nominal Model Code of Ball Spline SO Series	B36
3-2-1 Nominal Model Code.....	B36

ABOUT BALL SPLINE

1-1 Structure and Benefits of *TBI MOTION* Ball Spline

■ 1-1-1 Basic Structure of *TBI MOTION* Ball Spline

The design of TBI Ball spline is to utilize the friction through the contact of steel balls within in the Spline Nut and the grooves on the Spline Shaft. With TBI MOTION's unique 40° angular contact design which enables the Ball spline delivers high sensitivity and extreme high load carrying capacity. The concept is optimal for the application involve with high speed, vibration, impacts of loading and precise positioning requirements. Also when the Ball spline is used to function as linear bushing, the Ball spline provides ten times loading capacity than the linear bush on the like model but with a compact profile. Namely, Durability and reliability is the reason to choose TBI Ball spline in your application.

■ 1-1-2 *TBI MOTION* Nut Design and Shaft Specifications

TBI MOTION Spline Nut is available in four different designs : SLF (Flange design), SLT (Non-flange design), SOF (Cylindrical flange design), SOT (Round design), Point of contacts on the Spline shaft is provided in two grooves (180°) (SLF/SLT 6~20), (SOT/ SOF 8~25) and four grooves (70°) base on the diameter of the Spline shaft. Also TBI provides Hollow Spline shaft for alternative.

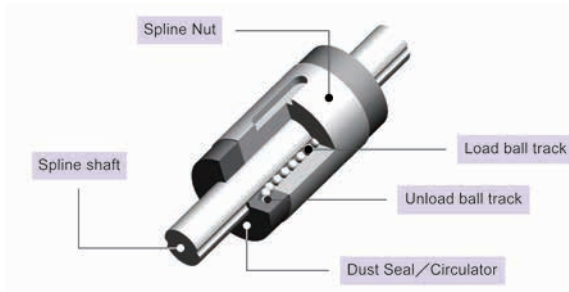

Fig 1.1.1

■ 1-1-3 Features of *TBI MOTION* Ball Spline

High Load-Carrying Capacity

Every groove on the TBI Spline shaft is precision ground to form a perfect 40° angular contact point. The concept of 40° contact design is to increase the load carrying capacity and rigidity to handle a greater moment load.

Zero Angular Clearance / Backlash

Grooves on the TBI Spline shaft is precision ground to form a perfect Gothic arch. The design eliminates clearance that could generate deflections, and therefore best suited for the applications that required high precision.

High Sensitivity

The unique TBI 40° angular contact is designed to operate with the minimum friction while the design performs high sensitivity and rigidity.

High Rigidity

A wide contact angle and an appropriate level of preload are combined to provide high rigidity and stiffness.



Mount-Simple on Design

TBI Ball Spline is low maintenance design, therefore, when removing the spline nut is necessary due to the ball retaining design the steel balls will not fall apart like the traditional nut design.

ABOUT BALL SPLINE

1-1 Structure and Benefits of *TBI MOTION* Ball Spline

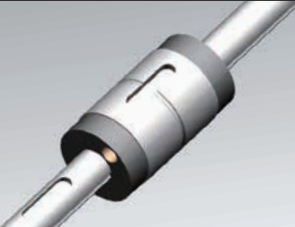
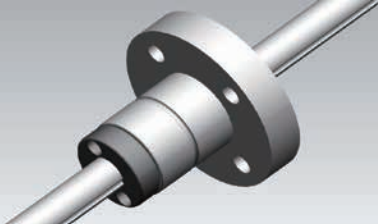
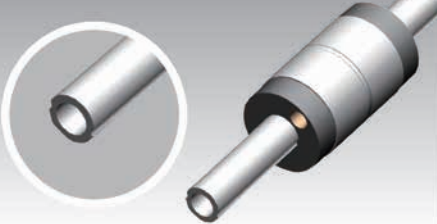
■ 1-1-4 *TBI MOTION* Ball Spline Type and Feature

Spline Nut	Spline Shaft
<p data-bbox="188 312 491 336">SLT, SOT Non-flanged Spline Nut</p>  <p data-bbox="115 576 560 751">SLT, SOT Spline nut is with a straight cylindrical shape without flange. The standard mode of mounting a cylindrical nut is by using a key. The cylindrical nut will have a keyway and separate key. A matching keyway must be bored into the housing or block that will be mounted on the cylinder nut. The type SLT, SOT is the most compact profile Spline nut in TBI Ball Spline product line.</p>	<p data-bbox="628 312 994 336">Standard Precision Spline Shaft (S-Type)</p>  <p data-bbox="585 576 1030 619">The Standard precision Spline shaft is precisely ground to reach high accuracy and smoothness.</p>
<p data-bbox="232 767 449 791">SLF, Flanged Spline Nut</p>  <p data-bbox="115 1031 560 1098">Flange nut is simpler to install because it only requires a rough bore and mounting holes drilled and tapped to secure the flange to the housing.</p>	<p data-bbox="678 767 944 791">Hollow Spline Shaft (H-Type)</p>  <p data-bbox="585 1031 1030 1118">Hollow Spline shaft is optional for the customer to choose for its application. Hollow Spline shaft is designed to reduce weight, accommodate pipes and ventilation.</p>
<p data-bbox="197 1134 486 1158">SOF, Square Flanged Spline Nut</p>  <p data-bbox="115 1398 560 1465">The nut with square flange is easy to be installed to the housing through mounting holes and will be applied to 3C industry and semiconductor industry.</p>	<p data-bbox="667 1134 956 1158">Custom Machining Spline Shaft</p>  <p data-bbox="585 1398 1030 1501">TBI has the capability to manufacture custom made Spline shaft by machining it to meet the requirements of special Spline Shaft shape. For example, a shaft with a bigger diameter on both ends or on the center of Spline shaft can be manufactured upon request.</p>

1-2 The Procedure of Select Ball Spline

Table 1.2.1

Steps	Description
1.Set the Operational conditions	<ul style="list-style-type: none"> ● Stroke Length : Ls ● Velocity : V ● The Applied Load : W ● Size ● Installation <ul style="list-style-type: none"> ● Operation environment ● Service life expectancy ● Accuracy ● Frequency of use (load cycle) ● Rigidity
2.Select a Type	<ul style="list-style-type: none"> ● Refer to Type, Shaft Spec to determine the your Ballspline.
3.Calculating the strength of Spline shaft	<ul style="list-style-type: none"> ● Spline Shaft Diameter ● Spline-Shaft Length ● End Fixity ● The permissible load of Ballspline ● The displacement under torque and deflection
4.Service expectancy	<div style="text-align: center;"> <pre> graph TD A[Calculating TBI Ball spline service life expectancy by using expectancy formula.] -- IF --> A A --> B{NO Required service life.} B -- NO --> C[] </pre> </div>
5.Determined the preload	<ul style="list-style-type: none"> ● Determined the permissible axial clearance/ backlash
6.Determine the Accuracy Grade	<ul style="list-style-type: none"> ● Accuracy Grades
7.Operational condition	<ul style="list-style-type: none"> ● Lubrication ● Lubrication methods ● Surface treatment ● Dust prevention methods
	Selected

2-1 The Strength of Spline Shaft

The Spline shaft is designed to absorb radial load and torque during operation. Therefore, the strength of Spline shaft must be taken into consideration when the Ball spline operates under extreme loading or torque.

2-1-1 The Bending Load Applied on the Operating Ball Spline

The maximum of bending moment (M) can be attributed to multi-factor such as the end fixity methods, length of Spline shaft, load capacity, etc. Equation (1) is equipped to help the user to obtain the ideal length of the Spline shaft in order to be the reference of obtaining the ideal strength of Ball spline.

$$M = \sigma \cdot Z \text{ and } Z = \frac{M}{\sigma} \dots(1)$$

M : Bending moment (N-mm)

σ : Shaft permissible bending stress (98 N/mm²)

Z : Shaft section modulus (mm³)

* Refer to Table 2.1.2, 2.1.3

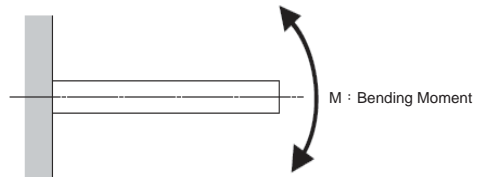

Fig 2.1.1

2-1-2 The Torque Applied on the Operating Ball Spline

The maximum torque applied on the Spline shaft can be calculated through maximum twisting moment (T). Equation (2) is equipped to help the user to obtain the ideal length of the Spline shaft.

$$T = \tau_a \cdot Z_p \text{ and } Z_p = \frac{T}{\tau_a} \dots(2)$$

T : Maximum twisting moment (N · mm)

τ_a : Shaft permissible twisting Stress (49 N/mm²)

Z_p : Shaft polar section modulus (mm³)

* Refer to Table 2.1.2, 2.1.3

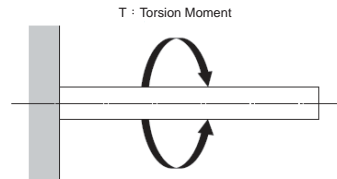

Fig 2.1.2

■ 2-1-3 Both Bending Moment and Twisting Moment Applied Simultaneously on the Spline Shaft

To calculate the figure for both bending (M) and twisting moments (T) applied on the Spline shaft via equation (3) and (4) get the equivalent bending moment (Me) and equivalent twisting moment (Te). Adopt the greater value from equation (3) and (4) to determine the ideal Spline-shaft length.

Equivalent Bending Moment

$$M_e = \frac{M + \sqrt{M^2 + T^2}}{2} = \frac{M}{2} \left\{ 1 + \sqrt{1 + \left(\frac{T}{M}\right)^2} \right\} \dots\dots(3)$$

$$M_e = \sigma \cdot Z$$

Equivalent Twisting Moment

$$T_e = \sqrt{M^2 + T^2} = M \cdot \sqrt{1 + \left(\frac{T}{M}\right)^2} \dots\dots(4)$$

$$T_e = \tau_a \cdot Z_p$$

■ 2-1-4 Rigidity of the Spline Shaft

The rigidity of the Spline Shaft is expressed in torsion angle caused by twisting moment. The twisting angle should be limited to no further than 0.25° per 1000 mm.

$$\theta = 57.3 \cdot \frac{T \times L}{G \times I_p} \dots\dots(5)$$

$$\text{Shaft Rigidity} = \text{Torsion Angle} / \text{Unit Length} = \frac{\theta \cdot \ell}{L} < \frac{1^\circ}{4}$$

- θ : Torsion Angle (°)
- L : Shaft Length (mm)
- G : Shear Elastic Modulus (7.9×10⁴N/mm²)
- ℓ : Unit Length (1000mm)
- I_p : Polar Moment of Inertia I_p (mm⁴)

※ Table 2.1.2, 2.1.3

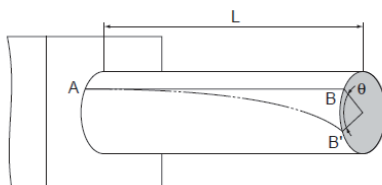

Fig 2.1.3

2-1 The Strength of Spline Shaft

■ 2-1-5 Deflection and Deflection Angle of the Spline Shaft

These should be calculated by using equations that satisfying the relevant operating conditions. Table 2.1.1 presents the operating conditions and the corresponding equations. Tables 2.1.2 & 2.1.3 presents the cross-section factors (Z) and cross-section secondary moments (I). Through the use of the Z, I values given in these tables, the strength and degree of displacement (deflection) of Ball spline model can be obtained.

Table 2.1.1 Deflection and Deflection-Angle Equation

End Fixity	Specification Conditions	Deflection Equation	Deflection-Angle Equation
Both Ends Free		$\delta_{\max} = \frac{Pl^3}{48EI}$	$i_1 = 0$ $i_2 = \frac{Pl^2}{16EI}$
Both Ends Fixed		$\delta_{\max} = \frac{Pl^3}{192EI}$	$i_1 = 0$ $i_2 = 0$
Both Ends Free		$\delta_{\max} = \frac{5Pl^4}{384EI}$	$i_2 = \frac{Pl^3}{24EI}$
Both Ends Fixed		$\delta_{\max} = \frac{Pl^4}{384EI}$	$i_2 = 0$

Table 2.1.1 Deflection and Deflection-Angle Equation

End Fixity	Specification Conditions	Deflection Equation	Deflection-Angle Equation
One Ends Fixed		$\delta_{\max} = \frac{Pl^3}{3EI}$	$i_1 = \frac{Pl^2}{2EI}$ $i_2 = 0$
One Ends Fixed		$\delta_{\max} = \frac{Pl^4}{8EI}$	$i_1 = \frac{Pl^3}{6EI}$ $i_2 = 0$
Both Ends Free		$\delta_{\max} = \frac{\sqrt{3} Mol^2}{216EI}$	$i_1 = \frac{Mol}{12EI}$ $i_2 = \frac{Mol}{24EI}$
Both Ends Fixed		$\delta_{\max} = \frac{Mol^2}{216EI}$	$i_1 = \frac{Mol}{16EI}$ $i_2 = 0$

δ_{\max} : Maximum Deflection (mm)

i_1 : Deflection Angle at a Loading Point (deg)

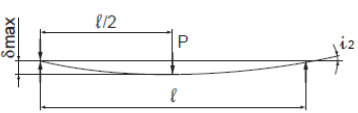
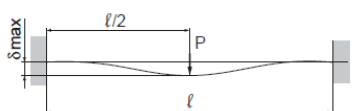
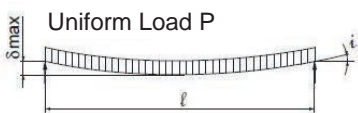
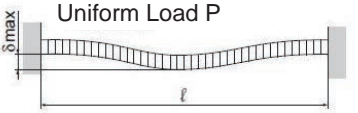
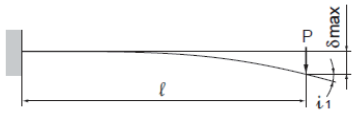
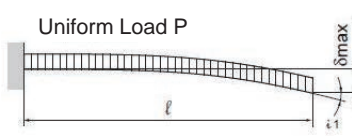
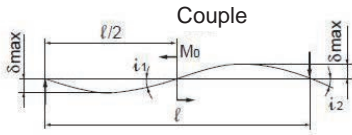
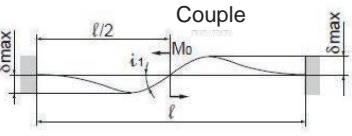
i_2 : Deflection Angle at a Supporting Point (deg)

M_0 : Moment (N-mm)

P : Concentrated Load (N)

p : Uniform Load (N/mm)

l : Span (mm)

I : Geometrical Moment of Inertia (mm⁴)

E : Longitudinal Elastic Modulus

($2.06/10^5$ N/mm²)

2-1 The Strength of Spline Shaft

■ 2-1-6 Critical Speed of Spline Shaft

When an operating Ball spline reaches critical speed, the mechanical resonance occurs, no further operation can be performed. Namely, to keep Ball Spline under ideal operational, the speed limit must be kept under monitor. Therefore, to set an ideal operational speed for safety factor must be settled as 80% of critical speed as shown on equation.

Critical Speed

$$N_c : \frac{60\lambda^2}{2\pi \times \ell_b^2} \times \sqrt{\frac{E \times 10^3 \times I}{\gamma \times A}} \times 0.8$$

N_c : Critical Shaft Speed (min⁻¹)

b : Center Distance (mm)

E : Young's Modulus (2.06 · 10⁵N/mm²)

I : Moment of Inertia of the Shaft (mm⁴)

$$I = \frac{\pi}{64} d_1^4$$

d_1 : Diameter (mm)

γ : Density (Specific Gravity) (7.85 · 10⁻⁶kg/mm³)

$$A = \frac{\pi}{4} d_1^2$$

d_1 : Diameter (mm)

A : Spline-Shaft Cross-Sectional Area (mm²)

λ : Installation-Method-Dependent Factor

(Fig 2.1.4) Fixed-Free $\lambda = 1.875$

(Fig 2.1.5) Supported-Supported $\lambda = 3.142$

(Fig 2.1.6) Fixed-Supported $\lambda = 3.927$

(Fig 2.1.7) Fixed-Fixed $\lambda = 4.73$

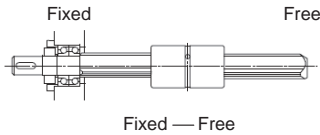

Fig 2.1.4

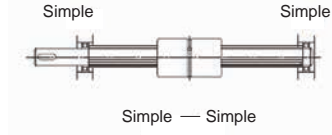

Fig 2.1.5

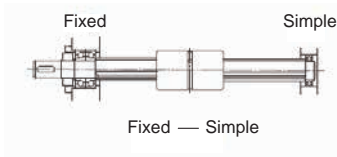

Fig 2.1.6

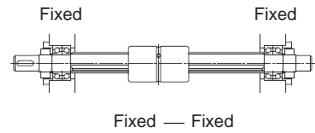

Fig 2.1.7

■ 2-1-7 Spline-Shaft Cross-Section

Table 2.1.2

Nominal Diameter		I (mm ⁴)	I _p (mm ⁴)	Z (mm ³)	Z _p (mm ³)
SL 006	Solid	63.49	119.23	18.58	39.74
	Hollow	62.70	117.33	18.32	39.22
SL 008	Solid	200.93	387.53	46.65	96.88
	Hollow	196.96	379.57	45.65	94.89
SL 010	Solid	490.25	933.29	86.61	186.66
	Hollow	477.68	908.16	86.10	181.63
SL 013	Solid	1400.81	2691.54	198.57	414.08
	Hollow	1282.96	2455.82	180.44	377.82
SL 016	Solid	3215.60	6242.70	378.39	780.34
	Hollow	3014.53	5840.57	353.25	730.07
SL 020	Solid	7851.80	15336.59	748.48	1533.66
	Hollow	7360.93	14354.84	699.39	1435.48
SL 025	Solid	18466.30	36932.60	1477.30	2954.61
	Hollow	15981.25	31962.50	1278.50	2557.00
SL 030	Solid	33122.31	77392.48	2579.75	4416.31
	Hollow	29905.32	70958.50	2365.28	3987.38
SL 032	Solid	50322.85	100645.70	3145.18	6290.36
	Hollow	36586.19	73172.38	2286.64	4573.27
SL 040	Solid	120667.43	241334.90	6033.37	12066.74
	Hollow	112813.45	225626.90	5640.67	11281.35
SL 050	Solid	297123.73	594247.50	11884.95	23769.90
	Hollow	274691.98	549384.00	10987.68	21975.36

I : Geometrical moment of inertia (mm⁴)

I_p : Polar moment of inertia (mm⁴)

Z : Section modulus (mm³)

Z_p : Polar section modulus (mm³)

Table 2.1.3

Nominal Diameter		I (mm ⁴)	I _p (mm ⁴)	Z (mm ³)	Z _p (mm ³)
SO 008	Solid	200.95	389.81	47.22	97.45
	Hollow	196.97	381.86	46.22	95.46
SO 010	Solid	490.68	956.77	93.22	191.35
	Hollow	478.11	931.64	90.71	186.33
SO 012	Solid	1017.67	1998.75	163.51	333.13
	Hollow	954.05	1871.52	152.91	311.92
SO 015	Solid	1678.22	3241.10	212.50	476.63
SO 020	Solid	5382.92	10422.07	553.75	1145.28
SO 025	Solid	12796.48	24659.94	1048.86	2182.30

I : Geometrical moment of inertia (mm⁴)

I_p : Polar moment of inertia (mm⁴)

Z : Section modulus (mm³)

Z_p : Polar section modulus (mm³)

2-2 Service Life Expectancy

2-2-1 Nominal Service Life

TBI define the nominal service life of Ball Spline as 90% of the average running distance before flaking within in the Ball Spline on the same manufacture cycle. Please note that the nominal life expectancy is only for reference use.

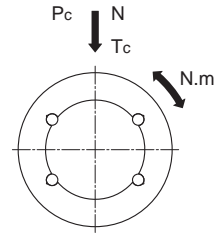

Fig 2.2.1

2-2-2 Calculating Nominal Service Life

The factors which influence the service life for Ball Splines can be attributed to three main aspects, the torque, radial load and moment. The influence of each aspect can be calculated through equations (7) to (10).

Under a Torque

$$L = \left(\frac{f_T \cdot f_C}{f_w} \cdot \frac{C_T}{T_c} \right)^3 \cdot 50 \dots (7)$$

Under a Radial Load

$$L = \left(\frac{f_T \cdot f_C}{f_w} \cdot \frac{C}{P_c} \right)^3 \cdot 50 \dots (8)$$

L : Nominal Service Life (km)

C_T : Basic Dynamic-Torque (N-m)

T_c : Calculated Torque Applied (N-m)

C : Basic Dynamic-Load Rating (N)

P_c : Radial Load (N)

f_T : Temperature (See Fig 2.2.2)

f_C : Contact (See Table 2.2.1)

f_w : Load Factor (See Table 2.2.2)

Under both a moment and radial load applied simultaneously

Calculate the service life from the sum of the radial load and the equivalent radial load.

Under both a torque and radial load applied simultaneously

In this case, calculate the equivalent radial load to determine service life by equation (9).

$$P_E = P_c + \frac{4 \cdot T_c \cdot 10^3}{i \cdot BCD \cdot \cos \alpha} \dots (9)$$

P_E : Equivalent radial Load (N)

cos α : Contact Angle

i : Number of Loaded Rows of Balls

BCD : Ball Center to Center Shaft Diameter (mm)
(See Table 3.1.1)

Under a moment on a spline nut or two closely attached to one another

Obtain the equivalent radial load using the equation,

and determine the service life by equation (10).

$$P_u = K \cdot M \dots (10)$$

P_u : Equivalent Radial Load (N)(Moment Applied)

K : Equivalent Factor (See Table 2.2.3)

M : Applied Moment (N-mm)

However, M should be within the range of the static permissible moment.

Calculating Nominal Service Life

Once the nominal life (L) is obtained, if the stroke length and the number of reciprocal operations are consistent, the service life in hours can be obtained by using the following equation.

$$L_h = \frac{L \cdot 10^3}{2 \cdot \ell_s \cdot n_1 \cdot 60}$$

L_h : Service Life in Hours (h)
 ℓ_s : Stroke Length (m)
 n_1 : Number of Reciprocal Operations per Minute (min^{-1})

Temperature Factor (f_T)

When the Ball Spline operates in an environment which the temperature reaches 100°C or higher, considering that the heat may adversely affect the operation of the Ball Spline. To avoid malfunction under extreme temperature, Fig 2.2.2 should be taken into consideration. In addition that the material of Ball Spline should be heat resistant and custom made when use under extreme environment.

※Please inform TBI sales for upgrading the material for the operation environment exceeds 80°C for the reason that the materials of seal and retainers should be upgraded to sustain the high-temperature.

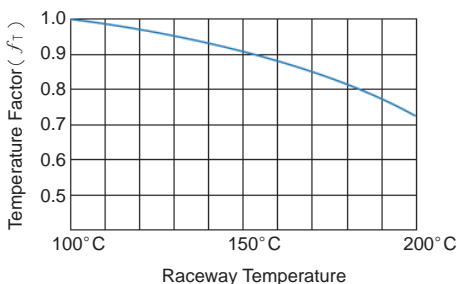

Fig 2.2.2 Temperature Factor (f_T)

Contact Factor (f_c)

When one or multiple Spline nuts are mounted on the Spline shaft closeley , their linear motion is affected by moments and mounting accuracy, resulting in nonuniform load distribution. When closely linked spline nuts are used, multiply the basic load rating (C or C_0) by one of the contact factors specifiedbelow.

※If a nonuniform load distribution is expected, as in large equipment, take the contact factor explained in Table 4 into account.

Table 2.2.1 Contact Factor (f_c)

No. of Spline nuts Linked	f_c
2	0.81
3	0.72
4	0.66
5	0.61
In Normal Use	1.0

Load Factor (f_w)

The operation of reciprocal machines is likely to cause vibration and impact. It is difficult to determine the rating of vibration, impact in the event of vibration, and repeated impact during high speed operation, and triggering and ceasing of operation. Therefore, when loads exerted on a linear-motion or operation velocity and vibration is extreme. Take the basic load rating (C or C_0) and multiply the figure shown in table 2.2.2

Table 2.2.2 Load Factor (f_w)

Vibration Impact	Velocity (V)	f_w
Minor	Minor velocity $V \leq 0.25$ m/s	1-1.2
Little	Low velocity $0.25 < V \leq 1.0$ m/s	1.2-1.5
Medium	Medium Velocity $1.0 < V \leq 2.0$ m/s	1.5-2.0
Heavy	High velocity $V > 2.0$ m/s	2.0-3.5

2-2 Service Life Expectancy

2-2-3 Calculating the Average Applied Load

The applied load fluctuates during the operation, for instance the applied load is different during the activities of an industrial robotic arm, industrial robot arm initiates with a workpiece and returns without one, the Ball Spline nut receives variable loads. The fluctuation of applied load influence the service life of Ball Spline, therefore the calculation of service life must take such fluctuation into consideration. When the service life of a Ball Spline with variable load is equal to the one with certain load then that certain load is called the Mean Load.

The Equation is as below

$$P_m = \sqrt[3]{\frac{1}{L} \cdot \sum_{n=1}^n (P_n^3 \cdot L_n)}$$

P_m : Mean Load (N)
 P_n : Fluctuating Load (N)
 L : Total Stroke
 L_n : Stroke under Load P_n (mm)

For Loads That Change Stepwise

$$P_m = \sqrt[3]{\frac{1}{L} (P_1^3 \cdot L_1 + P_2^3 \cdot L_2 \dots P_n^3 \cdot L_n)}$$

P_m : Mean Load (N)
 P_n : Fluctuating Load (N)
 L : Total Running Distance (mm)
 L_n : Running Distance Under Load P_n (mm)

For Loads That Change Monotonically

$$P_m = \sqrt[3]{\frac{1}{L} (P_{min}^3 \cdot L + P_{max}^3 \cdot L)}$$

P_{min} : Minimum Load (N)
 P_{max} : Maximum Load (N)

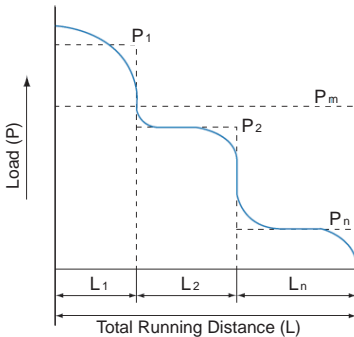

Fig 2.2.3

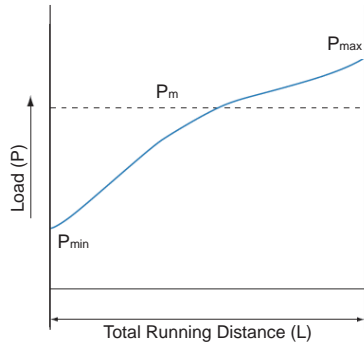

Fig 2.2.4

For Loads That Change Sinusoidal

(a) $P_m \cong 0.65 P_{max}$

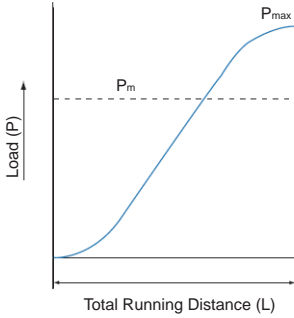

Fig 2.2.5

(b) $P_m \cong 0.75 P_{max}$

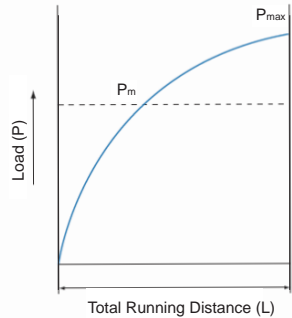

Fig 2.2.6

■ 2-2-4 Equivalent Factor

Table 2.2.3 Equivalent Factor

Model No.	Equivalent Factor : K	
	One Spline Nut	Two Spline Nuts
SL 06	0.577	0.065
SL 08	0.577	0.059
SL 10	0.418	0.047
SL 13	0.360	0.043
SL 16	0.229	0.033
SL 20	0.201	0.029
SL 25	0.154	0.023
SL 30	0.126	0.021
SL 32	0.114	0.019
SL 40	0.110	0.016
SL 50	0.109	0.013

Model No.	Equivalent Factor : K	
	One Spline Nut	Two Spline Nuts
SO 08	0.400	0.061
SO 10	0.308	0.052
SO 12	0.253	0.046
SO 15	0.219	0.040
SO 20	0.186	0.031
SO 25	0.154	0.026

2-3 Calculating the Service Life

Horizontal Application

A 300 mm long Ball Spline supported by two fixed nuts in a horizontal application, the load of the Spline falls vertically downward on the fixed side with 30 mm away from the center of ball spline with the gravity force of $W = 30$ kg. The figure is shown as Fig 2.3.1

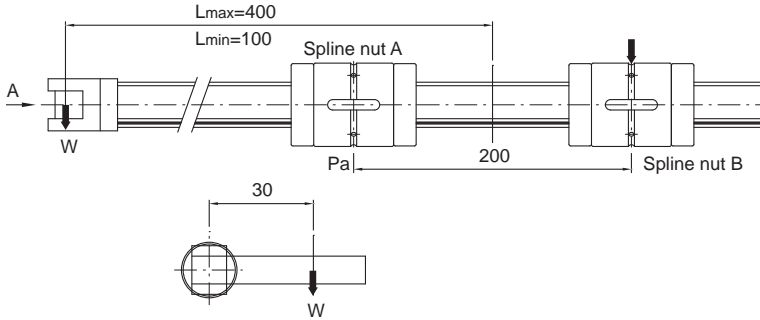

Fig 2.3.1

A. Calculates the Spline Shaft Strength

The presented structure of ball spline is an extended bridge, it is designed to absorb torque, therefore, the maximum bending load occurs on Spline nut A :

$$\text{Maximum Bending Moment } M = 30 \cdot 9.81 \cdot 400 = 117720 \text{ N}\cdot\text{mm}$$

$$\text{Maximum Torsion Moment } T = 30 \cdot 9.81 \cdot 30 = 8829 \text{ N}\cdot\text{mm}$$

For Ball Spline shafts subjected to the simultaneous application of torsion and bending loads, thus the calculation should include Equivalent Bending Moment, M_e and Equivalent Torsion Moment T_e :

$$M_e = \frac{M + \sqrt{M^2 + T^2}}{2} = 117885 \text{ N}\cdot\text{mm} \quad T_e = \sqrt{\frac{M^2 + T^2}{2}} = 118051 \text{ N}\cdot\text{mm}$$

$$T_e > M_e$$

$$\therefore T_e = \tau_a \cdot Z_p$$

$$\therefore Z_p = T_e / \tau_a = 118051 / 49 = 2409.2 \text{ mm}^3$$

According to figure of cross section showed on the spline (Table 2.1.3, 2.1.4), the minimum diameter, 25mm is required in order to gain enough strength of Ball Spline, therefore, SLF25 matches the requirement above thus choose SLF25.

B. Calculating the Mean Load

When the shaft extension reached $L_{\max} = 400$ mm, it reaches it' maxima load (P_{\max})

When it retrieved back to $L_{\min} = 100$ mm, it absorbed the minimum of load (P_{\min})

According to mechanics it allows us to acquire the maximum and minimum Radial Load of Nut A and nut B :

$$P_{A_{\max}} = 30 \cdot 9.81 \cdot (400+200)/200 = 882.9 \text{ N}$$

$$P_{B_{\max}} = 30 \cdot 9.81 \cdot 400/200 = 588.6 \text{ N}$$

$$P_{A_{\min}} = 30 \cdot 9.81 \cdot (100+200)/200 = 441.5 \text{ N}$$

$$P_{B_{\min}} = 30 \cdot 9.81 \cdot 100/200 = 147.2 \text{ N}$$

When the movement of Ball Spline occurs, the load on the spline is gradual and repeated, according to Fig 2.2.4 the equation of the load on ball spline is shown as :

$$P_{Am} = 1/3 (P_{A_{\min}} + 2P_{A_{\max}}) = 735.8 \text{ N}$$

$$P_{Bm} = 1/3 (P_{B_{\min}} + 2P_{B_{\max}}) = 441.5 \text{ N}$$

The nuts receive both torsion and bending load simultaneously, therefore assuming that the torsion distributes equally on the nuts. The equation for torsion is shown as T' :

$$T' = T/2 = 30 \cdot 9.81 \cdot 30/2 = 4414.5 \text{ N}\cdot\text{mm}$$

The equivalent factor P_e (B12, equation (9)) :

$$P_e = P_m + \frac{4 \cdot T'}{i \cdot dp \cdot \cos \alpha}$$

$$P_{AE} = 735.8 + \frac{4 \cdot 4414.5}{4 \cdot 27 \cdot \cos 50^\circ} = 990.2 \text{ N}$$

$$P_{BE} = 441.5 + \frac{4 \cdot 4414.5}{4 \cdot 27 \cdot \cos 50^\circ} = 695.9 \text{ N}$$

C. Service Life Ball Spline

$$\text{Nut A life } L_A = \left(\frac{f_T \cdot f_C}{f_w} \cdot \frac{C}{P_{AE}} \right)^3 \cdot 50 = 14518 \text{ km}$$

$$\text{Nut B life } L_B = \left(\frac{f_T \cdot f_C}{f_w} \cdot \frac{C}{P_{BE}} \right)^3 \cdot 50 = 41829 \text{ km}$$

Factors
 f_T : Temperature = 1
 f_C : Friction = 1
 f_w : Load = 1.5
 C : Coa = 9835 N

The service life of Ball Spline correlates with nut A and the service life is 14518 by estimate.

Vertical Application

A 1200 mm long ball spline with stroke of 1000 mm is mounted on a working platform supported by two fixed nuts on both end. The geometry is shown as Fig 2.3.2

The point of drive force F is $X_1 = 50$ mm, from the center of Ball Spline, the weight platform W_1 is 27 kg, the center of the weight is $X_2 = 300$ mm, away from the center of ball spline, the working cycle of platform is a carriage of $W_2 = 5$ kg, with a downward movement for 5 sec and holds for 10 sec, then elevates for 5 sec and holds for 10 sec to unload the carriage repeatedly. The center of gravity of carriage is $X_3 = 500$ mm, from the center of ball spline, the travelling of velocity is shown as Fig 2.3.2

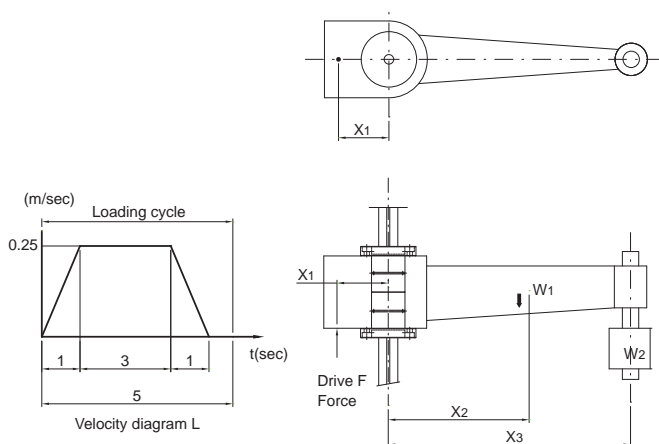

Fig 2.3.2

2-3 Calculating the Service Life

A. Analysis on Different Stage of Exertion

Inertial force occurs when a platform is in working modes, drive force is the source of the inertial force.

Inertial force of a m/s^2 in accelerated ascent and decelerated decent : $F = W \cdot (9.81+a)$

Inertial force of Constant velocity in acceleration and deceleration : $F = W \cdot (9.81)$

Inertial force of a m/s^2 in accelerated decent and decelerated ascent : $F = W \cdot (9.81-a)$

Below are the equations of the bending force absorb by the nuts during acceleration, constant velocity, deceleration while ball ascent and decent.

(1) Without carriage (Acceleration while decent)

$$M_{da} = W_1 \cdot (9.81-a) \cdot 300 + W_1 \cdot (9.81-a) \cdot 50 = 90342 \text{ N-mm}$$

(2) Without carriage (Constant velocity while decent)

$$M_{dc} = W_1 \cdot (9.81) \cdot 300 + W_1 \cdot (9.81) \cdot 50 = 92704.5 \text{ N-mm}$$

(3) Without carriage (Deceleration while decent)

$$M_{dd} = W_1 \cdot (9.81+a) \cdot 300 + W_1 \cdot (9.81+a) \cdot 50 = 95067 \text{ N-mm}$$

(4) With carriage (Acceleration while ascent)

$$M_{aa} = W_1 \cdot (9.81+a) \cdot 300 + W_1 \cdot (9.81+a) \cdot 50 + W_2 \cdot (9.81+a) \cdot 500 + W_2 \cdot (9.81+a) \cdot 50 = 122732 \text{ N-mm}$$

(5) With carriage (Constant velocity while ascent)

$$M_{ac} = W_1 \cdot (9.81) \cdot 300 + W_1 \cdot (9.81) \cdot 50 + W_2 \cdot (9.81) \cdot 500 + W_2 \cdot (9.81) \cdot 50 = 119682 \text{ N-mm}$$

(6) With carriage (Deceleration while ascent)

$$M_{ad} = W_1 \cdot (9.81-a) \cdot 300 + W_1 \cdot (9.81-a) \cdot 50 + W_2 \cdot (9.81-a) \cdot 500 + W_2 \cdot (9.81-a) \cdot 50 = 116632 \text{ N-mm}$$

B. The Calculation of Spline Strength

The presented structure of ball spline is supported by two fixed nuts on both ends with an bridge of absorbing bending in the middle. it designed to absorb torque. According to mechanics the Maximum bending load occurs on the supporting end. The Maximum Bending Moment should occur at the end of acceleration.

Maximum Bending Moment $M = 122732 \text{ N-mm}$

$$\therefore Z = M/\sigma_a = 122732/98 = 1252.4 \text{ mm}^3$$

According to figure of cross section showed on the spline, the minimum diameter 25 mm is required in order to gain enough of strength for Ball Spline, therefore SLF25 matches the requirement above thus choose SLF25.

C. Calculating the Mean Load

The nuts and spline mainly affect by the force of bending, therefore converting the force of bending into rail load by using (B12, equation(10)).

$$P_n = K \cdot M$$

According to Table 2.2.3, when joint two SLF25 nuts, The equivalent factor $K = 0.023$

$$P_{da} = 0.023 \cdot 90342 = 2078 \text{ N}$$

$$P_{aa} = 0.023 \cdot 122732 = 2822.8 \text{ N}$$

$$P_{dc} = 0.023 \cdot 92704.5 = 2132.2 \text{ N}$$

$$P_{ac} = 0.023 \cdot 119682 = 2752.7 \text{ N}$$

$$P_{dd} = 0.023 \cdot 95067 = 2186.5 \text{ N}$$

$$P_{ad} = 0.023 \cdot 116632 = 2682.5 \text{ N}$$

The average load in every time period can be calculate as P_m :

$$P_m = \sqrt[3]{\frac{1}{L} \cdot \sum_{n=1}^n (P_n^3 \cdot L_n)}$$

P_m : Average Load (N)
 P_n : Load in variable (N)
 L : Total service distances (mm)
 L_n : P_n Service distances (mm) under loading

$$P_m = \sqrt[3]{\frac{1}{1000} \{125 \cdot 2078^3 + 750 \cdot (2132.2)^3 + 125 \cdot (2822.8)^3 + 750 \cdot (2752.7)^3 + 125 \cdot (2682.5)^3\}}$$

$$= 2481.6 \text{ N}$$

D. Analysis of Ball Spline Service Life

$$\text{Service Life } L_A = \left(\frac{f_T \cdot f_C}{f_W} \cdot \frac{C}{P_m} \right)^3 \cdot 50 = 922 \text{ km}$$

$$f_T : \text{Temperature} = 1$$

$$f_C : \text{Friction} = 1$$

$$f_W : \text{Load} = 1.5$$

$$C : \text{Coa} = 9835 \text{ N}$$

2-4 Determining the Preload

The preload, a significant factor that influence the accuracy, load capacity and rigidity of Ball Spline during operation. Therefore, it is very important to determine the most appropriate size of the clearance for your requirements. The size of the clearance is standardized for each type, enabling the one best-suited for operating conditions to be selected.

■ 2-4-1 Clearance in the Rotational Direction

With the Ball Spline, the sum of clearances in the circumferential direction is standardized as the clearance in the rotational direction. Clearance in the Rotational Direction. (BCD)

■ 2-4-2 Preload and Rigidity

The preload is the load applied to balls prior to use for the purposes of eliminating angular backlash (clearance in the rotational direction) and improving rigidity. The application of a preload can eliminate angular backlash in the Ball Spline in accordance with the level of applied preload, and can improve rigidity. Fig 2.4.2 shows the amount of displacement in the rotational direction when a rotational torque is applied. As shown in Fig 2.4.2, the effect of pre-loading continues until the torque becomes

Fig 2.4.2 2.8 times greater than the preload applied. Compared with a setting without a preload, the displacement at the same rotational torque is half of the one with a preload and the rigidity is twice as great.

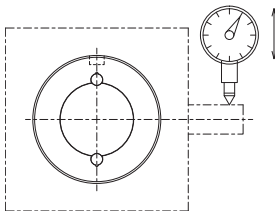

Fig 2.4.1

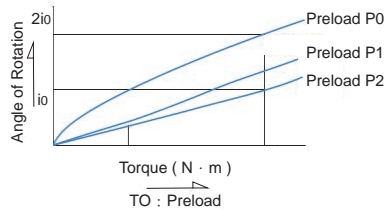

Fig 2.4.2

■ 2-4-3 Operating Conditions and Determination of the Preload Level

Table 2.4.1 presents guidelines for determining the appropriate clearance in the rotational direction for different operating environment. The rotational clearance of the Ball Spline significantly affects the accuracy and rigidity of the Spline nut. Therefore, it is critical to select the clearance best suited to the intended uses of the Ball Spline. Normally, the Ball Spline is preloaded. When it is subjected to repeated swiveling and reciprocal linear motion, the system receives heavy vibration and impact. In such an environment, preload prolongs the service life and improves accuracy.

Table 2.4.1 Guidelines for Determining an Appropriate Ball Spline Clearance according the Rotational Direction.

Clearance in the Rotational Direction	Preload	Operating conditions	Applications
	Medium Preload P2	<ul style="list-style-type: none"> High rigidity is required. Vibration and impact are severe. The moment load must be borne by a single spline nut. 	<ul style="list-style-type: none"> Construction-work-vehicle steering shaft. Spot-welding-machine shaft. Automatic-lathe-tool rest indexing shaft.
	Light Preload P1	<ul style="list-style-type: none"> Hanging loads and moments are applied. High position accuracy is required. Alternate loads are applied. 	<ul style="list-style-type: none"> Industrial robot arm Various automatic loaders. Automatic-painting-machine guideshaft. Electric-discharge-machine spindle. Press die-set guideshaft. Drilling-machine spindle.
	No Preload P0	<ul style="list-style-type: none"> Smooth movement should be achieved with only a low magnitude of force. Torque is continually applied in a given direction. 	<ul style="list-style-type: none"> Various measuring instruments. Automatic drafting machine. Shape-measuring instrument. Dynamometer. Wirewinder. Automatic arccutter. Honing-machine spindle. Automatic packing machine.

Table 2.4.2

Preload Nominal Diameter					No Preload P0	Slight Preload P1	Medium Preload P2
6	8	10	12	13	-2 ~ +1	-6 ~ -2	-
15		16	20		-2 ~ +1	-6 ~ -2	-9 ~ -5
25			30		-3 ~ +2	-10 ~ -4	-14 ~ -8
40		50			-4 ~ +2	-16 ~ -8	-22 ~ -14

TECHNICAL INFORMATION

2-5 Accuracy

2-5-1 Accuracy Grade

The accuracy of the Ball Spline is determined by the spline-nut and thus divided into three accuracy grades of Normal(N), High(H), and Precision(P).

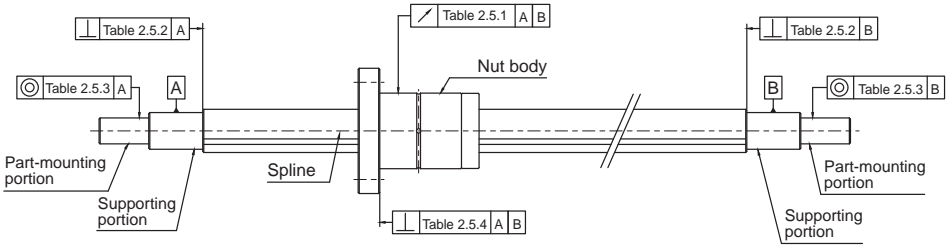

2-5-2 Accuracy Specifications

Tables 2.5.2~2.5.5 indicate the tolerance of callout of the Ball Spline.

Table 2.5.1 The tolerance of Spline Nut on the Support Unit

Unit : μm

Nominal Diameter (mm)		6, 8			10			12, 13, 15, 16, 20			25, 30			40, 50		
		N	H	P	N	H	P	N	H	P	N	H	P	N	H	P
Above	Below															
-	200	72	46	26	59	36	20	56	34	18	53	32	18	53	32	16
200	315	133	89	57	83	54	32	71	45	25	58	39	21	58	36	19
315	400	185	126	82	103	68	41	83	53	31	70	44	25	63	39	21
400	500	236	163	108	123	82	51	95	62	38	78	50	29	68	43	24
500	630	-	-	-	151	102	65	112	75	46	88	57	34	74	47	27
630	800	-	-	-	190	130	85	137	92	58	103	68	42	84	54	32
800	1000	-	-	-	-	-	-	170	115	75	124	83	52	97	63	38
1000	1250	-	-	-	-	-	-	-	-	-	151	102	65	114	76	47

Table 2.5.2 The Maximum Perpendicularity of Spline Shaft End on the Journal Ends

Unit : μm

Accuracy					Normal (N)	High (H)	Precision (P)
6	8	10			22	9	6
12	13	15	16	20	27	11	8
25		30			33	13	9
40		50			39	16	11

Table 2.5.3 The Maximum Radial Call Out on the Attach Surface

Unit : μm

Accuracy					Normal (N)	High (H)	Precision (P)
6	8				33	14	8
10					41	17	10
12	13	15	16	20	46	19	12
25		30			53	22	13
40		50			62	25	15

Table 2.5.4 The Perpendicularity of Flange on the Attach Surface

Unit : μm

Accuracy					Normal (N)	High (H)	Precision (P)
6	8				17	11	8
10	12	13			33	13	9
15	16	20	25	30	30	16	11
40		50			46	19	13

Table 2.5.5 The Accuracy Level on the Effective Length Accuracy

Unit : μm

Accuracy	Normal (N)	High (H)	Precision (P)
Permissible	33	13	6

※ Applies to any effective stroke of 100mm Ball Spline shaft.

2-6 Lubrication

The spline nut is prelubricated prior to shipment for immediate use and the maintenance period is varied according to the operating conditions. TBI suggested that under normal operation condition please lubricate your TBI Ball Spline after 100 Km (6-12 months) of operation. Apply lubricant within the nut body or on the groove of Spline shaft.

2-7 Material and Surface Treatment

Provides customize material and surface treatment in order to meet extreme operation condition. Please contact service window for customized surface treatment and material.

2-8 Precautions of Ball Spline

■ 2-8-1 General Maintenance

- (1) Disassemble ball spline without supervise of certified engineer will cause malfunction of the ball spline.
- (2) Gravity causes the spline nut slides when lining the ball spline, handle with care.
- (3) Do not hammer, free fall the ball spline, such action will damaging the ball spline and might hinder the performance of ball spline.
- (4) Prevent debris, scraps from intervene the ball spline cause it will decrease the performance to ball spline or lead to malfunction.
- (5) Prevent the ball spline operates under extreme condition. Contact service window when the TBI ball spline is intend to use under extreme condition.
- (6) Coolant might cause malfunction on the ball spline, please consult certified engineer for the use of coolant.
- (7) Clean attached debris and scraps before relubrication.
- (8) Please consult certified engineer when the ball spline is designed to operate under frequent vibration, vacuum, extreme high and low temperature condition.
- (9) Please consult certified engineer when mounting a through hole on the flanged ball spline.

■ 2-8-2 Lubrication

- (1) Remove anti-dust oil before seal the ball spline with grease.
- (2) Prevent mixing of different kind of grease, it will cause unexpected chemical deform.
- (3) Please contact certified engineer for consulting the use of grease when the ball spline is designed to operate under frequent vibration, vacuum, extreme high and low temperature condition.
- (4) Please consult certified engineer for the use of non-certified grease.
- (5) When using motor oil to serve the purpose of lubrication, it might cause performance declining due to the improper installation, please consult certified engineer.

■ 2-8-3 Storage

Prevent extreme temperature and humidity while storing the ball spline, please use certified seal and storage in a horizontal position.

2-9 Mounting

■ 2-9-1 Tolerance on Support Unit

Ball spline nut and its support unit is bore to minimize the clearance. If high accuracy is not required, then a clearance fit can be used.

Table 2.9.1

Condition	Tolerance within Support Unit
General Operation Condition	H7
Operation Under Minimize of Axial Clearance	J6

■ 2-9-2 Installation of Ball Spline

The installation of the Ball Spline is shown as Fig 2.9.2. Though the strength of mounting is not strictly required, but it has to be certain that the spline shaft firmly fixed on the support unit.

Table 2.9.2 Sample of Spline-Nut Assembly

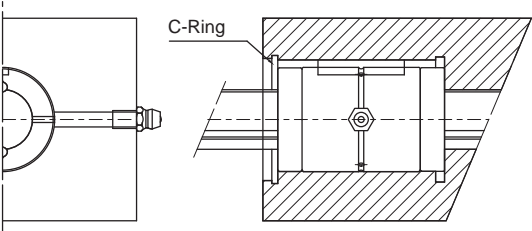
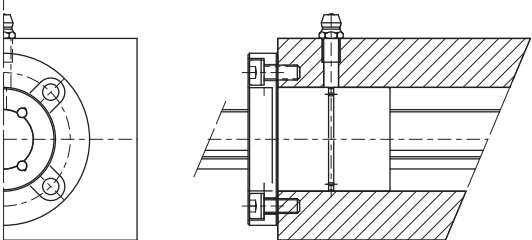
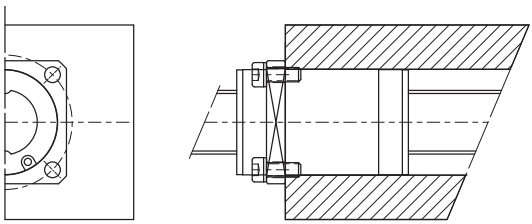
<p>SLT,SOT (C-Ring Type)</p>	
<p>SLF (Flange One- Stage Type)</p>	
<p>SOF (Flange One- Stage Type)</p>	

2-9 Mounting

■ 2-9-3 Installation of Spline Nut

When installing a spline nut into the spline shaft, use a jig shown in fig 2.9.1 to insert the spline with care.

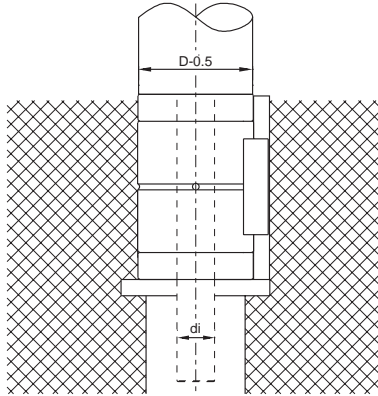

Fig 2.9.1

Table 2.9.3 Specifications of the jig

Unit : mm

Model	Nominal Diameter	6	8	10	13	16	20	25	30	40	50
SL	di	5.0	7.0	8.5	11.5	14.5	18.5	23	28	37.5	46.5
Model	Nominal Diameter	-	8	10	12	15	20	25	-	-	-
SO	di	-	7.0	8.5	10.5	11	16	20.5	-	-	-

TBI MOTION BALL SPLINE

3-1 Nominal Model Code of Ball Spline SL Series

■ 3-1-1 Nominal Model Code

TBI MOTION Ball Spline is classified into interchangeable and non-interchangeable types. Their dimensions are the same; the only difference between two types is that for non-interchangeable series, **TBI MOTION** will finish every process in the production line to meet customers' demands. Interchangeable nuts and shafts can be freely exchanged and the standard preload is P0. Customers could adjust the preload by changing the steel balls inside of the nut by themselves. It is very convenient for customers to have **TBI MOTION** Ball Spline in inventory and make the preload and end machining by themselves. **TBI MOTION** is proud of internal quality control process which is under strict international regulation.

Non-interchangeable Type Code :

SLF 006 T2 N N S - 500 - P0 - B2 + N3 N3

①
②
③
④
⑤
⑥
⑦
⑧
⑨
⑩
⑪

①	②	③	④
Spline Nut	Nominal Diameter	Groove	Flange Type
SLF : Flanged SLT : Cylindrical	Unit : mm	T2 : 2 Rows T4 : 4 Rows	N : Round (No Symbol When It is Without the Flange)

⑤	⑥	⑦
Accuracy Grade of Spline Shaft	Spline Shaft Type	Overall Length of Spline Shaft
N : Normal H : High P : Precision	S : Solid H : Hollow	Unit : mm

⑧	⑨	⑩
Preload Value	Number of Spline Nut	Nut Surface Treatment
P0 : No preload P1 : Light preload P2 : Medium preload	(Leave blank if only one nut is required) Ex : Install two spline nuts on a shaft.B2	S : Standard B1 : Black Oxidation N1 : Hard Chrome Plating P : Phosphating N3 : Nickel Plating N4 : Raydent N5 : Chrome Plating

⑪
Shaft Surface Treatment
S : Standard B1 : Black Oxidation N1 : Hard Chrome Plating P : Phosphating N3 : Nickel Plating N4 : Raydent N5 : Chrome Plating

※No symbol required when plating is not needed.

Nominal Model Code for Interchangeable SL Type

Interchangeable Type of Spline Nut :

SLF 006 T2 N + N3

① ② ③ ④ ⑤

① Spline Nut	② Nominal Diameter	③ Groove	④ Flange Type
SLF : Flanged	Unit : mm	T2 : 2 Rows	N : Round (No Symbol When It is Without the Flange)
SLT : Cylindrical		T4 : 4 Rows	

⑤

Nut Surface Treatment
S : Standard
B1 : Black Oxidation
N1 : Hard Chrome Plating
P : Phosphating
N3 : Nickel Plating
N4 : Raydent
N5 : Chrome Plating

Interchangeable Type of Spline Shaft :

SC 006 T2 N S - 500 + N3

① ② ③ ④ ⑤ ⑥ ⑦

① Nominal Model Code	② Nominal Diameter	③ Groove	④ Accuracy Grade of Spline Shaft
	Unit : mm	T2 : 2 Rows	N : Normal
		T4 : 4 Rows	

⑤

Spline Shaft Type
S : Solid
H : Hollow

⑥

Overall Length of Spline Shaft
Unit : mm

⑦

Nut Surface Treatment
S : Standard
B1 : Black Oxidation
N1 : Hard Chrome Plating
P : Phosphating
N3 : Nickel Plating
N4 : Raydent
N5 : Chrome Plating

TBI MOTION BALL SPLINE

3-1 Nominal Model Code of Ball Spline SL Series

SLF, SLT Spline Shaft Cross-Sectional Shape

Table 3.1.1, 3.1.2 indicates the cross-section of spline shaft. When the shaft end is round pillar type the minor diameter must not be greater than the diameter of groove ridge.

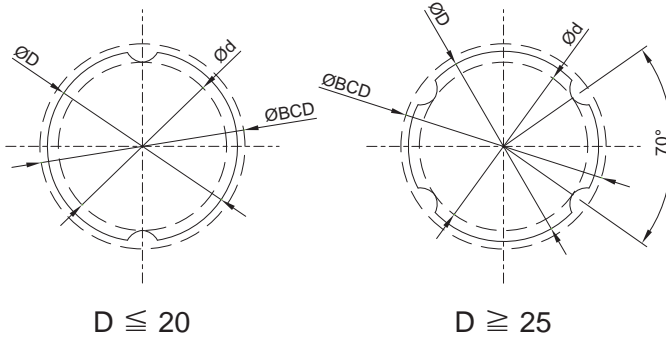

Solid Spline Shaft

Table 3.1.1 Solid Spline Shaft Cross-Sectional Shape

Unit : mm

Stats	Nominal Diameter									
	6	8	10	13	16	20	25	30	40	50
Inner Diameter Ød	5.25	7.27	8.97	11.82	14.72	18.63	23.43	28.53	37.3	47.05
Outer Diameter ØD h7	6	8	10	13	16	20	25	30	40	50
Mass (kg/m)	0.22	0.39	0.6	1.03	1.56	2.44	3.8	5.49	9.69	15.19
Ball Center ØBCD	6.75	8.77	11.35	14.6	17.5	21.8	27	32.1	43.65	54.2
Tolerance µm	0 -15	0 -15	0 -18	0 -18	0 -18	0 -21	0 -21	0 -25	0 -25	0 -30

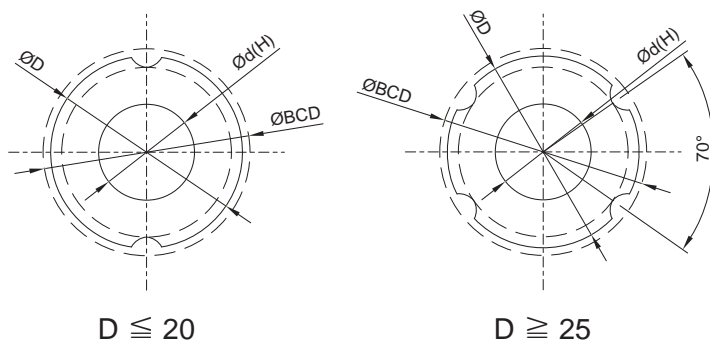

Hollow Spline Shaft

Table 3.1.1 Solid Spline Shaft Cross-Sectional Shape

Unit : mm

Nominal Diameter	6	8	10	13	16	20	25	30	40	50
Stats										
Inner Diameter $\text{Ø}d$	2	3	4	7	8	10	15	16	20	26
Outer Diameter $\text{Ø}D h7$	6	8	10	13	16	20	25	30	40	50
Mass (kg/m)	0.177	0.33	0.506	0.872	1.25	1.82	2.92	3.93	6.75	11.4
Ball Center $\text{Ø}BCD$	6.75	8.77	11.35	14.6	17.5	21.8	27	32.1	43.65	54.2
Tolerance μm	0 -15	0 -15	0 -18	0 -18	0 -18	0 -21	0 -21	0 -25	0 -25	0 -30

TBI MOTION BALL SPLINE

3-1 Nominal Model Code of Ball Spline SLF Series

SLF Series Specifications

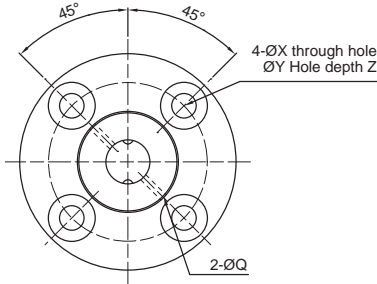

【Two Starts】 Type : 06、10、13

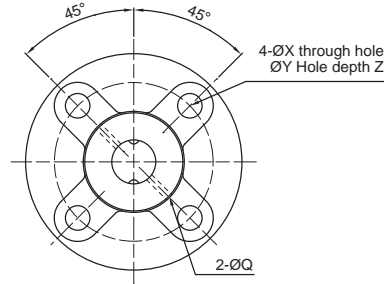

【Two Starts】 Type : 08、16、20

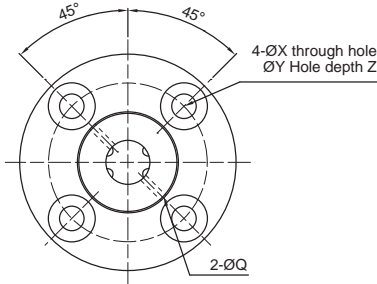

【Four Starts】 Type : 40、50

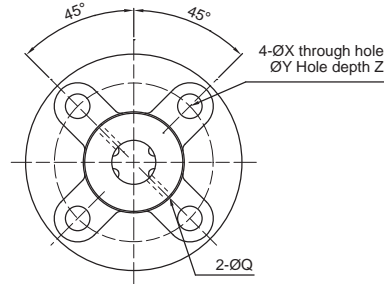

【Four Starts】 Type : 25、30

Model No.	Diameter		Spline Nut Dimension									
	d	Row	D	L	A	B	F	Oil Hole	W	Mounting Hole		
	h7							Q		X	Y	Z
SLF006	6	2	14	25	30	6	7.5	1	22	3.4	6.5	3.5
SLF008	8	2	16	27	32	8	7.5	1.5	24	3.4	6.5	4.5
SLF010	10	2	21	33	42	9	10.5	1.5	32	4.5	8	4
SLF013	13	2	24	36	44	9	11	1.5	33	4.5	8	4.5
SLF016	16	2	31	50	51	10	18	2	40	4.5	8	6
SLF020	20	2	35	56	58	10	18	2	45	5.5	9.5	5.4
SLF025	25	4	42	71	65	13	26.5	3	52	5.5	9.5	8
SLF030	30	4	47	80	75	13	30	3	60	6.6	11	8
SLF040	40	4	64	100	100	18	36	4	82	9	14	12
SLF050	50	4	80	125	124	20	46.5	4	102	11	17.5	12

B

Ball Spline

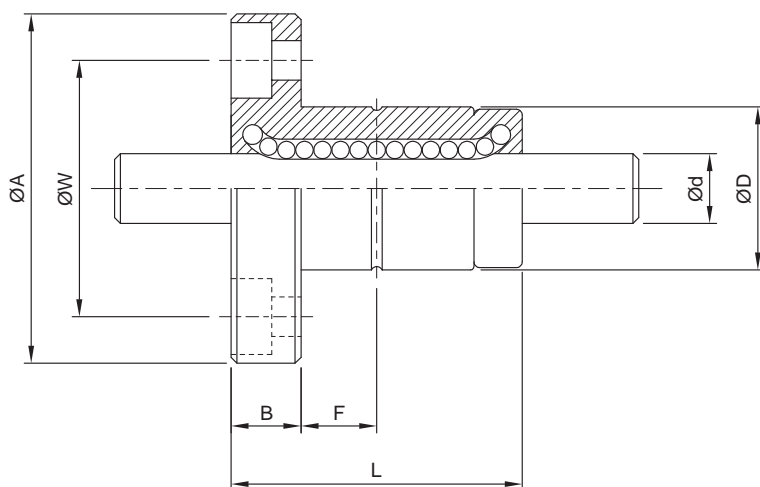

Model No.	Basic Load Rating		Basic Torsion		Static Permissible Moment		Mass	
	C	C ₀	C _T	C _{0T}	M _{A1}	M _{A2}	Spline Nut	Spline Shaft
	kgf	kgf	kgf · m	kgf · m	kgf · m	kgf · m	g	kg/m
SLF006	137	225	0.46	0.76	0.39	3.48	36.7	0.22
SLF008	137	225	0.60	0.99	0.39	3.82	47	0.39
SLF010	285	397	1.62	2.25	0.95	8.53	100	0.60
SLF013	396	540	2.89	3.94	1.50	12.46	117	1.03
SLF016	545	849	4.77	7.43	3.71	26.09	226	1.56
SLF020	724	1109	7.90	12.09	5.53	38.00	303	2.44
SLF025	1003	1593	21.99	43.01	10.35	68.59	458	3.80
SLF030	1160	1980	30.26	62.93	15.68	93.27	633	5.49
SLF040	2972	4033	105.37	176.05	36.59	246.34	1430	9.69
SLF050	4086	5615	179.89	304.35	51.58	428.72	2756	15.19

TBI MOTION BALL SPLINE

3-1 Nominal Model Code of Ball Spline SL Series

SLT Series Specifications

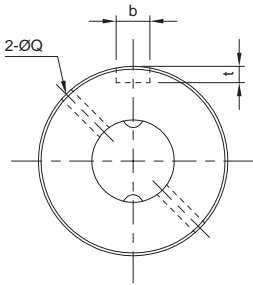

< Two row >

Shaft diameter $d \leq 20$

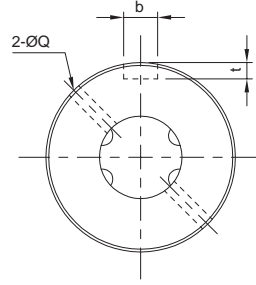

< Four row >

Shaft diameter $d \geq 25$

Model No.	Diameter		Row	Spline Nut Dimension				Keyway Dimensions		
	d	h7		D	L	S	L1	Oil Hole	b	t
	Q							H8	+0.05 ~0	
SLT006	6		2	14	25	16.7	10.5	1	2.5	1.2
SLT008	8		2	16	27	15.7	10.5	1.5	2.5	1.2
SLT010	10		2	21	33	20	13	1.5	3	1.5
SLT013	13		2	24	36	23	15	1.5	3	1.5
SLT016	16		2	31	50	34	17.5	2	3.5	2
SLT020	20		2	35	56	39.7	29	2	4	2.5
SLT025	25		4	42	71	50.3	36	3	4	2.5
SLT030	30		4	47	80	60	42	3	4	2.5
SLT040	40		4	64	100	70	52	4	6	3.5
SLT050	50		4	80	125	91	58	4	8	4

B

Ball Spline

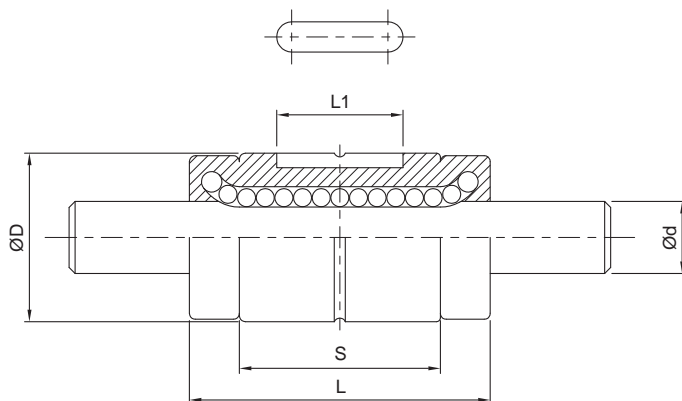

Model No.	Basic Load Rating		Basic Torsion		Static Permissible Moment		Mass	
	C	C ₀	C _T	C _{0T}	M _{A1}	M _{A2}	Spline Nut	Spline Shaft
	kgf	kgf	kgf · m	kgf · m	kgf · m	kgf · m	g	kg/m
SLT006	137	225	0.46	0.76	0.39	3.48	14	0.22
SLT008	137	225	0.60	0.99	0.39	3.82	16	0.39
SLT010	285	397	1.62	2.25	0.95	8.53	37	0.60
SLT013	396	540	2.89	3.94	1.50	12.46	52	1.03
SLT016	545	849	4.77	7.43	3.71	26.09	130	1.56
SLT020	724	1109	7.90	12.09	5.53	38.00	188	2.44
SLT025	1003	1593	21.99	43.01	10.35	68.59	285	3.80
SLT030	1160	1960	30.26	62.93	15.68	93.27	395	5.49
SLT040	2972	4033	105.37	176.05	36.59	264.34	843	9.69
SLT050	4086	5615	179.89	304.35	51.58	428.72	1758	15.19

TBI MOTION BALL SPLINE

3-2 Nominal Model Code of Ball Spline SO Series

■ 3-2-1 Nominal Model Code

TBI MOTION ball Splines is classified into interchangeable and non- interchangeable types. Their dimensions are the same; the only difference between the two types is that for non-interchangeable series, **TBI MOTION** will finish every process in the production line and meet customers' demands. Interchangeable nuts and shafts can be freely exchanged and the standard of the preload is P0. Customers could adjust the preload by changing the steel balls inside of the nut by themselves. It is very convenient for customers to have **TBI MOTION** ball splines in inventory and make the preload and end machining by themselves. **TBI MOTION** is proud of internal quality control process which is under strict international regulation.

Non-interchangeable Type Code :

SOF 008 T2 D N S - 500 - P0 - B2 + N3 N3

①
②
③
④
⑤
⑥
⑦
⑧
⑨
⑩
⑪

①	②	③	④
Spline Nut	Nominal Diameter	Groove	Flange Type
SOF : Flanged SOT : Cylindrical	Unit : mm	T2 : 2 Rows	D : Flange cutting (No Symbol When It is Without the Flange)

⑤	⑥	⑦
Accuracy Grade of Spline Shaft	Spline Shaft Type	Overall Length of Spline Shaft
N : Normal H : High P : Precision	S : Solid H : Hollow	Unit : mm

⑧	⑨	⑩
Preload Value	Number of Spline Nut	Nut Surface Treatment
P0 : No preload P1 : Light preload	(Leave blank if only one nut is required) Ex : Two install spline nuts on a shaft : B2	S : Standard B1 : Black Oxidation N1 : Hard Chrome Plating P : Phosphating N3 : Nickel Plating N4 : Raydent N5 : Chrome Plating

⑪
Shaft Surface Treatment
S : Standard
B1 : Black Oxidation
N1 : Hard Chrome Plating
P : Phosphating
N3 : Nickel Plating
N4 : Raydent
N5 : Chrome Plating

※No symbol required when plating is not needed.

Nominal Model Code for Interchangeable SO Type

Interchangeable Type of Spline Nut :

SOF 013 T2 D + N3

① ② ③ ④ ⑤

① Spline Nut	② Nominal Diameter	③ Groove	④ Flange Type
SOF : Flanged SOT : Cylindrical	Unit : mm	T2 : 2 Rows	N : Round (No Symbol When It is Without the Flange)

⑤

Nut Surface Treatment
S : Standard
B1 : Black Oxidation
N1 : Hard Chrome Plating
P : Phosphating
N3 : Nickel Plating
N4 : Raydent
N5 : Chrome Plating

Interchangeable Type of Spline Shaft :

SK 008 T2 N S - 500 + N3

① ② ③ ④ ⑤ ⑥ ⑦

① Nominal Model Code	② Nominal Diameter	③ Groove	④ Accuracy Grade of Spline Shaft
	Unit : mm	T2 : 2 Rows	N : Normal

⑤ Spline Shaft Type	⑥ Overall Length of Spline Shaft	⑦ Nut Surface Treatment
S : Solid H : Hollow	Unit : mm	S : Standard B1 : Black Oxidation N1 : Hard Chrome Plating P : Phosphating N3 : Nickel Plating N4 : Raydent N5 : Chrome Plating

TBI MOTION BALL SPLINE

3-2 Nominal Model Code of Ball Spline SO Series

SOF, SOT Spline Shaft Cross-Sectional Shape

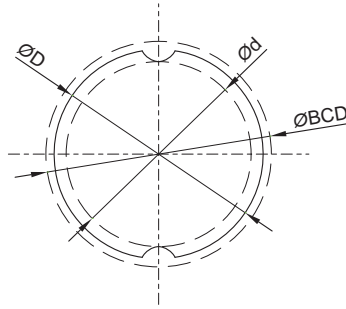

Solid Spline Shaft

Table 3.2.1 Solid Spline Shaft Cross-Sectional Shape

Unit : mm

Nominal Diameter	8	10	12	15	20	25
Stats						
Inner Diameter Ød	7	8.9	10.9	11.6	15.7	19.4
Outer Diameter ØD h7	8	10	12	13.6	18.2	22.6
Mass(kg/m)	0.39	0.605	0.875	1.11	2.02	3.1
Ball Center ØBCD	9.3	11.6	13.6	15	20	25
Tolerance µm	0 -15	0 -18	0 -18	0 -18	0 -21	0 -21

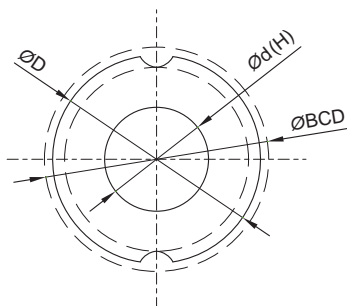

Hollow Spline Shaft

Table 3.2.2 Hollow Spline Shaft Cross-Sectional Shape

Unit : mm

Nominal Diameter	8	10	12
Stats			
Inner Diameter $\varnothing d$	3	4	6
Outer Diameter $\varnothing D$ h7	8	10	12
Mass(kg/m)	0.33	0.51	0.66
Ball Center $\varnothing BCD$	9.3	11.6	13.6
Tolerance μm	0 -15	0 -18	0 -18

TBI MOTION BALL SPLINE

3-2 Nominal Model Code of Ball Spline SO Series

SOF Series Specifications

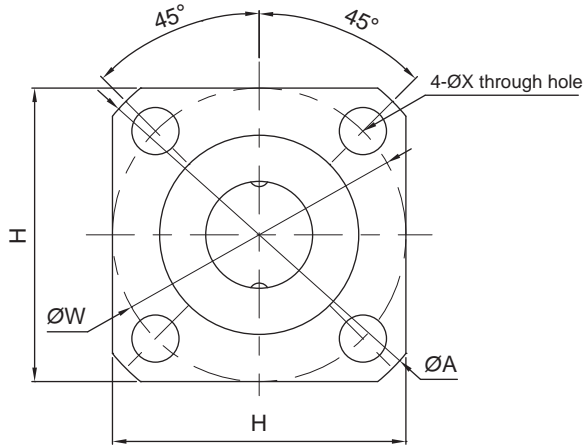

Model No.	Diameter		Row	Spline Nut Dimension							Mounting Hole
	d	h7		D	L	A	B	E	F	W	X
	SOF008	8		2	15	25	28	3.8	5.2	22	22
SOF010	10	2	19	30	36	4.1	5.9	28	28	4.5	
SOF012	12	2	21	35	38	4	6	30	30	4.5	
SOF015	13.6	2	23	40	40	4.5	6.5	31	32	4.5	
SOF020	18.2	2	30	50	46	5.5	8.5	35	38	4.5	
SOF025	22.6	2	37	60	57	6.6	10.4	43	47	5.5	

B

Ball Spline

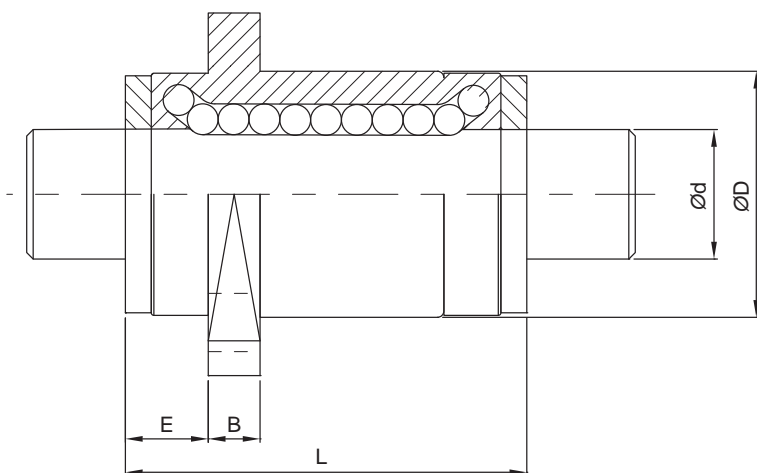

Model No.	Basic Load Rating		Basic Torsion		Static Permissible Moment		Mass	
	C	C ₀	C _T	C _{0T}	M _{A1}	M _{A2}	Spline Nut	Spline Shaft
	kgf	kgf	kgf · m	kgf · m	kgf · m	kgf · m	g	kg/m
SOF008	121	136	0.56	0.63	0.34	2.24	23.5	0.39
SOF010	192	219	1.11	1.27	0.71	4.23	45	0.61
SOF012	222	274	1.51	1.87	1.08	6.02	59	0.88
SOF015	426	619	3.19	4.65	2.83	15.49	77	1.11
SOF020	673	922	6.73	9.22	4.95	29.36	150	2.02
SOF025	1142	1458	14.17	18.14	9.46	56.17	255	3.10

TBI MOTION BALL SPLINE

3-2 Nominal Model Code of Ball Spline SO Series

SOT Series Specifications

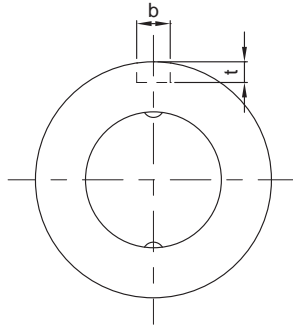

< Two row >

Shaft diameter

Model No.	Diameter	Row	Spline Nut Dimension				Keyway Dimensions	
	d		D	L	S	L1	b	t
	h7						H8	+0.05 ~ 0
SOT008	8	2	15	25	14.6	8.5	2.5	1.5
SOT010	10	2	19	30	18.2	11	3	1.8
SOT012	12	2	21	35	23	15	3	1.8
SOT015	13.6	2	23	40	27	20	3.5	2
SOT020	18.2	2	30	50	33	26	4	2.5
SOT025	22.6	2	37	60	39.2	29	5	3

B

Ball Spline

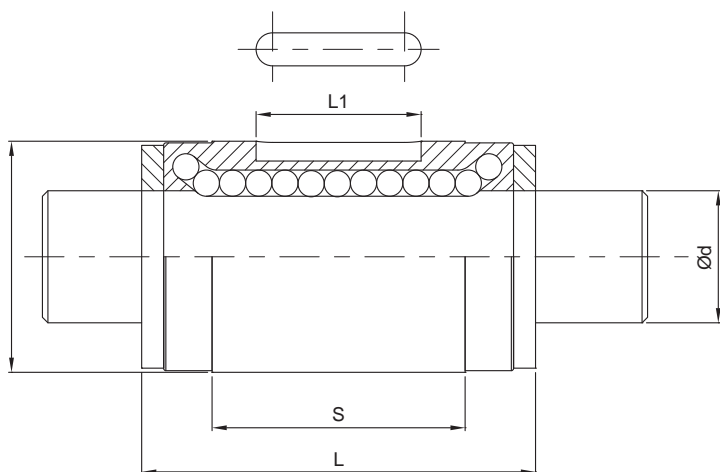

Model No.	Basic Load Rating		Basic Torsion		Static Permissible Moment		Mass	
	C	C ₀	C _T	C _{0T}	M _{A1}	M _{A2}	Spline Nut	Spline Shaft
	kgf	kgf	kgf · m	kgf · m	kgf · m	kgf · m	g	kg/m
SOT008	121	136	0.56	0.63	0.34	2.24	15.9	0.39
SOT010	192	219	1.11	1.27	0.71	4.23	31.5	0.61
SOT012	222	274	1.51	1.87	1.08	6.02	44	0.88
SOT015	426	619	3.19	4.65	2.83	15.49	59.5	1.11
SOT020	673	922	6.73	9.22	4.95	29.36	130	2.02
SOT025	1142	1458	14.17	18.14	9.46	56.17	220	3.10

Memo

A large area of horizontal dashed lines for writing.

Ball Screw

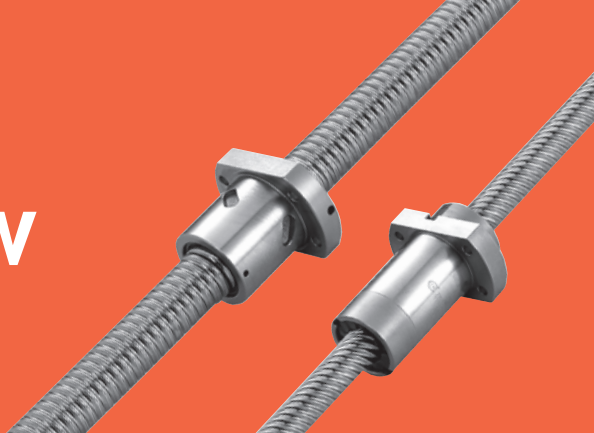

1-1 Features of TBI MOTION Ball Screw	C02
1-2 Ball Screw Selection Procedure.....	C04
1-3 Accuracy	C05
1-4 Screw Shaft Design	C11
1-5 Driving Torque	C17
1-6 Nut Design.....	C19
1-7 Rigidity.....	C21
1-8 Positioning Accuracy	C24
1-9 Service Life Design.....	C26
1-10 Cautions About Use of Ball Screws.....	C32
2-1 Nominal Model Code of Ball Screw.....	C36
2-2 Precision Ground Ball Screw Series.....	C39
2-2-1 TBI MOTION Nut of Precision Ground Ball Screw Type	C39
2-3 Rolled Ball Screw	C62
2-3-1 Rolled Screws.....	C62
2-3-2 The Features of TBI MOTION Rolled Ball Screw.....	C62
2-3-3 Nominal Model Code of Rolled Ball Screws	C62
2-3-4 Preload of Rolled Ball Screw	C65
2-4 Rolled Ball Screw Series.....	C66
2-4-1 TBI MOTION Nut of Rolled Ball Screw Type.....	C66

ABOUT BALL SCREW

1-1 Features of *TBI MOTION* Ball Screw

(1) High Reliability

TBI MOTION applies stringent quality control standards on every production process. With proper lubrication and use, trouble-free operation for an extended period of time is possible.

(2) Smooth Operation

The high efficiency of ball screw is vastly superior than conventional screws as shown in Fig 1.1.1. It takes less than 30% torque to make the linear motion into rotary motion.

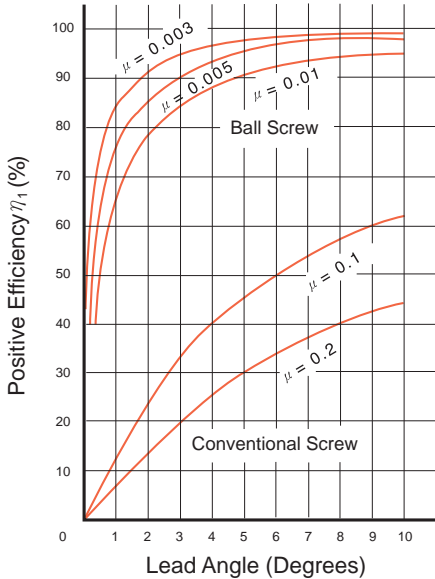

Normal usage (to convert rotary motion to linear motion)

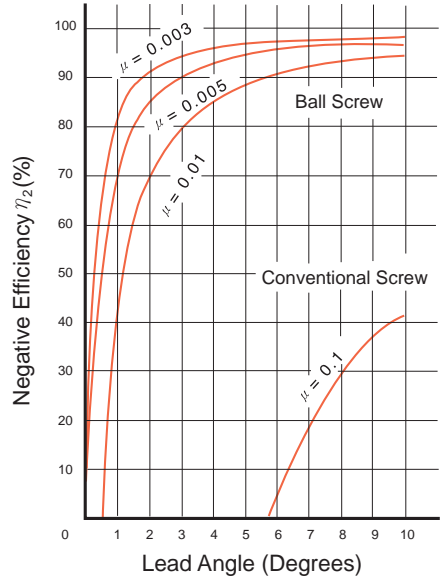

Special usage (to convert linear motion to rotary motion)

μ : friction coefficient

$$P = \frac{2\pi\eta_1 \times T}{\ell}$$

T = Torque kgf · cm
 P = Force kgf
 = Lead cm
 η_1 = Efficiency

$$T = \frac{\ell \times \eta_2 \times P}{2\pi}$$

T = Torque kgf · cm
 P = Force kgf
 = Lead cm
 η_2 = Efficiency

Fig 1.1.1 Mechanical Efficiency of Ball Screws

(3) High Rigidity and Preload

As figure 1.1.2 shown in below, the ball screw of TBI MOTION is designed with Gothic arch groove, which makes the screw easy to rotate even using minimum axial play. To make the rigidity more appropriate to using condition, you can change the preload between one or two screw nuts to reduce axial play.



Fig 1.1.2 Groove Shape of *TBI MOTION* Precision Ball Screw

(4) Circulation Method

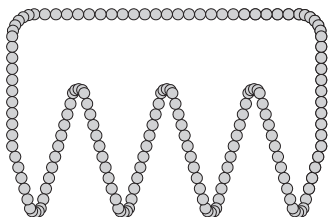

Fig 1.1.3 External Ball Circulation Nuts

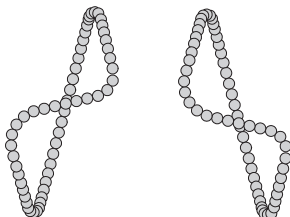

Fig 1.1.4 Internal Ball Circulation Nuts

(5) High Durability

As figure 1.1.2 shown in below, the ball screw of TBI MOTION is designed with Gothic arch groove, which makes the screw easy to rotate even using minimum axial play. To make the rigidity more appropriate to using condition, you can change the preload between one or two screw nuts to reduce axial play.

Table 1.1.1 Material and Heat Treatment

Item	Material	Hardness
Screw	SCM450 S55C	HRC 58°~62°
Nut	SCM420	HRC 58°~62°
Steel Ball	SUJ2	HRC 60°UP

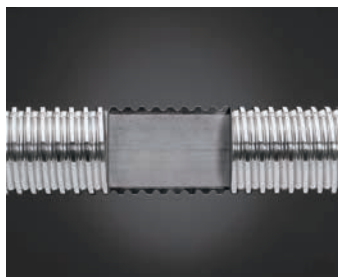
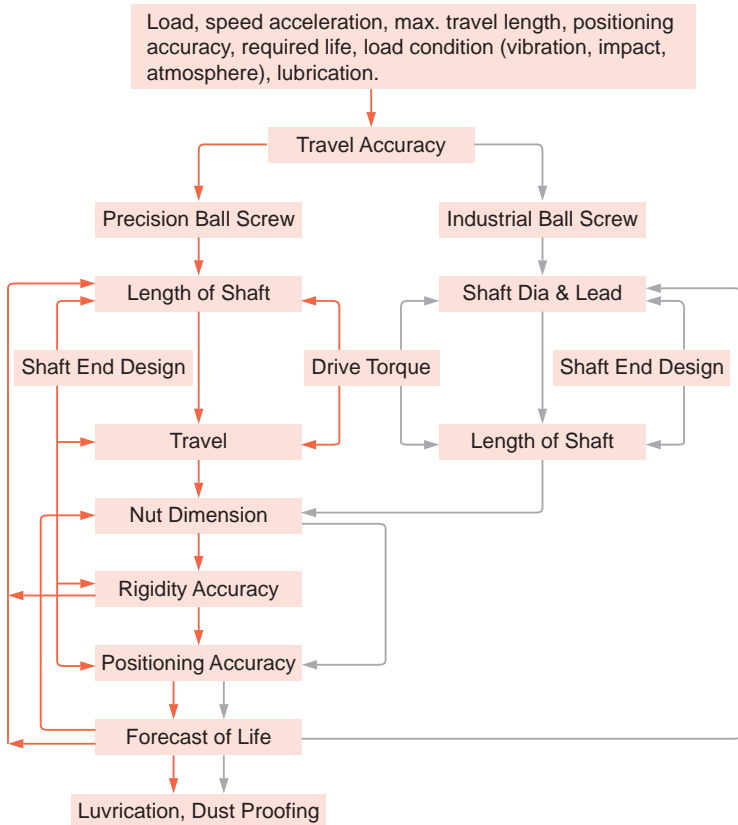

Fig 1.1.5 Heat Treatment

ABOUT BALL SCREW

1-2 Ball Screw Selection Procedure



Accuracy (C05)
Screw Shaft Design (C11)
Drive Torque (C17)
Nut Design (C19)

Rigidity (C21)
Positioning Accuracy (C24)
Life Design (C26)
Lubrication and safety design (C32)

1-3 Accuracy

1-3-1 Lead/Travel Accuracy

According to the standard of JIS, we classified our lead accuracy through E, e, e₃₀₀ and e_{2π}, four main regulations. As figure 1.3.1 ~ 1.3.3 shown in below, all the definition and tolerance are specified. To test the accumulated travel deviations for grade C7 and C10, the tolerance will be chosen in random 300mm of useful length and evaluated if it is qualified with the e₃₀₀ table of 1.3.3.

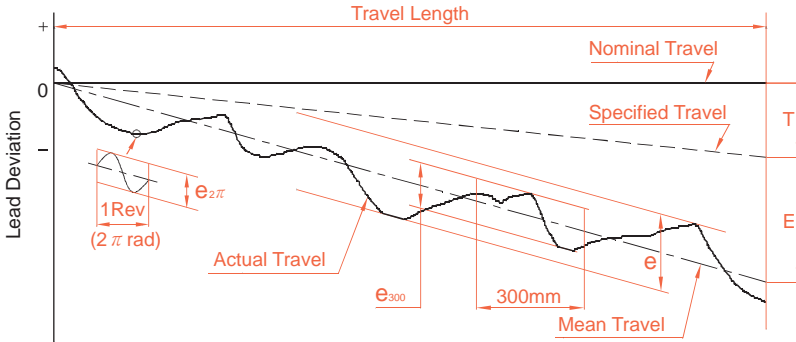

Fig 1.3.1 Diagram of Lead Accuracy

Terms	Reference	Definition	Allowable
Travel Compensation	T	Travel compensation is the deduction between specified and nominal travel in the useful travel. A slightly smaller value compared with nominal travel is often selected by customer, to compensate for an expected elongation caused by temperature rise or external load. Therefore " T " is usually a negative value. <i>Note : if no compensation is needed, specified travel is the same as nominal travel.</i>	
Actual Travel		Actual travel is the axial displacement of the nut relative to the screw shaft.	
Mean Travel		Mean travel is the linear best fit line of actual. This could be obtained by the least squares method. This line represents the tendency of actual travel.	
Mean Travel Deviation	E	Mean travel deviation is the deduction between mean travel and specified travel within travel length.	Table 1.3.2
Travel Variations	e	Travel variations is the coverage of 2 lines drawn parallel to the mean travel.	Table 1.3.2
	e ₃₀₀	Maximum width of variation within the travel length.	Table 1.3.3
	e _{2π}	Actual width of variation for the length of 300mm taken anywhere within the travel length. Wobble error, actual width of variation for one revolution (2π radian)	Table 1.3.3

ABOUT BALL SCREW

1-3 Accuracy

Table 1.3.2 Mean Travel Deviation ($\pm E$) and Travel Variation (e) (JIS B 1192)

Unit : μm

Grade		C0		C1		C2		C3		C5		C7	C10		
Travel Length (mm)	Over	Incl.	$\pm E$	e	$\pm E$	e	$\pm E$	e	$\pm E$	e	$\pm E$	e	e	e	
		100		3	3	3.5	5	5	7	8	8	18	18	$\pm 50/300\text{mm}$	$\pm 210/300\text{mm}$
	100	200	3.5	3	4.5	5	7	7	10	8	20	18			
	200	315	4	3.5	6	5	8	7	12	8	23	18			
	315	400	5	3.5	7	5	9	7	13	10	25	20			
	400	500	6	4	8	5	10	7	15	10	27	20			
	500	630	6	4	9	6	11	8	16	12	30	23			
	630	800	7	5	10	7	13	9	18	13	35	25			
	800	1000	8	6	11	8	15	10	21	15	40	27			
	1000	1250	9	6	13	9	18	11	24	16	46	30			
	1250	1600	11	7	15	10	21	13	29	18	54	35			
	1600	2000			18	11	25	15	35	21	65	40			
	2000	2500			22	13	30	18	41	24	77	46			
	2500	3150			26	15	36	21	50	29	93	54			
	3150	4000			30	18	44	25	60	35	115	65			
	4000	5000					52	30	72	41	140	77			
	5000	6300					65	36	90	50	170	93			
	6300	8000							110	60	210	115			
	8000	10000									260	140			
	10000	12500									320	170			

Table 1.3.3 Variation per 300mm (e_{300}) and Wobble Error ($e_{2\pi}$) (JIS B 1192)

Unit : μm

Grade	C0	C1	C2	C3	C5	C7	C10
e_{300}	3.5	5	7	8	18	50	210
$e_{2\pi}$	2.5	4	5	6	8		

1-3-2 Axial Play

Axial play of **TBI MOTION's** precision ball screw is shown in

Table 1.3.4 Classification of Axial Play

Grade	P0	P1	P2	P3	P4
Axial Play	Yes	No	No	No	No
Preload	No	No	Light	Medium	Heavy

Excessive preload increases the friction torque and generates heat which will reduce the life expectancy. However, insufficient preload will reduce stiffness and increase the possibility of lost motion. **TBI MOTION** recommends that the preload applied on CNC machine tools should not heavier than 8% of the dynamic load; 5% for industrial automation X-Y table.

Table 1.3.5 The reference spring force of (P2)

Model No.	Spring Force (Kg) Single Nut	Spring Force(Kg) Double Nut
1605	0.1~0.3	0.3~0.6
2005	0.1~0.3	0.3~0.6
2505	0.2~0.5	0.3~0.6
3205	0.2~0.5	0.5~0.8
4005	0.2~0.5	0.5~0.8
2510	0.2~0.5	0.5~0.8
3210	0.3~0.6	0.5~0.8
4010	0.3~0.6	0.5~0.8
5010	0.3~0.6	0.8~1.2
6310	0.6~1.0	0.8~1.2
8010	0.6~1.0	0.8~1.2

Table 1.3.6 Axial Play (P0) Clearance in the Axial Direction of Rolled and Ground Ball Screw Unit : mm

Nominal Diameter	Rolled Ball Screw Clearance in the Axial Direction (max.)	Ground Ball Screw Clearance in the Axial Direction (max.)
Ø04~Ø14 miniature ball screw	0.05	0.015
Ø15~Ø40 middle size of ball screw	0.08	0.025
Ø50~Ø100 big size of ball screw	0.12	0.05

ABOUT BALL SCREW

1-3 Accuracy

■ 1-3-3 Definition of Mounting Accuracy and Tolerance on Ball Screw

The main items of the mounting accuracy of ball screw are listed in below.

- (1) Periphery run-out of the supporting part of the screw shaft to the screw groove.
- (2) Concentricity of a mounting portion of the shaft to the adjacent ground portion of the screw shaft.
- (3) Perpendicularity of the shoulders to the adjacent ground portion of the screw shaft.
- (4) Perpendicularity of the nut flange to the axis of the screw shaft.
- (5) Concentricity of the ball nut diameter to the screw groove.
- (6) Parallelism of the mounting surface of a ball nut to the screw groove.
- (7) Total run-out of the screw shaft to the axis of the screw shaft.

All **TBI MOTION** ball screws are manufactured, inspected and guaranteed to be within specifications.

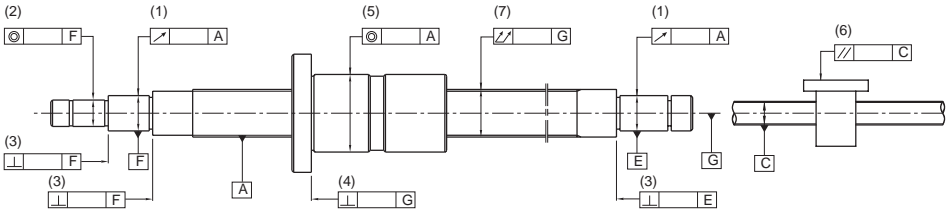

Fig 1.3.2 Mounting Accuracy and Tolerance

■ 1-3-4 Preload Torque

As figure 1.3.3 shown in below, it specified all the type of preload torque generated by rotating a preloaded ball screw.

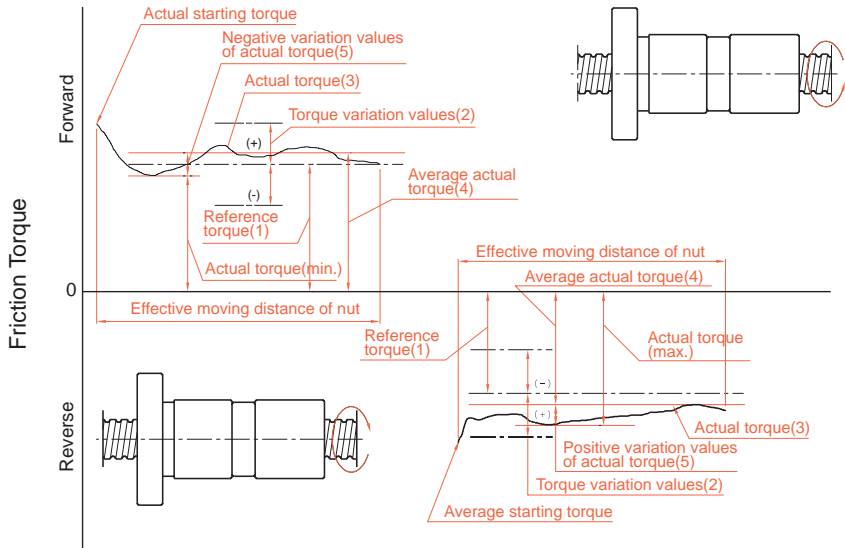

Fig 1.3.3 Descriptions of preload torque

Glossary

(1) Preload

To generate the inner force inside the ball screw to decrease the clearance and increase the rigidity, a set of one gage (approximately 2μ) larger steel balls is filled inside the nut or two nuts which are executing mutual displacement in axial direction.

(2) Preload dynamic torque

The dynamic torque required for continuously rotating the screws shaft or the nuts under unload condition and the preload has applied to the ball screws.

(3) Reference torque

The targeted preload dynamic torque Fig 1.3.3-(1)

(4) Torque variation values

The variation values of the targeted preload torque variation rates are specified generally based on JIS standards as indicated in Fig 1.3.3.

(5) Torque variation rate

The variation ratio of reference torque.

(6) Actual torque

The actual measured preload dynamic torque of the ball screws.

(7) Average actual torque

The arithmetic average of the maximal and minimal actual torque values measured when the nuts are doing reciprocating movements.

(8) Actual torque variation values

After the nut doing reciprocating movements on the effective length of the thread, the biggest variation tested will be the actual torque variation value, which is covered between the positive and negative minimum value relative to the actual torque.

(9) Actual torque variation rate

The rate of actual torque variation values in relation of the average actual torque.

ABOUT BALL SCREW

1-3 Accuracy

Table 1.3.7 Permissible ranges of torque variation rates

Reference torque kgf·cm		Effective threading length mm										
		Below 4000								4000~10000		
		Slenderness 1 : below 40				Slenderness 1 : 40~1 : 60				-		
		Grade				Grade				Grade		
Over	Incl	C0	C1	C2, C3	C5	C0	C1	C2, C3	C5	C1	C2, C3	C5
2	4	±35%	±40%	±45%	±55%	±45%	±45%	±55%	±65%	-	-	-
4	6	±25%	±30%	±35%	±45%	±38%	±38%	±45%	±50%	-	-	-
6	10	±20%	±25%	±30%	±35%	±30%	±30%	±35%	±40%	-	±40%	±45%
10	25	±15%	±20%	±25%	±30%	±25%	±25%	±30%	±35%	-	±35%	±40%
25	63	±10%	±15%	±20%	±25%	±20%	±20%	±25%	±30%	-	±30%	±35%
63	100	-	-	±15%	±20%	-	-	±20%	±25%	-	±25%	±30%

Remarks : 1. Slenderness is the value of dividing the screws shaft outside diameter with the screws shaft threading length.
2. For reference torque less than 2 kgf·cm, **TBI MOTION** specifications will apply.

Calculation of Reference Torque T_p

The equation for computing reference torque of the ball screws is given in following :

$$T_p = 0.05 (\tan\beta)^{-0.5} \cdot \frac{F_{a0} \cdot \ell}{2\pi}$$

Where, F_{a0} = Preload (kgf)
 β = Lead angle
 ℓ = Lead (cm)

Measurement Conditions

The measure condition as indicated in Fig 1.3.4, the preload dynamic torque will be the multiplication of F (The force to make the nut stay still during rotating the screw) and L (The arm of force).

$$T_p = F \cdot L$$

Measure conditions

- (1) Measurement is executed under the condition of unattached with scraper.
- (2) The rotating speed during measurement maintains at 100 rpm.
- (3) According to JSK2001(industrial lubrication oil viscosity standard), the lubrication oil used should be in compliance with ISO VG68.

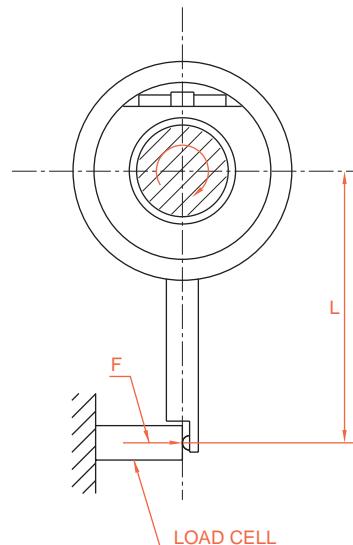

Fig 1.3.4 Preload dynamic torque measuring method

1-4 Screw Shaft Design

1-4-1 Mounting Methods

It's important to consider mounting method (Fig 1.4.1~1.4.8) during your selection of ball screw specification. If you have special requirement related with mounting method, please consult TBI MOTION.

(Mounting Screw and Nut)

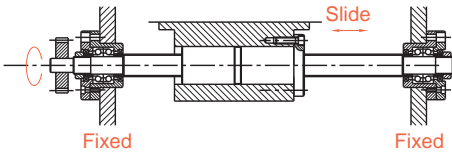

Fig 1.4.1

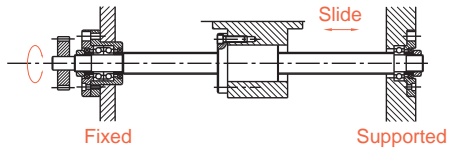

Fig 1.4.5

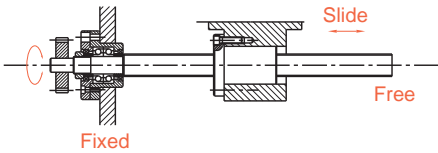

Fig 1.4.2

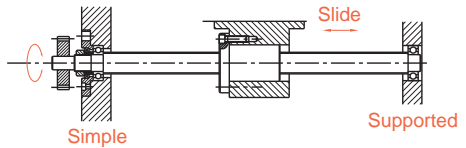

Fig 1.4.6

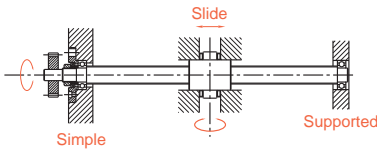

Fig 1.4.3

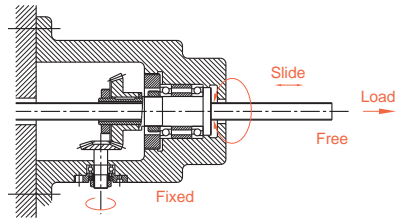

Fig 1.4.7

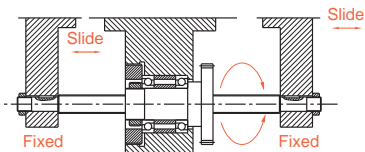

Fig 1.4.4

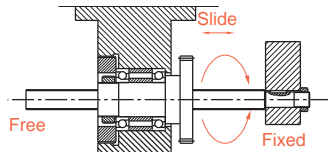

Fig 1.4.8

ABOUT BALL SCREW

1-4 Screw Shaft Design

(The mounting method for common types of machinery.)

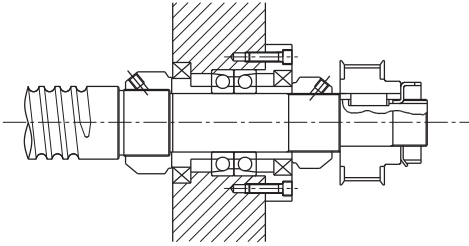

Fig 1.4.9

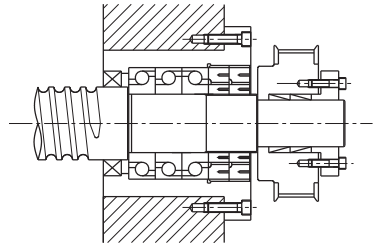

Fig 1.4.11

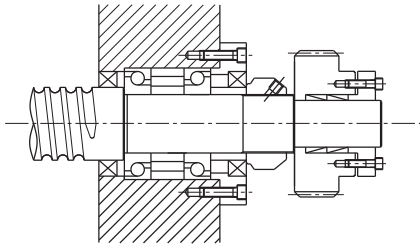

Fig 1.4.10

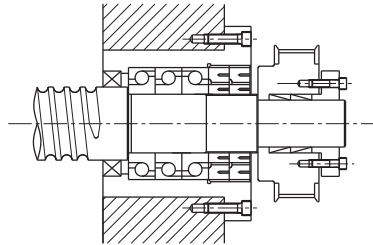

Fig 1.4.12

(The mounting method for bearing in a given pretension.)

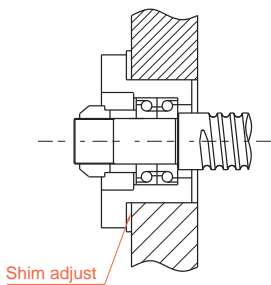

Fig 1.4.13

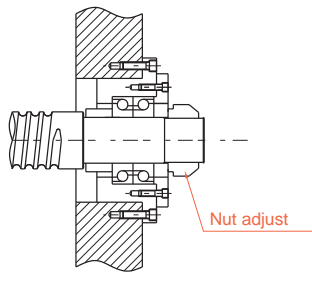

Fig 1.4.14

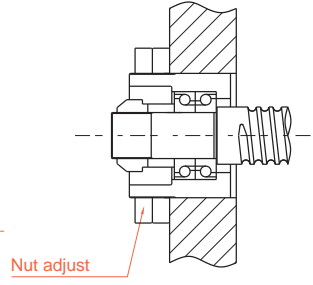

Fig 1.4.15

■ 1-4-2 Allowable Load of Axial Direction

(1) Buckling Load

The safety of the screw shaft against buckling needs to be checked when the shaft is expected to receive buckling loads. Fig 1.4.16 shows a diagram which summarizes the allowable compressive load for buckling for each nominal outside diameter of screw shaft. (Calculate with the equation shown in below when the nominal outside diameter of the screw shaft exceeds 125mm.)

Select the graduation of allowable axial load according to the method of ball screw support method.

$$P = \alpha \cdot \frac{I \cdot N \cdot \pi^2 \cdot E}{L^2} = m \frac{dr^4}{L^2} \cdot 10^3$$

Where

α = Safety Factor ($\alpha = 0.5$)

E : Vertical elastic modules ($E = 2.1 \cdot 10^4 \text{ kgf/mm}^2$)

I : Min. secondary moment of screw shaft sectional area

$$I = \frac{\pi}{64} dr^4 (\text{mm}^4)$$

dr : Screw shaft root diameter (mm)

L : Mounting distance (mm)

m · N : Coefficient determined from mounting method of ball screw

Floated-Floated m = 5.1 (N = 1)

Fixed-Floated m = 10.2 (N = 2)

Fixed-Fixed m = 20.3 (N = 4)

Fixed-Free m = 1.3 (N = 1/4)

(2) Allowable Tensile/Buckling Load

With shorter mounting distance, please calculate the two items describe in below.

1. The allowable tensile / buckling load which equals to the derating stress.

2. Allowable load of the screw's groove.

$$P = \sigma A = 11.8 dr^2 (\text{kgf})$$

Where,

P : Buckling load (kgf)

σ : Allowable tensile compressive stress (kgf/mm^2)

A : Sectional area of screw shaft root bottom diameter (mm^2)

dr : Screw shaft root diameter (mm)

ABOUT BALL SCREW

1-4 Screw Shaft Design

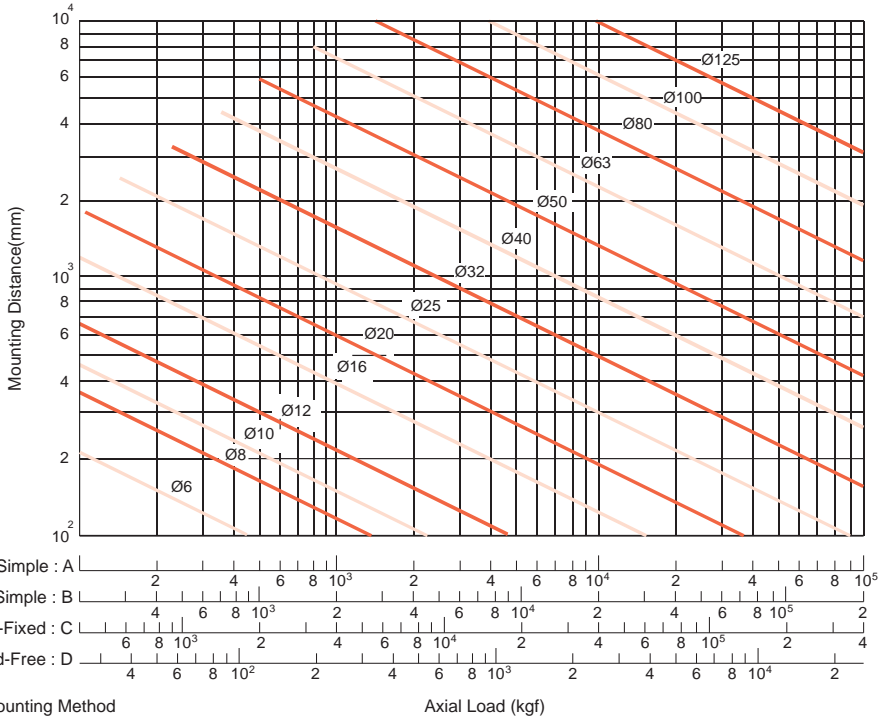

Fig 1.4.16 Buckling Load vs. Nominal Diameter and Length

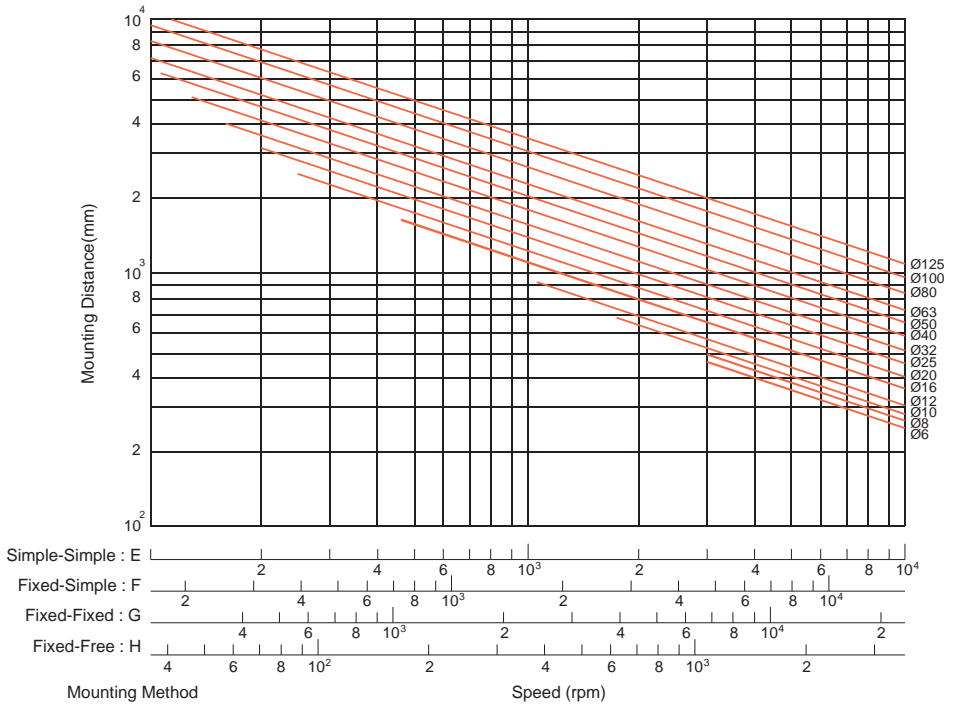

Fig 1.4.17 Buckling Load vs. Nominal Diameter and Length

ABOUT BALL SCREW

1-4 Screw Shaft Design

■ 1-4-3 Critical Speed

(1) Dangerous speed

To prevent the screw's natural frequency attain resonance which will occur critical speed, it's necessary to look into the ball screw allowable rotation speed (Below 80% of the Critical Speed). More detail of allowable rotation speed classified though screw diameter please refer to Fig 1.4.17.

(2) $dm \cdot n$ value

The allowable rotation speed is regulated also by the $Dm \times N$ value (Dm : diameter of central circle of steel ball, N : Revolution speed, rpm) which expresses the peripheral speed.

Generally,

For precision

(accuracy grade C7 to C0)
 $Dm \times N \leq 70,000$

For general industry (C10)
 $Dm \times N \leq 50,000$

If your requirement about the product will exceed the limitation, please contact with TBIMOTION to discuss the detailed solution for the ideal product.

※ When ϵ , the ratio of screw length and shaft diameter has exceeded 70, please contact with TBIMOTION to arrange the special arrangement for production.

$$n = \alpha \cdot \frac{60\lambda^2}{2\pi L^2} \sqrt{\frac{Eg}{\gamma A}} = f \frac{dr}{L^2} \cdot 10^7 (\text{rpm})$$

Where

α : Safty factor ($\alpha = 0.8$)

E : Verticle elastic modules ($E = 2.1 \cdot 10^4 \text{kgf/mm}^2$)

I : Minimum secondary torque of axial section plane

$$I = \frac{\pi}{64} dr^4 (\text{mm}^4)$$

dr : Screw shaft root diameter (mm)

g : Acceleration of gravity ($g = 9.8 \cdot 10^3 \text{mm/s}^2$)

γ : Density ($\gamma = 7.8 \cdot 10^{-3} \text{kgf/mm}^3$)

A : Screw shaft sectional area ($A = \pi dr^2/4 \text{mm}^2$)

L : Mounting distance (mm)

f, λ : Coefficient determined from the ball screw mounting method

Floated-Floated $f = 9.7$ ($\lambda = \pi$)

Fixed-Floated $f = 15.1$ ($\lambda = 3.927$)

Fixed-Fixed $f = 21.9$ ($\lambda = 4.730$)

Fixed-Free $f = 3.4$ ($\lambda = 1.875$)

1-5 Driving Torque

1-5-1 Driving torque T_s of the transmission shaft

$T_s = T_P + T_D + T_F$ (in fixed speed)

$T_s = T_G + T_P + T_D + T_F$ (when accelerating)

T_G : Acceleration torque (1) T_P : Load torque (2)

T_D : Preload torque (3) T_F : Friction torque (4)

(1) Acceleration T_G

$$T_G = J\alpha \text{ (kgf} \cdot \text{cm)}$$

$$\alpha = \frac{2\pi n}{60\Delta t} \text{ (rad/s}^2\text{)}$$

J : Moment of inertia (kgf · cm · s²)

α : Angular acceleration (rad/s²)

n : Revolutions (min⁻¹)

Δt : Starting time (sec)

(3) Preload torque T_D

$$T_D = \frac{K \cdot P_{PL} \cdot \ell}{\sqrt{\tan \alpha} \cdot 2\pi} \text{ (kgf} \cdot \text{cm)}$$

K : Internal coefficient

(0.05 is usually adopted)

P_{PL} : Preload (kgf)

ℓ : Lead (cm)

α : Lead angle

(4) Friction torque T_F

$$T_F = T_B + T_O + T_I \text{ (kgf} \cdot \text{cm)}$$

T_B : Friction torque of bracing shaft

T_O : Friction torque of free shaft

T_I : Friction torque motor shaft

(2) Lead torque T_P

$$T_P = \frac{P \cdot \ell}{2\pi\eta_1} \text{ (kgf} \cdot \text{cm)}$$

$P = F + \mu Mg$

P : Axial load (kgf)

ℓ : Load (cm)

η_1 : Positive efficiency

The efficiency when rotating motion is altered to linear motion

F : Cutting force (kgf)

μ : Friction

M : Mass of moving object (kg)

g : Acceleration of gravity (9.8 m/s²)

$$T_P = \frac{P \cdot \ell \cdot \eta_2}{2\pi} \text{ (kgf} \cdot \text{cm)}$$

η_2 : Reverse efficiency

The efficiency when linear motion returns to rotating motion

The friction torque of the bracing shaft would be affected by the volume of lubrication oil. Besides, be careful with the excessive tight end seal may lead to unexpected over friction torque or temperature rise.

【For reference】 Moment of inertia of load (refer to Table 1.5.1)

$$J = J_{BS} + J_{CU} + J_W + J_M$$

J_{BS} : Moment of inertia Ball screws shaft

J_{CU} : Moment of inertia Coupler

J_W : Moment of inertia Linear motion part

J_M : Moment of inertia Roller shaft part of motor shaft

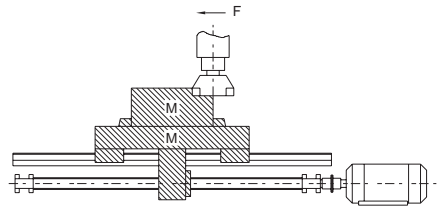

Fig 1.5.1 Moment of inertia of load

ABOUT BALL SCREW

1-5 Driving Torque

Table1.5.1 Conversion formula for moment of inertia of load

Formula	J
Moment of inertia converted from motor shaft	
Cylinder load	$\frac{\pi\rho LD^4}{32}$
Linearly moving object	$\frac{M}{4} \left(\frac{V\ell}{\pi \cdot N_M} \right)^2 = \frac{M}{4} \left(\frac{P}{\pi} \right)^2$
Unit	kg · m ²
Moment of inertia during deceleration	$J_M = \left(\frac{J_\ell}{N_M} \right)^2 J \ell$

ρ : Density (kg/m³) $\rho = 7.8 \cdot 10^3$

L : Cylinder length (m)

D : Cylinder diameter(m)

M : Mass of the linear motion part (kg)

V : Velocity of the linear moving object (m/min)

N_M : Motor shaft revolutions (min⁻¹)

P : The moving magnitude of the linearly moving object per rotation of the motor (m)

N ℓ : Rotations in longitudinal moving direction (min⁻¹)

J ℓ : Moment of inertia in load direction

J_M : Moment of inertia in motor direction

■ 1-6-1 Selection of Nut

(1) Series

When making selection of series, please take demanded accuracy, intended delivery time, dimensions(the outside diameter of screw, ratio of lead/ the outside diameter of screw) preload and etc into consideration.

(2) Circulation type

Selection of circulation type : Please consider the efficiency of screw nut's mounting space. The advantage of each circulation type will be specified in figure 1.6.1.

(3) Number of loop circuits

Performance and service life should be considered when selecting number of loop circuits.

(4) Shape of flanges (FLANGE)

Please make selection based on the available space for the installation of nuts.

(5) Oil hole

Oil holes are provided for the precision ball screws, please use them during machine assembling and regular furnishing.

1-6 Nut Design

Table 1.6.1 Circulation type

Circulation type	Model		Characteristic
	Single Nut	Double Nuts	
Internal circulation type	SFM SFNI SFK SFNU BSH	DFM	<ul style="list-style-type: none"> • Delicated diameter of screw takes only little space. • Applicable to those with smaller lead / the outside diameter of the screw
External circulation type	SFV XSV BSH	DFV	<ul style="list-style-type: none"> • Economy • Applicable to larger lead and diameter. • Applicable for high loading purpose. (TBIMOTION patent nut)
End-caps circulation type	SFY SFH	DFS	<ul style="list-style-type: none"> • Suitable for high speed positioning

1-6-2 Nut Types

U, I, M - Type Nut

In these types of nuts, by using the internal circulator which makes the ball pass over the crest diagonally, the ball will return to the starting point. Normally, one roll of balls will fit with one circulation. As figure 1.6.1 specified, these types of nuts need at least one side which is completely tooth passing, which is applicable for smaller shaft diameter.

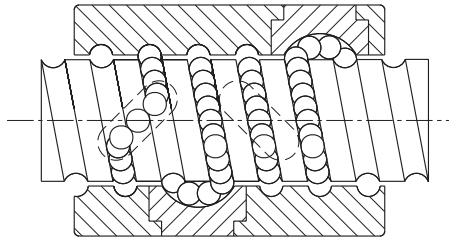

Fig 1.6.1 U, I, M - Type Nut

K - Type Nut

It applies the similar circulation as that of I-type, but circulation takes place in key slots of identical angle for different circulation. (see Fig 1.6.2)

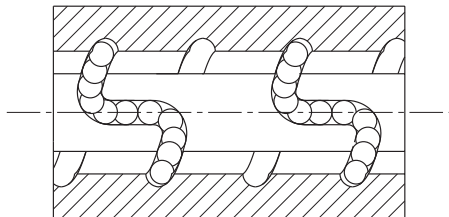

Fig 1.6.2 K - Type Nut

ABOUT BALL SCREW

1-6 Nut Design

V - Type Nut

Using outer circulation, the special design of circulator allows the balls to roll along the thread direction. By so, the smoothness of circulation is increased and meanwhile decrease the mutual collision. It's a suitable type for high speed and heavy loading.

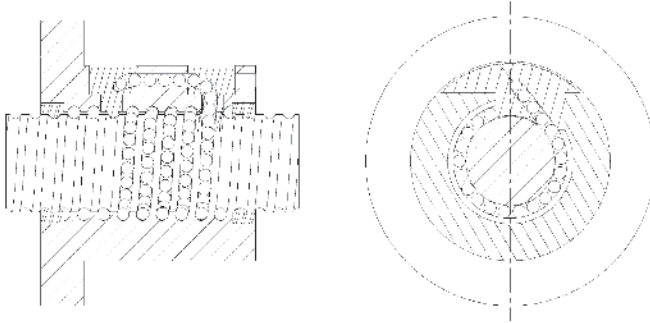

Fig 1.6.3 V - Type Nut

Y, H - Type Nut

By using thin and flexible dust cap on both side, the performance of wiping had been enhanced. Moreover, the enhancement of circulation structure increase both the function of high rigidity and speed.

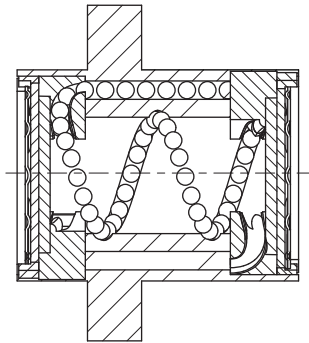

Fig 1.6.4 Y, H - type nut

1-7 Rigidity

Excessively weak rigidity of the screw's peripheral structure is one of the primary causes that result in lost motion. Therefore, in order to achieve excellent position accuracy for the precision machines such as NC working machines and etc, axial rigidity balance as well as torsional rigidity for the parts at various portions of the transmission screw have to be taken into consideration at time of designing.

Static Rigidity K

The axial elastic deformation and rigidity of the transmission screw system can be determined by the formula below.

$$K = \frac{P}{e} \text{ (kgf/mm)}$$

P : Axial load (kgf) borne by the transmission screw system

e : Axial flexural displacement (mm)

$$\frac{1}{K} = \frac{1}{K_S} + \frac{1}{K_N} + \frac{1}{K_B} + \frac{1}{K_H} \text{ (mm/kgf)}$$

K_S : Axial rigidity of screw shaft (1) K_B : Axial rigidity of support shaft (3)

K_N : Axial rigidity of nut (2) K_H : Axial rigidity of installation (4)

(1) Axial rigidity K_S and displacement δ_S

$$K_S = \frac{P}{\delta_S} \text{ (kgf/mm)}$$

P : Axial load (kgf)

For places of Fixed - Fixed installation For places other than Fixed - Fixed installation

$$\delta_{SF} = \frac{PL}{4AE} \text{ (mm)}$$

$$\delta_{SS} = \frac{PL_0}{AE} \text{ (mm)}$$

$$\delta_{SS} = 4\delta_{SF}$$

δ_{SF} : Directional displacement at places of fixed-fixed

δ_{SS} : Directional displacement at places excluding fixed-fixed installation

A : Cross-sectional area of the screw shaft tooth root diameter (mm²)

E : Longitudinal elastic modulus (2.1 · 10⁴kgf/mm²)

L : Distance between installations (mm)

L₀ : Distance between load applying points (mm)

ABOUT BALL SCREW

1-7 Rigidity

(2) Axial rigidity K_N and displacement δ_N of nuts

$$K_N = \frac{P}{\delta_s} \text{ (kgf/mm)}$$

(a) In case of single nut

$$\delta_{NS} = \frac{K}{\sin\beta} \left[\frac{Q^2}{d} \right]^{\frac{1}{3}} \cdot \frac{1}{\zeta} \text{ (mm)}$$

$$Q = \frac{P}{n \cdot \sin\beta} \text{ (kgf)}$$

$$n = \frac{D_0 \pi m}{d} \text{ (each)}$$

Q : Load of one steel ball (kgf)

n : Amount of steel ball

k : Constant determined based on material, shape, dimensions

$$k \approx 5.7 \cdot 10^{-4}$$

β : Angle of contact (45°)

P : Axial load (kgf)

d : Steel ball diameter (mm)

ζ : Accuracy, internal structure coefficient

m : Effective amount of balls

D_0 : Steel ball center diameter (mm)

$$D_0 = \frac{\ell}{\tan\alpha \cdot \pi} \text{ (kgf/mm)}$$

ℓ : Lead (mm)

α : Lead angle

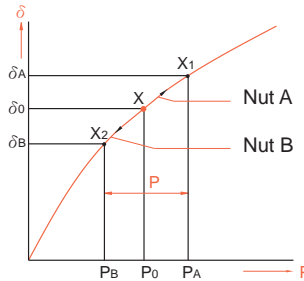

Fig 1.7.1

(b) In case of double nuts

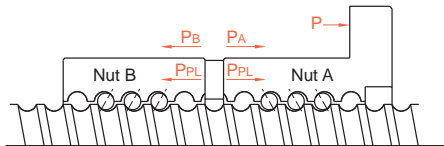

Fig 1.7.2 Preloaded for the double nuts

As bearing weight of preload (P_{PL}) exert, there will be approximately three times of axial loading (P). To eliminate the preload of nut b, please set the bearing weight of preload (P_{PL}) under 1/3 of the maximum axial load weight. Take 0.25 C_a as maximum load weight of preload. When the displacement under the preload which equals to three times of the bearing load of the axial direction, the value will be 1/2 of single nut's displacement.

$$K_N = \frac{P}{\delta_{NW}} = \frac{3P_{PL}}{\delta_{NS/2}} = \frac{6P_{PL}}{\delta_{NS}} \text{ (kgf/mm)}$$

δ_{NS} : Displacement of single nut (mm)

δ_{NW} : Displacement of double nuts (mm)

(Explanation of the rigidity of double nuts)

As shown in Fig 1.7.1 and 1.7.2, when a preload P_{PL} is applied on the nut A and B both nuts A, B would produce flexural deformations that will reach point X. If an external force P is exerted from here, nut A moves from point X to point X1, while nut B moves from X to X2.

Then, based on the computing formula for displacement δ_{NS} of the single nut, we can obtain :

$$\delta_0 = aP_{PL}^{\frac{2}{3}}$$

Since nut A and B have the displacement of $\delta_a = aP_{PL}^{\frac{2}{3}}$ while external force (P) gave the same displacement on nut A and B, we can obtain that $\delta_A - \delta_0 = \delta_0 - \delta_B$.

In other cases, if external force applied on nut A and B is P only, and cause the increase of P_A , we will get the formula of $P_A - P_B = P$ $\delta_B = 0$

$$P_A - P_B = P$$

$$\delta_B = 0$$

For preventing the external force applied on nut B being absorbed by nut A thus decreasing, so when $\delta_B = 0$

$$aP_A^{\frac{2}{3}} - aP_{PL}^{\frac{2}{3}} = aP_{PL}^{\frac{2}{3}}$$

$$P_A^{\frac{2}{3}} = 2P_{PL}^{\frac{2}{3}}$$

$$P_A = \sqrt[3]{8} P_{PL} \approx 3P_{PL}$$

As Fig 1.7.3 shown in below, if the axial direction loading weight equals to three times of preload, the single nut's displacement will be cut into half and gain two times stronger of rigidity.

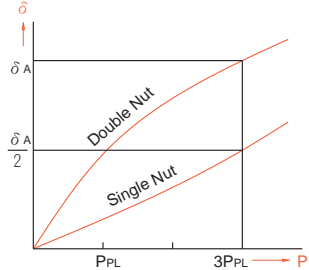

Fig 1.7.3

(3) Axial rigidity K_B and displacement δ_B of support shaft

$$K_B = \frac{P}{\delta_B} \text{ (kgf/mm)}$$

Q : Load of one steel ball (kgf)

n : Amount of steel balls

β : Angle of contact (45°)

P : Axial load (kgf)

d : Steel ball diameter (mm)

a : Effective stroke

Being the support bearing of ball screw and meanwhile applying on precision machines, we can calculate the rigidity of bevel ball bearing through the formula below.

$$\delta_B = \frac{2}{\sin\beta} \left[\frac{Q^2}{d} \right]^{\frac{1}{3}} \text{ (mm)} \quad Q = \frac{P}{n \cdot \sin\beta} \text{ (kgf)}$$

(4) Look into the nut and bearing mounting part's axial direction, the rigidity K_H and displacement δ_H should aware of the requirement of high rigidity on mounting portion during the initial machine development.

$$K_H = \frac{P}{\delta_H} \text{ (kgf/mm)}$$

ABOUT BALL SCREW

1-8 Positioning Accuracy

Among the factors that cause feed accuracy errors, lead accuracy and feed system rigidity are the key points for review, while other factors such as heat deformation due to temperature rise as well as assembly accuracy for the guiding surface, etc. should also be considered.

1-8-1 Accuracy Selection

Table 1.8.1 shows the recommended application ranges for various ball screws accuracy classes based on different.

Table 1.8.1 Examples of ball screws accuracy classes for different uses

Application			Accuracy Grade						
			C0	C1	C2	C3	C5	C7	C10
NC Machine Tools	Lathe	X	○	○	○	○	○	○	
		Y				○	○	○	
	Milling Machine Boring Machine	XY		○	○	○	○	○	
		Z			○	○	○	○	
	Machine Center	XY		○	○	○	○		
		Z			○	○	○		
	Jig Borer	Y	○	○					
		Z	○	○					
	Drilling Machine	XY				○	○	○	
		Z					○	○	
	Grinding Machine	X	○	○	○	○	○	○	
		Z		○	○	○	○	○	
	Electro-discharge Machine (EDM)	XY		○	○	○	○	○	
		(Z)			○	○	○	○	
	Wire Cut (EDM)	Y		○	○	○			
UV			○	○	○	○	○		
Punching Press	XY				○	○	○		
Laser Cutting Machine	XY				○	○			
	Z				○	○			
Wood Working Machine					○	○	○	○	
Machines of General use and special Use					○	○	○	○	
Semiconductor Machines	Explosure Equipments		○	○					
	Chemical Treatment					○	○	○	○
	Wire Bonder			○	○	○			
	Prober		○	○	○	○			
	Inserter				○	○	○	○	
PCB Driller			○	○	○	○	○		
Industrial Robots	Orthogonal Type	As'sy		○	○	○	○	○	
		Others					○	○	○
	Multi-joints Type	As'sy			○	○	○		
		Others				○	○	○	
SCARA Type				○	○	○	○		
Machines for Steel molding						○	○	○	
Injection Molding Machines						○	○	○	
Three-Dimensional Measuring Machines			○	○	○				
Business Machines						○	○	○	
Pattern Image Machines			○	○					
Nuclear	Rod Control					○	○	○	
	Mechanical Snubber							○	○
Aircrafts						○	○		

■ 1-8-2 Countermeasure Against Thermal Displacement

Thermal displacement of the screw shaft results in deterioration of the position accuracy. The magnitude of the thermal displacement is calculated as follows :

$$\Delta \ell = \alpha \cdot \Delta t \cdot L$$

$\Delta \ell$: Thermal displacement

α : Coefficient of thermal expansion

Δt : Temperature rise (deg) at screw shaft

L : Effective length of screw thread

Namely, the screw shaft develops elongation of 12 μ m per 1m when the temperature rises by 1°C. The ball screw, which lead has been machined to high accuracy, may fail to meet high level requirements because of the thermal displacement due to temperature rise. As high speed is applied during ball screw usage, the heat will rise as well and cause more influence.

The thermal displacement countermeasures for ball screws include the following :

(1) Control of heat generation

- Optimization of preload
- Correct selection and supply of lubricant
- Increase in ball screw lead, with reduced rotation speed

(2) Forced cooling

- Hollow screw shaft to allow cooling fluid to flow through
- Cooling of screw shaft exterior with cooling oil or air

(3) Avoid influence of temperature rise

Warming up the machine through high speed to attain the stable temperature :

- Operates after the temperature become stable
- Pre-tension on screw shaft
- Preset a negative value on target value of the cumulative lead.
- Use the closed loop for positioning

ABOUT BALL SCREW

1-9 Service Life Design

1-9-1 Service Life of Ball Screws

Even the ball screw is used under correct conditions, it would still fail after a period time of usage. From the beginning to the unusable condition of ball screw, this period of time is called service life of ball screw, which is generally classified into the fatigue life when delamination phenomenon occurs and the accuracy deterioration life caused by wear-out, etc.

1-9-2 Basic Static Load Rating C_{0a}

The basic load rating is an axial load which will produce a permanent deformation at contact points of the steel balls to ball grooves equal to 0.01% of ball diameter.

1-9-3 Basic Dynamic Load Rating C_a

The basic dynamic load rating is an axial load which allow 90% of a group of identical ball screws (rotated under the same condition) to rotate without flaking for 10^6 revolutions. This basic dynamic load rating is shown in the table of dimensions.

Relation between load and service life $L_a = \left(\frac{1}{P}\right)^3$ L : Service life P : Load

1-9-4 Fatigue Life

Average load P_e

(1) When axial load keeps changing, please calculate in order the average load for the equivalent fatigue life under different load condition changes. (see Table 1.9.1)

$$(P_e = \frac{P_1^3 n_1 t_1 + P_2^3 n_2 t_2 + \dots + P_n^3 n_n t_n}{n_1 t_1 + n_2 t_2 + \dots + n_n t_n})^{\frac{1}{3}} \text{ (kgf)})$$

Axial Load (kgf)	Rotating Speed (min ⁻¹)	Time(%)
P1	n1	t1
P2	n2	t2
⋮	⋮	⋮
Pn	nn	tn

But, $t_1 + t_2 + t_3 + \dots + t_n = 100$

Table 1.9.1 Service Life in Different Application.

Usage	Life in hours (h)
Working machines	20000
General industrial machines	10000
Automatic control machines	15000
Measurement machines	15000

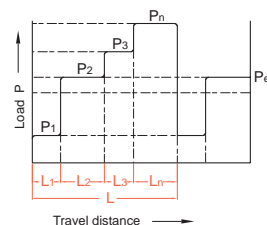

Fig 1.9.1

$$P_e = \frac{2P_{max} + P_{min}}{3} \text{ (kgf)}$$

P_{max} : Maximal axial load (kgf)

P_{min} : Minimal axial load (kgf)

(2) When load changes according to sine curve (see Fig 1.9.2)

$P_e \cong 0.65 P_{max}$ (Fig A)

$P_e \cong 0.75 P_{max}$ (Fig B)

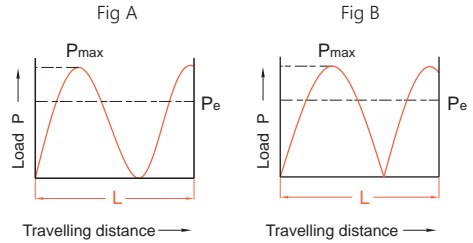

Fig 1.9.2

■ 1-9-5 Calculation of Service Life

The fatigue life is generally expressed by the total number of revolutions. The total rotation hours or total travel distance may also be used to express service life. The fatigue life is calculated as follow :

$$L = \left[\frac{C_a}{P_a \cdot f_w} \right]^3 \cdot 10^6$$

$$L_t = \frac{L}{60n}$$

$$L_s = \frac{L \cdot \ell}{10^6}$$

Where

L : Rated fatigue life (rev)

L_s : Life in travel distance (km)

P_a : Axial load (kgf)

f_w : Load Coefficient

(Required coefficient to operate)

L_t : Life in hours (h)

C_a : Basic dynamic load rating (kgf)

n : Rotating speed (rpm)

ℓ : Lead (mm)

Table 1.9.2 Load Factor (fw)

Vibration and impact	Velocity (V)	f_w
Minor	$V \leq 0.25$ m/s Very Low	1~1.2
Little	$0.25 < V \leq 1$ m/s Low	1.2~1.5
Moderate	$1 < V \leq 2$ m/s Medium	1.5~2
Heavy	$V > 2$ m/s High	2~3.5

Table 1.9.3 Factor of Safety (fs)

Usage	Operation	f_s
Machine tool	Normal operation	1.0 ~ 1.3
	Operation with impact and vibration	2.0 ~ 3.0
Industrial machine	Normal operation	1.0 ~ 1.5
	Operation with impact and vibration	2.5 ~ 7.0

Basic Dynamic Load Rating C_a

$$C_a = P_e \cdot f_s$$

Basic Static Load Rating C_{0a}

$$C_{0a} = P_{max} \cdot f_s$$

ABOUT BALL SCREW

1-9 Life Design

Key Points for Ball Screws Selection

To choose a perfect fit ball screw, users need to understand operating requirement, which is the fundamental principal of deciding the design. Besides, the main factors of selection include load weight, stroke, torque, positioning accuracy in a single time and repeatedly, rigidity, lead and nut's inner diameter. Among all the factors, any single factor's change will cause the change of other factors. Therefore, the balance between all factors is a must to pay attention to.

Calculation for Ball Screws Selection

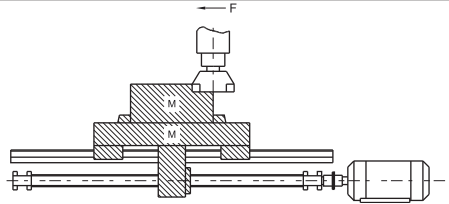

Design conditions

1. Working table weight 300 Kg
2. Working object weight 400 Kg
3. Max Stroke 700 mm
4. Feeding speed 10 m/min
5. Minimal disassembly ability 10μm/stroke
6. Driving motor DC motor (MAX 1000 min)
7. Guiding surface friction coefficient (μ= 0.05~0.1)
8. Running rate 60 %
9. Accuracy review items
10. Inertia generated during acceleration/deceleration can be neglected because the time periods involved are comparatively small.

1. Setting of operation conditions

(a) Machine service life time reckoning of H (hr)

$$H = \left[\text{hours/day} \right] \cdot \left[\text{days/year} \right] \cdot \left[\text{life years} \right] \cdot \left[\text{running rate} \right]$$

(b) Mechanical conditions

Calculation Items / Different Operations	Speed/rotations	Cutting resistance	Sliding resistance	Time used
Fast feed	m/min/min ⁻¹	kgf	kgf	%
Light cutting	/			
Medium cutting	/			
Heavy cutting	/			

(c) Position determination accuracy

Feed accuracy error factor includes load accuracy and system rigidity. Other factors which caused by temperature rise such as heat deformation and mounting accuracy of surface are needed to be considered.

1. Setting of operation conditions

(a) Machine service life time reckoning of H (hr)

$$H = 12 \text{ hr} \cdot 250 \text{ days} \cdot 10 \text{ years} \cdot 0.6 \text{ Running rate} = 18000 \text{ hr}$$

(b) Mechanical conditions

Calculation Items / Different Operations	Speed/rotations	Cutting resistance	Sliding resistance	Time used
Fast feed	10m/min/1000min ⁻¹	0 kgf	70 kgf	10 %
Light cutting	6/600	100	70	50
Medium cutting	2/200	200	70	30
Heavy cutting	1/100	300	70	10

$$\text{Sliding resistance} = (300 + 400) \cdot 0.1 = 70 \text{ kgf}$$

Key Points for Ball Screws Selection	Calculation for Ball Screws Selection
<p>2. Ball screw lead l (mm)</p> $l = \frac{\text{Feeding speed (m/min)} \cdot 1000}{\text{Max. Rotating speed (min}^{-1}\text{) of motor}} \text{ (mm)}$	<p>2. Ball screw lead l (mm)</p> $l = \frac{10000}{1000} = 10 \text{ (mm)}$ <p>Minimal disassembly = $\frac{10 \text{ mm}}{1000 \text{ stroke}}$ = 0.01 mm/stroke</p>
<p>3. Computation of average load P_e (kgf)</p> $P_e = \left[\frac{P_1^3 n_1 t_1 + P_2^3 n_2 t_2 + \dots + P_n^3 n_n t_n}{n_1 t_1 + n_2 t_2 + \dots + n_n t_n} \right]^{\frac{1}{3}}$ $P_e = \frac{2P_{\max} + P_{\min}}{3}$ <p>$P_e \approx 0.65 P_{\max}$ $P_e \approx 0.75 P_{\max}$</p>	<p>3. Computation of average load P_e (kgf)</p> $P_e = \left[\frac{70^3 \cdot 1000 \cdot 10 + 170^3 \cdot 600 \cdot 50 + 270^3 \cdot 200 \cdot 30 + 370^3 \cdot 100 \cdot 10}{1000 \cdot 10 + 600 \cdot 50 + 200 \cdot 30 + 100 \cdot 10} \right]^{\frac{1}{3}}$ $= \left[\frac{31.7 \cdot 10^{10}}{4.7 \cdot 10^4} \right]^{\frac{1}{3}}$ <p>$\approx 189 \text{ kgf}$</p>
<p>4. Average number of rotations n_m</p> $n_m = \frac{n_1 t_1 + n_2 t_2 + \dots + n_n t_n}{100}$	<p>4. Average number of rotations n_m</p> $n_m = \frac{1000 \cdot 10 + 600 \cdot 50 + 200 \cdot 30 + 100 \cdot 10}{100}$ $= \frac{4.7 \cdot 10^4}{100} = 470 \text{ min}^{-1}$
<p>5. Calculation of required dynamic rated load C_a</p> $C_a = P_e \cdot f_s$	<p>5. Calculation of required dynamic rated load C_a</p> $C_a = 189 \cdot 5 = 945 \text{ (kgf)}$
<p>6. Calculation of required static rated load C_{0a}</p> $C_{0a} = P_{\max} \cdot f_s$	<p>6. Calculation of required static rated load C_{0a}</p> $C_{0a} = 369 \cdot 5 = 1845 \text{ (kgf)}$
<p>7. Selection of nut type</p> <p>$C_a > 945$ $C_{0a} > 1845$ Select the nut types with basic dynamic rated load and basic static rated load as specified above.</p>	<p>7. Selection of nut type</p> <p>Choose SFNI 2510 on the catalogue $C_a = 2954 \text{ (kgf)}$ $C_{0a} = 7295 \text{ (kgf)}$</p>

ABOUT BALL SCREW

1-9 Life Design

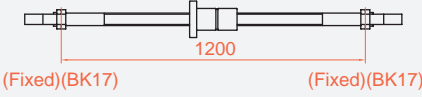
Key Points for Ball Screws Selection	Calculation for Ball Screws Selection
<p>8. Calculation of service life L_t (h)</p> $L_t = \frac{L}{60n} = \left(\frac{C_a}{P_e \cdot f_w} \right)^3 \cdot 10^6 \cdot \frac{1}{60n}$	<p>8. Calculation of service life L_t (h)</p> $L_t = \left(\frac{2954}{189 \cdot 2} \right)^3 \cdot 10^6 \cdot \frac{1}{60 \cdot 470} = 42544(\text{h})$
<p>9. Mounting distance between supporting bearings</p>	<p>9. Mounting distance between supporting bearings</p> 
<p>10. Determination of screw length</p> <p>Screw length = Maximal stroke + Nut length + Two reserved length at shaft end</p>	<p>10. Determination of screw length</p> <p>Screw length = 700 + 85 + 76 + 76 = 937 mm 937 mm < 1200 mm</p>
<p>11. Permissible axial load</p>	<p>11. Permissible axial load</p> <p>Omitted because of F-F support</p>
<p>12. Permissible revolution speed n and DN</p> $n = \alpha \cdot \frac{60\lambda^2}{2\pi L^2} \sqrt{\frac{E\lambda g}{\gamma A}} = f \frac{dr}{L^2} \cdot 10^7 (\text{rpm})$ <p>DN = Shaft dia · Maximal speed</p>	<p>12. Permissible revolution speed n and DN</p> $n = \frac{21.9 \cdot 21.86 \cdot 10^7}{1200^2} = 3324 \text{ min}^{-1} < n_{\text{max}}$ <p>DN = 25 · 1000 = 25000 < 50000</p>
<p>13. Countermeasure against thermal displacement</p> $\Delta l = \alpha \cdot \Delta t \cdot L$ <p>Δl: Thermal displacement α: Coefficient of thermal expansion Δt: Temperature rise (deg) at screw shaft L: Effective length of screw thread</p>	<p>13. Countermeasure against thermal displacement</p> <p>It is estimated there would be a temperature rise 2~5°C with the ball screws of the general machinery, take temperature rise of 2°C to the extension of ball screw.</p> $\Delta l = \alpha \cdot \Delta t \cdot L = 11.7 \cdot 10 \cdot 2 \cdot 700 \text{ mm}$ $\approx 0.016 \text{ mm}$ $F_p = \frac{EA \Delta l}{L}$ $= \frac{2.06 \cdot 10^4 \cdot \pi \cdot 21.86^2 \cdot 0.016}{700}$ $\approx 177 (\text{kgf})$

Key Points for Ball Screws Selection	Calculation for Ball Screws Selection
<p>14. Rigidity</p> <p>(1) Axial rigidity K_s and displacement δ_s of screw shaft</p> $K_s = \frac{P}{\delta_s} \text{ (kgf/mm)}$ <p>P : Axial load (kgf)</p> $\delta_{SF} = \frac{PL}{4AE} \text{ (mm)} \dots\dots \text{(with reference to page C21)}$ <p>(2) Axial rigidity K_N and displacement δ_s of nut</p> $\delta_{NS} = \frac{K}{\sin\beta} \left[\frac{Q^2}{d} \right]^{\frac{1}{3}} \cdot \frac{1}{\xi} \text{ (mm)}$ $Q = \frac{P}{n \cdot \sin\beta} \text{ (kgf)}$ $n = \frac{D_0 \pi m}{d} \text{ (each)} \dots\dots \text{(with reference to page C22)}$ <p>(3) Axial rigidity K_B and displacement δ_B of bracing shaft</p> $K_B = \frac{P}{\delta_B} \text{ (kgf/mm)} \dots\dots \text{(with reference to page C23)}$	<p>14. Rigidity</p> <p>Deviation can be corrected by estimating the temperature rise per extension of 0.016 mm, and taking into consideration of the pre-tension of 177 kgf.</p> <p>(1) Directional rigidity</p> $\delta_{SF} = \frac{PL}{4AE} = \frac{27 \cdot 1200}{4 \cdot \pi \cdot 21.86^2 \cdot 2.06 \cdot 10^4}$ $= 0.00105 \text{ (mm)}$ $K_s = \frac{370}{0.00105} = 3.5 \cdot 10^5 \text{ kgf/mm}$ <p>(2) Rigidity of steel ball and nut groove</p> $n = \frac{26.62 \cdot \pi \cdot 4}{4.762} = 70$ $Q = \frac{370}{70 \sin 45^\circ} = 10$ $\delta_{NS} = \frac{0.00057}{\sin 45^\circ} \left(\frac{10^2}{4.762} \right)^{\frac{1}{3}} \cdot \frac{1}{0.7}$ $= 3.2 \cdot 10 \text{ mm}$ $K_N = \frac{370}{3.2 \cdot 10^{-3}} = 1.27 \cdot 10^5 \text{ kgf/mm}$ <p>(3) Rigidity of support bearings</p> <p>Where, nut rigidity 50 kgf/μm</p> $\delta_B = \frac{370}{51 \cdot 2} = 3.6 \mu\text{m}$ $K_B = \frac{370}{0.0036} = 1 \cdot 10^5 \text{ kgf/mm}$ <ul style="list-style-type: none"> • $\delta_{TOTAL} = 1.05 + 3.2 + 3.6 = 7.85 \mu\text{m}$
<p>15. Confirmation of the ball screw life</p>	<p>15. Confirmation of the ball screw life</p> $L = 42544 \text{ (h)} > 18000 \text{ (h)}$

ABOUT BALL SCREW

1-10 Cautions About Use of Ball Screws

Ball screw assemblies are delicate components. Therefore, extra care must be taken to prevent the ball track from damages that caused by edged component or tools. Meanwhile, to prevent steel ball fall out of the nut through the disassembly of screw and nut or over stroke, please be careful while operating. If the steel ball falls out, please contact with TBI MOTION for further instruction. Do not attempt to reassemble, which might cause permanent damage to the ball screw.)

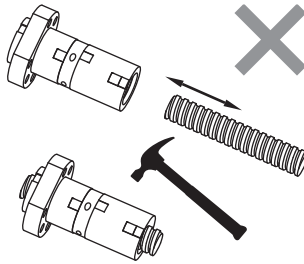

Fig 1.10.1 Error installation

If disassemble is required, please use a transfer pipe which has minor diameter than the screw diameter to transfer the nut to prevent falling out of the steel balls.

■ 1-10-1 Lubrication

Adequate lubrication must be provided when ball screw is used, insufficient lubrication will result in collision of metal, which leads to increase of friction and detrition, thus cause failure or shortening the service life.

Lubricants applied to ball screws can be divided into 2 types, namely lubricating oil and consistent grease. In general speaking, in respect of maintenance, consistent grease will lead to increase of dynamic friction torque linearly along with increase of rotating speed, hence oil lubrication is deemed the better way when speed exceeds 3-5 m/min; however, don't forget the fact that there have been examples that using grease has been capable of achieving speed of 10 m/min, with respect to the equipment.

In terms of equipments, there are some cheaper lubricant that can be used. In general, to fully utilize the function of ball screw, lubricating oil of 5m/minute is the best option to choose. In figure 1.10.1, we provide the standard of lubricating oil inspection and supplement interval. Before replenishing, please clean up the previous grease to continue.

Table 1.10.1 Inspection of lubrication and interval of refill

Method	Interval	Check Item	Replenish or Change Interval
Auto. Periodial oil supply	Weekly	Oil level, contamination	Add at each check, as required depending on tank level
Grease	Initially 2~3 months	Contamination on entry of chip	replenish yearly or according to the inspection result.
Oil bath	Daily	Oil level	To be determined according to consumption

■ 1-10-2 Dust Proof / Prevention

Any foreign matter or water, if entering to the ball screw, may increase friction and cause damage. For example, the entry of chips or cutting oil may be expected with machine tools according to the work environment. Where entry of foreign matter is anticipated, use a bellows or telescopic cover as shown in Fig 1.10.2, to cover the screw shaft completely.

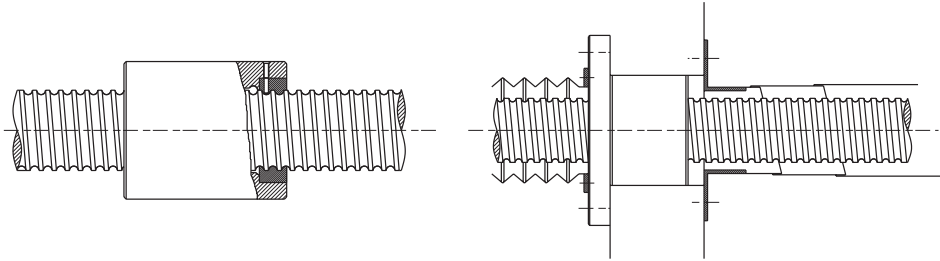

Fig 1.10.2 Dust proof Method by Telescopic Cover and Bellows

■ 1-10-3 Offset Load

When offset load phenomenon occurs, screw life and noise tend to be directly affected, which would usually be accompanied with hand feel of rough running. As the smoothness of single shaft and assembled ball screw might be different. In addition to single shaft's accuracy, the offset phenomenon was mostly occurred by failed assemble accuracy which is shown in Fig 1.10.3.

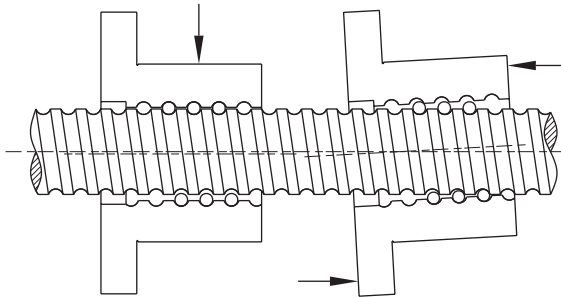

Fig 1.10.3 Offset Load

ABOUT BALL SCREW

1-10 Cautions About Use of Ball Screws

■ 1-10-4 Assembling the Ball Screws

If rolled ball nut is shipped un-assembled please follow the procedure as below.

Table 1.10.2 Procedure

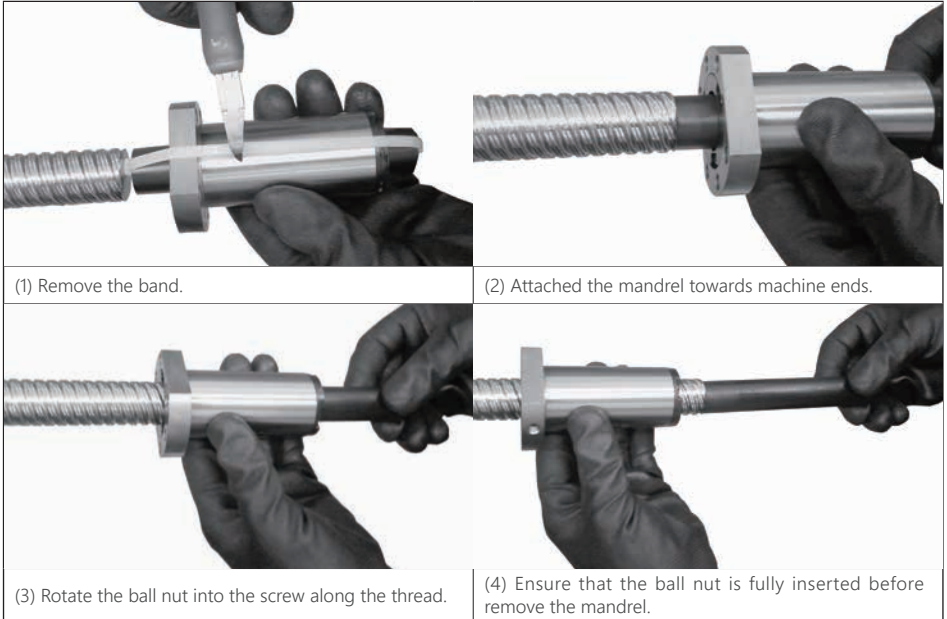

■ 1-10-5 Machining Specifications

(1) For the Ball Screws with internal or end cap type circulation ball nut, it is required to have at least one end with complete thread to the end of screw, it is also required to have the journal area is with diameter to be smaller than the diameter of thread root as Fig 1.10.4 shown.

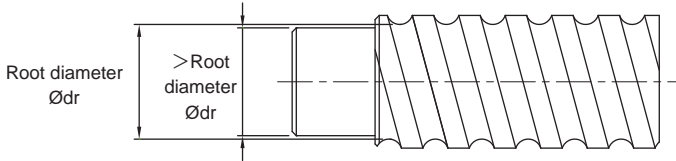

Fig 1.10.4 For Internal Circulation

(2) The thread on screw shaft are hardened by induction hardening. It shall cause about 10~20mm at both ends journal purpose. The unhardened area will be labeled.

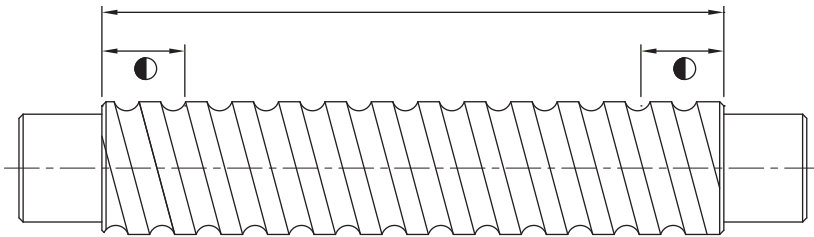

Fig 1.10.5 Harden Area

TBI MOTION BALL SCREW

2-1 Nominal Model Code of Ball Screw

SFU R 025 05 T4 D G C5 - 600 - P1 - B2 + N3 N3

① ② ③ ④ ⑤ ⑥ ⑦ ⑧ ⑨ ⑩ ⑪ ⑫ ⑬

①	②	⑤	⑦
Nominal Model	Threading Direction	Number of Turns (Turn-Row)	Product Code
S : Single nut	R : Right	Turn : T : 1	G : Ground
D : Double nut	L : Left	A : 1.5 (or 1.7/1.8)	F : Rolled
O : OFF set double nut		B : 2.5/2.8	
F : With flange	③	C : 3.5	⑧
C : Without flange	Nominal Diameter	D : 4.8	Accuracy Grade
NI : NI type nut	Unit : mm	ex : (2.5 × 2 = B2)	C0, C1, C2, C3, C5, C7, C10
NU : NU type nut			
H : H type nut	④	⑥	⑨
NH : NH nut (A solution for slide table)	Lead	Flange Type	Overall Length of Shaft
Y : Y type nut	Unit : mm	N : Not cutting	Unit : mm
V : V type nut		S : Single cutting	
U : DIN nut		D : Double cutting	
M : M type nut			
K : K type nut			

⑩	⑪
Axial Clearance and Preload Value	Number of Nut
P0, P1, P2, P3, P4	(Leave blank if only one nut is required) Ex : Install two nuts on a shaft B2

⑫	⑬
Nut Surface Treatment	Shaft Surface Treatment
S : Standard	S : Standard
B1 : Black Oxidation	B1 : Black Oxidation
N1 : Hard Chrome Plating	N1 : Hard Chrome Plating
P : Phosphating	P : Phosphating
N3 : Nickel Plating	N3 : Nickel Plating
N4 : Raydent	N4 : Raydent
N5 : Chrome Plating	N5 : Chrome Plating

※ No symbol required when plating is not needed.

※ An inspection report is provided for ground ball screws with an accuracy higher than C5.

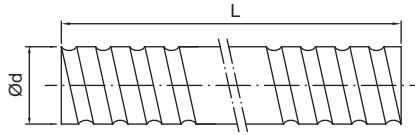

Fig 2.1.1 Screw Shaft Nominal Diameter

Table 2.1.1 Ground Ball Screw Specifications Ø4~32

Model No.			Accuracy Grade	Threading Direction	Number of Grooves	Standard Code of Shaft	Type of Nut
Ød	I	Da		R : Right L : Left			
4	1	0.8	C7, C5, C3	R	1	SCR00401	K
6	1	0.8	C7, C5, C3	R	1	SCR00601	K
8	1	0.8	C7, C5, C3	R/L	1	SCR00801	K
	2	1.2	C7, C5, C3	R/L	1	SCR00802	K
	2.5	1.2	C7, C5, C3	R	1	SCR0082.5	K, BSH
10	2	1.2	C7, C5, C3	R/L	1	SCR01002	K, BSH
	4	2	C7, C5, C3	R	1	SCR01004	K, BSH
12	2	1.2	C7, C5, C3	R/L	1	SCR01202	K
	4	2.5	C7, C5, C3	R	1	SCR01204	U, BSH
	5	2.5	C7, C5, C3	R	1	SCR01205-A	V, U, BSH, H
	10	2.5	C7, C5, C3	R	2	SCR01210-B	V
14	2	1.2	C7, C5, C3	R/L	1	SCR01402	K
	4	2.5	C7, C5, C3	R	1	SCR01404	BSH
16	2	1.2	C7, C5, C3	R/L	1	SCR01602	K
	4	2.381	C7, C5, C3	R	1	SCR01604(N)	V, I, U, BSH
	5	3.175	C7, C5, C3	R/L	1	SCR01605	V, NI, NU, BSH
	10	3.175	C7, C5, C3	R/L	2	SCR01610	V, NI, NU, BSH
	16	2.778	C7, C5, C3	R	2	SCR01616	Y
20	32	2.778	C7, C5, C3	R	2	SCR01632	Y
	4	2.381	C7, C5, C3	R	1	SCR02004(N)	V, I, U
	5	3.175	C7, C5, C3	R/L	1	SCR02005	V, NI, NU, BSH, H
	10	3.969	C7, C5, C3	R	1	SCR02010	V
	20	3.175	C7, C5, C3	R	2	SCR02020	V, Y, H
25	40	3.175	C7, C5, C3	R	2	SCR02040	Y
	4	2.381	C7, C5, C3	R	1	SCR02504(N)	I, U
	5	3.175	C7, C5, C3	R/L	1	SCR02505	V, NI, NU, BSH, H
	6	3.969	C7, C5, C3	R	1	SCR02506	V, U
	8	4.762	C7, C5, C3	R	1	SCR02508	V, U
	10	4.762	C7, C5, C3	R	1	SCR02510-A	NI, NU, BSH
	10	6.35	C7, C5, C3	R	1	SCR02510-B	V
	25	3.969	C7, C5, C3	R	2	SCR02525	Y
32	50	3.969	C7, C5, C3	R	2	SCR02550	Y
	4	2.381	C7, C5, C3	R	1	SCR03204(N)	V, I, U
	5	3.175	C7, C5, C3	R/L	1	SCR03205	V, NI, NU, M, H
	6	3.969	C7, C5, C3	R	1	SCR03206	V, U
	8	4.762	C7, C5, C3	R	1	SCR03208	V, U
	10	6.35	C7, C5, C3	R/L	1	SCR03210	V, NI, NU
	20	6.35	C7, C5, C3	R	1	SCR03220	V
	32	4.762	C7, C5, C3	R	2	SCR03232	Y
64	4.762	C7, C5, C3	R	2	SCR03264	Y	

TBI MOTION BALL SCREW

2-1 Nominal Model Code of Ball Screw

Table 2.1.2 Standard Specifications Ø40~80

Unit : mm

Ød	Model No.		Accuracy Grade	Threading Direction R : Right L : Left	Number of Grooves	Standard Code of Shaft	Type of Nut
	I	Da					
40	5	3.175	C7, C5, C3	R / L	1	SCR04005	V, NI, NU, H
	6	3.969	C7, C5, C3	R	1	SCR04006	V, NU
	8	4.762	C7, C5, C3	R	1	SCR04008	V, NU
	10	6.35	C7, C5, C3	R / L	1	SCR04010	V, NI, NU
	20	6.35	C7, C5, C3	R	2	SCR04020	V
	40	6.35	C7, C5, C3	R	2	SCR04040	Y
	80	6.35	C7, C5, C3	R	2	SCR04080	Y
50	5	3.175	C7, C5, C3	R	1	SCR05005	V, H
	10	6.35	C7, C5, C3	R / L	1	SCR05010	V, NI, NU
	20	9.525	C7, C5, C3	R	1	SCR05020	V
	50	7.938	C7, C5, C3	R	2	SCR05050	Y
	100	7.938	C7, C5, C3	R	2	SCR050100	Y
63	10	6.35	C7, C5, C3	R	1	SCR06310	V, NI, NU
	20	9.525	C7, C5, C3	R	1	SCR06320	V, NU
80	10	6.35	C7, C5, C3	R	1	SCR08010	V, NI, NU
	20	9.525	C7, C5, C3	R	1	SCR08020	V, NU

Table 2.1.3 H-type Specifications Ø16~50

Unit : mm

Ød	Model No.		Accuracy Grade	Threading Direction R : Right L : Left	Number of Grooves	Type-H Code of Shaft	Type of Nut
	I	Da					
12	10	2.5	C7, C5, C3	R	1	SSR01210	H
16	5	2.778	C7, C5, C3	R	1	SSR01605	H
	10	2.778	C7, C5, C3	R	1	SSR01610	H
	16	2.778	C7, C5, C3	R	1	SSR01616	H
	20	2.778	C7, C5, C3	R	1	SSR01620	H
	20	10	3.175	C7, C5, C3	R	1	SSR02010
25	10	3.175	C7, C5, C3	R	1	SSR02510	H
	25	3.175	C7, C5, C3	R	1	SSR02525	H
32	10	3.969	C7, C5, C3	R	1	SSR03210	H
	20	3.969	C7, C5, C3	R	1	SSR03220	H
	32	6.35	C7, C5, C3	R	1	SSR03232	H
40	10	6.35	C7, C5, C3	R	1	SSR04010	H
	20	6.35	C7, C5, C3	R	1	SSR04020	H
	40	6.35	C7, C5, C3	R	1	SSR04040	H
50	10	6.35	C7, C5, C3	R	1	SSR05010	H
	20	6.35	C7, C5, C3	R	1	SSR05020	H
	50	6.35	C7, C5, C3	R	1	SSR05050	H

※ The information is for specifications, if customized products are needed please contact **TBI MOTION**.

2-2 Precision Ground Ball Screw Series

2-2-1 TBI MOTION Nut of Precision Ground Ball Screw Type

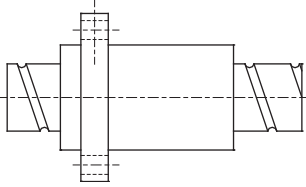
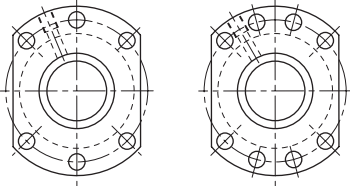
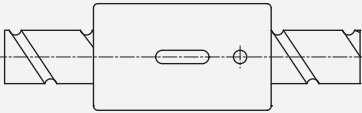
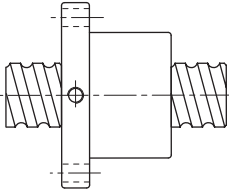
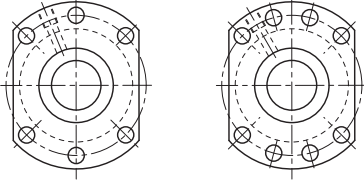
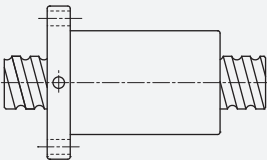
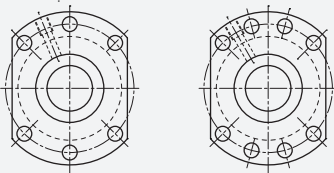
	Nut Type	Flange Type
NH/H (A solution for slide table/High Speed/Strong dust-proof type)	<p>SFNH/SFH (DIN)</p>  <p>C44</p>	 <p>$d \leq 32$ $d \geq 40$</p>
CNH (A solution for slide table)	<p>SCNH</p>  <p>C45</p>	No-Flange
NU/U (Strong dust-proof type)	<p>SFNU/SFU (DIN)</p>  <p>C46</p>	 <p>$d \leq 32$ $d \geq 40$</p>
OFU/U (OFF set double nut)	<p>OFU/DFU (DIN)</p>  <p>C47</p>	

TBI MOTION BALL SCREW

2-2 Precision Ground Ball Screw Series

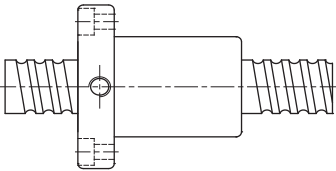
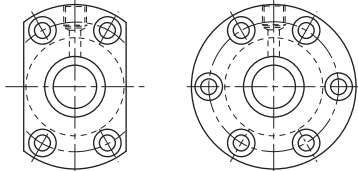
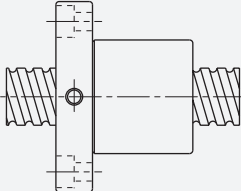
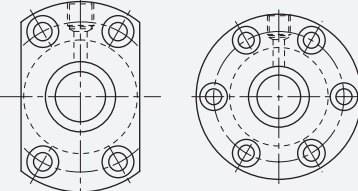
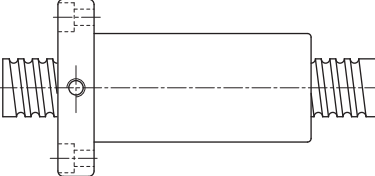
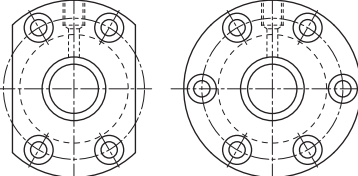
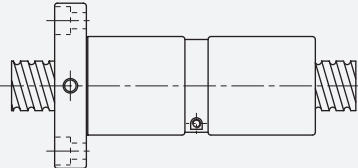
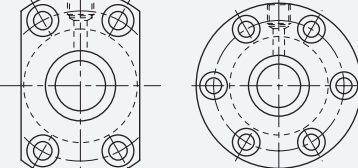
	Nut Type	Flange Type
NI/I (Strong dust-proof type)	<p>SFNI/SFI</p>  <p>C48</p>	
M (Design for Milling)	<p>SFM</p>  <p>C48</p>	
OFI/I (OFF set double nut)	<p>OFI/DFI</p>  <p>C49</p>	
M (Design for Milling)	<p>DFM</p>  <p>C49</p>	

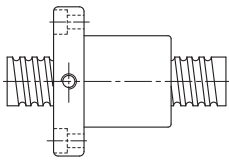
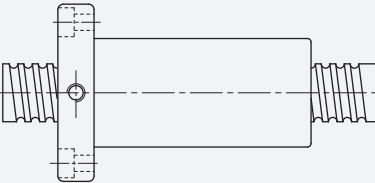
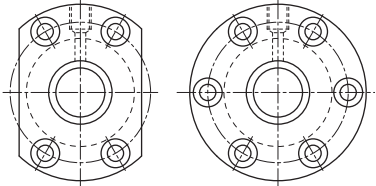
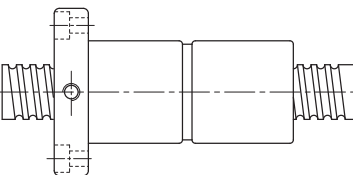
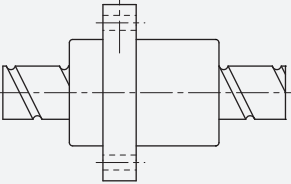
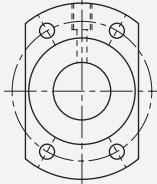
	Nut Type	Flange Type
<p>> (High Load External Circulation type)</p>	<p>SFV</p>  <p>C50</p>	
<p>OFV (OFF set double nut)</p>	<p>OFV</p>  <p>C51</p>	
<p>> (High Load External Circulation type)</p>	<p>DFV</p>  <p>C51</p>	
<p>> (High DM-N Rating)</p>	<p>SFY</p>  <p>C52</p>	

TBI MOTION BALL SCREW

2-2 Precision Ground Ball Screw Series

C
Ball Screw

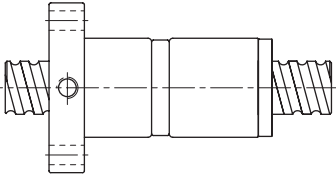
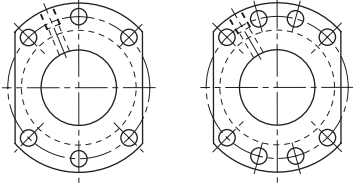
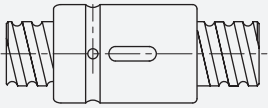
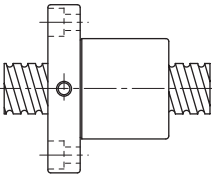
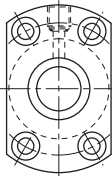
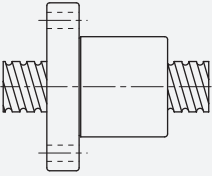
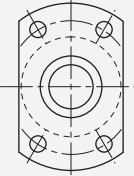
	Nut Type	Flange Type
S (High Speed / Low Noise type)	<p>DFS (DIN)</p>  <p>C53</p>	 <p>Model No. ≤3232 Model No. ≥4005</p>
	<p>CNI/1</p> <p>(Standard)</p> <p>SCNI/SCI</p>  <p>C54</p>	<p>No-Flange</p>
K (Miniature type)	<p>SFK</p>  <p>C55</p>	 <p>(SFK 01004) (SFK 02002) (SFK 02502)</p>
	<p>SFK</p>  <p>C55</p>	

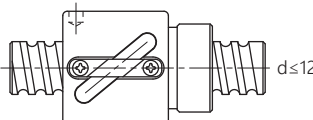
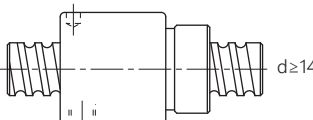
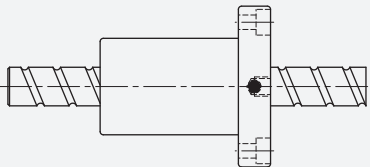
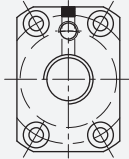
Nut Type		Flange Type
BSH	<p>BSH</p>  <p>$d \leq 12$</p>  <p>$d \geq 14$</p>	No-Flange
	C56	
XSV (Design for factory automation)	<p>XSV</p>  <p>C57~61</p>	

※ The information is for specifications, if customized products are needed please contact **TBI MOTION**.

Table 2.2.1 Preload Chart

Preload	I, U, M-type	H-type	Y-type	V-type	BSH-type	K-type
P0						
P1	√	√	√	√	√	√
P2	√	√	√	√	√	
P3	√	√	√	√	√	
P4				√		

TBI MOTION BALL SCREW

2-2 Precision Ground Ball Screw Series

SFNH/SFH (DIN 69051 FORM B) Series Specifications

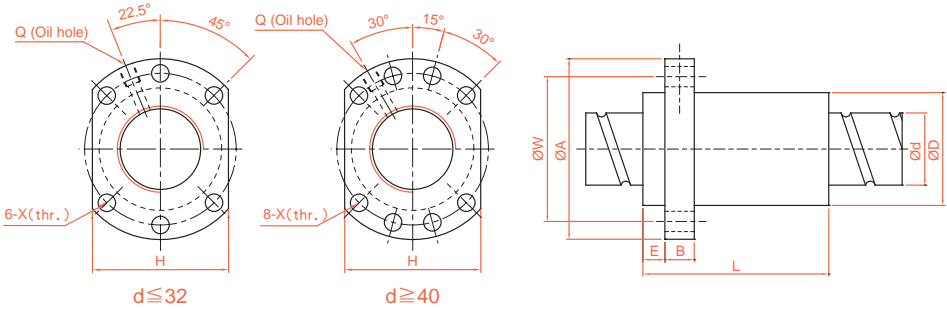

Unit : mm

Model No.	d	I	Da	Dimension										Load Rating		K kgf/μm
				D	A	E	B	L	W	H	X	Q	n	Ca (kgf)	Coa (kgf)	
SFH01205-2.8 *	12	5	2.5	24	40	5	10	30	32	30	4.5		2.8x1	661	1316	19
SFH01210-2.8 *		10	2.5	24	40	5	10	45	32	30	4.5		2.8x1	642	1287	19
SFH01605-3.8 *	15	5	2.778	28	48	5	10	37	38	40	5.5	M6	3.8x1	1112	2507	30
SFH01610-2.8 *		10	2.778	28	48	5	10	45	38	40	5.5	M6	2.8x1	839	1821	23
SFH01616-1.8 *		16	2.778	28	48	5	10	45	38	40	5.5	M6	1.8x1	552	1137	14
SFH01616-2.8 *		16	2.778	28	48	5	10	61	38	40	5.5	M6	2.8x1	808	1769	22
SFH01620-1.8 *	20	20	2.778	28	48	7	10	58	38	40	5.5	M6	1.8x1	554	1170	14
SFH02005-3.8 *		5	3.175	36	58	7	10	37	47	44	6.6	M6	3.8x1	1484	3681	37
SFH02010-3.8 *	20	10	3.175	36	58	7	10	55	47	44	6.6	M6	3.8x1	1516	3833	40
SFH02020-1.8 *		20	3.175	36	58	7	10	54	47	44	6.6	M6	1.8x1	764	1758	19
SFH02020-2.8 *		20	3.175	36	58	7	10	74	47	44	6.6	M6	2.8x1	1118	2734	29
SFH02505-3.8 *		5	3.175	40	62	7	10	37	51	48	6.6	M6	3.8x1	1650	4658	43
SFH02510-3.8 *	25	10	3.175	40	62	7	12	55	51	48	6.6	M6	3.8x1	1638	4633	45
SFH02525-1.8 *		25	3.175	40	62	7	12	64	51	48	6.6	M6	1.8x1	843	2199	22
SFH02525-2.8 *		25	3.175	40	62	7	12	89	51	48	6.6	M6	2.8x1	1232	3421	34
SFH03205-3.8	32	5	3.175	50	80	9	12	37	65	62	9	M6	3.8x1	1839	6026	51
SFH03210-3.8		10	3.969	50	80	9	12	57	65	62	9	M6	3.8x1	2460	7255	55
SFH03220-2.8		20	3.969	50	80	9	12	76	65	62	9	M6	2.8x1	1907	5482	43
SFH03232-1.8		32	3.969	50	80	9	12	80	65	62	9	M6	1.8x1	1257	3426	27
SFH03232-2.8	32	32	3.969	50	80	9	12	112	65	62	9	M6	2.8x1	1838	5329	42
SFH04005-3.8		40	5	3.175	63	93	9	15	42	78	70	9	M8	3.8x1	2018	7589
SFH04010-3.8	38	10	6.35	63	93	9	14	60	78	70	9	M8	3.8x1	5035	13943	67
SFH04020-2.8		20	6.35	63	93	9	14	80	78	70	9	M8	2.8x1	3959	10715	54
SFH04040-1.8		40	6.35	63	93	9	14	98	78	70	9	M8	1.8x1	2585	6648	34
SFH04040-2.8		40	6.35	63	93	9	14	138	78	70	9	M8	2.8x1	3780	10341	52
SFH05005-3.8	50	5	3.175	75	110	10.5	15	42	93	85	11	M8	3.8x1	2207	9542	68
SFH05010-3.8		10	6.35	75	110	10.5	18	60	93	85	11	M8	3.8x1	5638	17852	79
SFH05020-3.8	48	20	6.35	75	110	10.5	18	100	93	85	11	M8	3.8x1	5749	18485	87
SFH05050-1.8		50	6.35	75	110	10.5	18	120	93	85	11	M8	1.8x1	2946	8749	42
SFH05050-2.8		50	6.35	75	110	10.5	18	170	93	85	11	M8	2.8x1	4308	13610	65

※ ★ Actuator type available (SFNH series).

SCNH Series Specifications

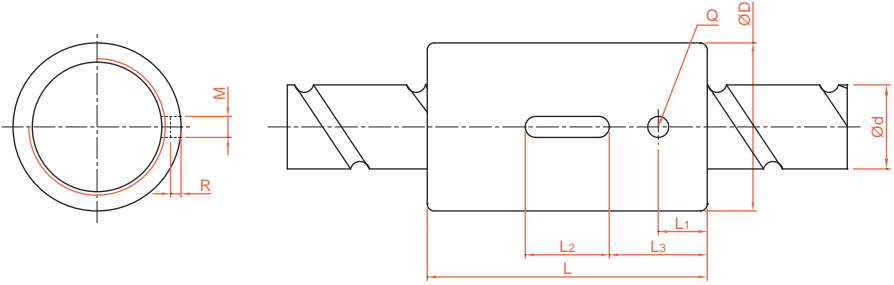

Unit : mm

Model No.	d	I	Da	Dimension										Load Rating		K kgf/μm
				D	L	L1	L2	L3	M	R	Q	n	Ca (kgf)	Coa (kgf)		
SCNH01205-4.8	12	5	2.5	24	40	7	12	14	3	1.5	3	4.8x1	1011	2105	34	
SCNH01210-2.8		10	2.5	24	45	8	15	15	3	1.5	3	2.8x1	642	1287	19	
XCNH01210-1.8		10	2.5	24	40	10.5	12	14	3	1.5	3	1.8x1	439	827	33	
SCNH01605-5.8	15	5	2.778	28	45	7	20	12.5	5	3	3	5.8x1	1599	3827	49	
SCNH01610-2.8		10	2.778	28	45	7	20	12.5	5	3	3	2.8x1	839	1821	23	
SCNH01616-1.8		16	2.778	28	45	7	20	12.5	5	3	3	1.8x1	552	1137	18	
SCNH01620-1.8		20	2.778	28	58	10	20	19	5	3	3	1.8x1	554	1170	14	
SCNH02005-5.8	20	5	3.175	36	47	8	20	13.5	5	3	3	5.8x1	2134	5619	60	
SCNH02010-3.8		10	3.175	36	55	8	20	17.5	5	3	3	3.8x1	1516	3833	40	
SCNH02020-1.8		20	3.175	36	55	8	20	17.5	5	3	3	1.8x1	764	1758	19	

TBI MOTION BALL SCREW

2-2 Precision Ground Ball Screw Series

SFNU/SFU (DIN 69051 FORM B) Series Specifications

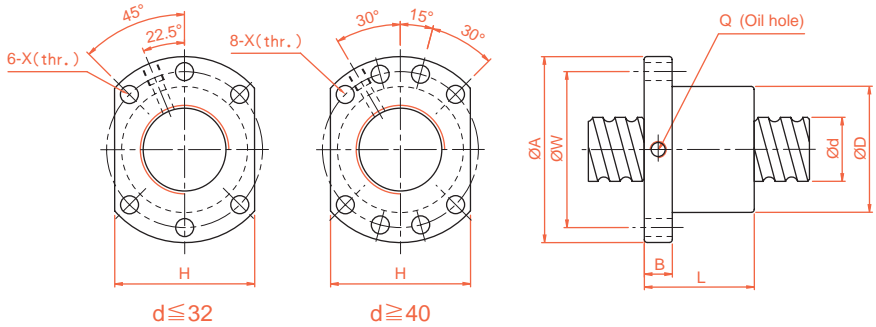

Unit : mm

Model No.	d	I	Da	Dimension									Load Rating		K kgf/μm
				D	A	B	L	W	H	X	Q	n	Ca (kgf)	Coa (kgf)	
SFNU01605-4*	16	5	3.175	28	48	10	45	38	40	5.5	M6	1x4	1380	3052	32
SFNU01610-3*		10	3.175	28	48	10	57	38	40	5.5	M6	1x3	1103	2401	26
SFNU02005-4*	20	5	3.175	36	58	10	51	47	44	6.6	M6	1x4	1551	3875	39
SFNU02505-4*	25	5	3.175	40	62	10	51	51	48	6.6	M6	1x4	1724	4904	45
SFNU02510-4*		10	4.762	40	62	12	80	51	48	6.6	M6	1x4	2954	7295	50
SFNU03205-4*	32	5	3.175	50	80	12	52	65	62	9	M6	1x4	1922	6343	54
SFNU03210-4*		10	6.35	50	80	12	85	65	62	9	M6	1x4	4805	12208	61
SFNU04005-4*	40	5	3.175	63	93	14	55	78	70	9	M8	1x4	2110	7988	63
SFNU04010-4*		10	6.35	63	93	14	88	78	70	9	M8	1x4	5399	15500	73
SFNU05010-4*	50	10	6.35	75	110	16	88	93	85	11	M8	1x4	6004	19614	85
SFNU06310-4*	63	10	6.35	90	125	18	93	108	95	11	M8	1x4	6719	25358	99
SFNU08010-4*	80	10	6.35	105	145	20	93	125	110	13.5	M8	1x4	7346	31953	109
SFU01204-4	12	4	2.5	24	40	10	40	32	30	4.5		1x4	902	1884	26
SFU01604-4	16	4	2.381	28	48	10	40	38	40	5.5	M6	1x4	973	2406	32
SFU02004-4	20	4	2.381	36	58	10	42	47	44	6.6	M6	1x4	1066	2987	38
SFU02504-4	25	4	2.381	40	62	10	42	51	48	6.6	M6	1x4	1180	3795	43
SFU02506-4		6	3.969	40	62	10	54	51	48	6.6	M6	1x4	2318	6057	47
SFU02508-4		8	4.762	40	62	10	63	51	48	6.6	M6	1x4	2963	7313	49
SFU03204-4	32	4	2.381	50	80	12	44	65	62	9	M6	1x4	1296	4838	51
SFU03206-4		6	3.969	50	80	12	57	65	62	9	M6	1x4	2632	7979	57
SFU03208-4		8	4.762	50	80	12	65	65	62	9	M6	1x4	3387	9622	60
SFU04006-4	40	6	3.969	63	93	14	60	78	70	9	M6	1x4	2873	9913	66
SFU04008-4		8	4.762	63	93	14	67	78	70	9	M6	1x4	3712	11947	70
SFU05020-4	50	20	7.144	75	110	16	138	93	85	11	M8	1x4	7142	22588	94
SFU06320-4	63	20	9.525	95	135	20	149	115	100	13.5	M8	1x4	11444	36653	112
SFU08020-4	80	20	9.525	125	165	25	154	145	130	13.5	M8	1x4	12911	47747	138
SFU10020-4	100	20	9.525	150	202	30	180	170	155	17.5	M8	1x4	14303	60698	162

※ ☆ Left helix available

OFU/DFU (DIN 69051 FORM B) Series Specifications

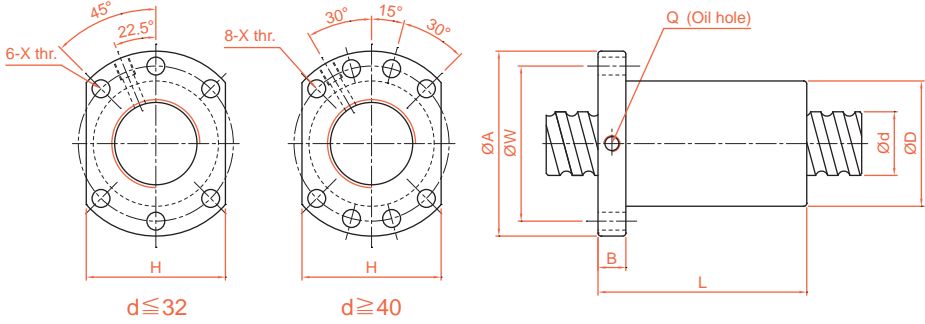

Unit : mm

Model No.	d	I	Da	Dimension								Load Rating		K kgf/μm	
				D	A	B	L	W	H	X	Q	n	Ca (kgf)		Coa (kgf)
OFU01605-4	16	5	3.175	28	48	10	75	38	40	5.5	M6	1x8	1380	3052	44
OFU02005-4	20	5	3.175	36	58	10	85	47	44	6.6	M6	1x8	1551	3875	53
OFU02505-4	25	5	3.175	40	62	10	86	51	48	6.6	M6	1x8	1724	4904	62
OFU02510-4		10	4.762	40	62	12	130	51	48	6.6	M6	1x8	2954	7295	67
OFU03205-4	32	5	3.175	50	80	12	87	65	62	9	M6	1x8	1922	6343	74
OFU03210-4		10	6.35	50	80	12	145	65	62	9	M6	1x8	4805	12208	82
OFU04005-4	40	5	3.175	63	93	14	90	78	70	9	M8	1x8	2110	7988	87
OFU04010-4		10	6.35	63	93	14	148	78	70	9	M8	1x8	5399	15500	99
OFU05010-4	50	10	6.35	75	110	16	148	93	85	11	M8	1x8	6004	19614	117
OFU06310-4	63	10	6.35	90	125	18	153	108	95	11	M8	1x8	6719	25358	139
OFU08010-4	80	10	6.35	105	145	20	153	125	110	13.5	M8	1x8	7346	31953	156
DFU01604-4	16	4	2.381	28	48	10	80	38	40	5.5	M6	1x4	973	2406	43
DFU02004-4	20	4	2.381	36	58	10	80	47	44	6.6	M6	1x4	1066	2987	51
DFU02504-4	25	4	2.381	40	62	10	80	51	48	6.6	M6	1x4	1180	3795	60
DFU02506-4		6	3.969	40	62	10	105	51	48	6.6	M6	1x4	2318	6057	64
DFU02508-4		8	4.762	40	62	10	120	51	48	6.6	M6	1x4	2963	7313	67
DFU03204-4	32	4	2.381	50	80	12	80	65	62	9	M6	1x4	1296	4838	71
DFU03206-4		6	3.969	50	80	12	105	65	62	9	M6	1x4	2632	7979	78
DFU03208-4		8	4.762	50	80	12	122	65	62	9	M6	1x4	3387	9622	82
DFU04006-4	40	6	3.969	63	93	14	108	78	70	9	M6	1x4	2873	9913	91
DFU04008-4		8	4.762	63	93	14	132	78	70	9	M6	1x4	3712	11947	96
DFU05020-4	50	20	7.144	75	110	16	280	93	85	11	M8	1x4	7142	22588	126
DFU06320-4	63	20	9.525	95	135	20	290	115	100	13.5	M8	1x4	11444	36653	152
DFU08020-4	80	20	9.525	125	165	25	295	145	130	13.5	M8	1x4	12911	47747	187
DFU10020-4	100	20	9.525	150	202	30	340	170	155	17.5	M8	1x4	14303	60698	222

TBI MOTION BALL SCREW

2-2 Precision Ground Ball Screw Series

SFNI/SFI Series Specifications

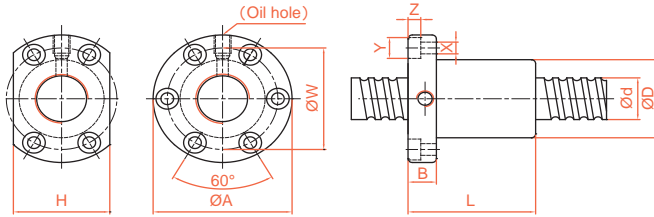

Unit : mm

Model No.	d	I	Da	Dimension											Load Rating		K kgf/μm
				D	A	B	L	W	H	X	Y	Z	Q	n	Ca (kgf)	Coa (kgf)	
SFNI01605-4*	16	5	3.175	30	49	10	45	39	34	4.5	8	4.5	M6	1x4	1380	3052	33
SFNI01610-3*		10	3.175	34	58	10	57	45	34	5.5	9.5	5.5	M6	1x3	1103	2401	27
SFNI02005-4*	20	5	3.175	34	57	11	51	45	40	5.5	9.5	5.5	M6	1x4	1551	3875	39
SFNI02505-4*		5	3.175	40	63	11	51	51	46	5.5	9.5	5.5	M8	1x4	1724	4904	45
SFNI02510-4*	25	10	4.762	46	72	12	80	58	52	6.5	11	6.5	M6	1x4	2954	7295	51
SFNI03205-4*		5	3.175	46	72	12	52	58	52	6.5	11	6.5	M8	1x4	1922	6343	52
SFNI03210-4*	32	10	6.35	54	88	15	85	70	62	9	14	8.5	M8	1x4	4805	12208	62
SFNI04005-4*		5	3.175	56	90	15	55	72	64	9	14	8.5	M8	1x4	2110	7988	59
SFNI04010-4*	40	10	6.35	62	104	18	88	82	70	11	17.5	11	M8	1x4	5399	15500	72
SFNI05010-4*		50	10	6.35	72	114	18	88	92	82	11	17.5	11	M8	1x4	6004	19614
SFNI06310-4*	63	10	6.35	85	131	22	93	107	95	14	20	13	M8	1x4	6719	25358	95
SFNI08010-4		80	10	6.35	105	150	22	93	127	115	14	20	13	M8	1x4	7346	31953
SFI01604-4	16	4	2.381	30	49	10	45	39	34	4.5	8	4.5	M6	1x4	973	2406	32
SFI02004-4		4	2.381	34	57	11	46	45	40	5.5	9.5	5.5	M6	1x4	1066	2987	37
SFI0205T-4	20	5.08	3.175	34	57	11	51	45	40	5.5	9.5	5.5	M6	1x4	1550	3875	39
SFI02504-4*		4	2.381	40	63	11	46	51	46	5.5	9.5	5.5	M6	1x4	1180	3795	43
SFI0255T-4	25	5.08	3.175	40	63	11	51	51	46	5.5	9.5	5.5	M8	1x4	1724	4903	45
SFI03204-4		32	4	2.381	46	72	12	47	58	52	6.5	11	6.5	M6	1x4	1296	4838

SFM Series Specifications

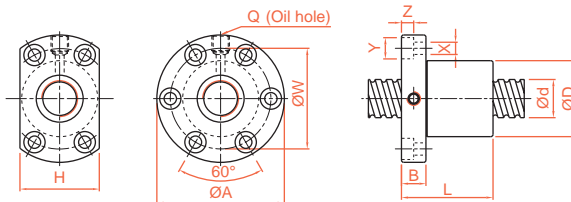

Unit : mm

Model No.	d	I	Da	Dimension											Load Rating		K kgf/μm
				D	A	B	L	W	H	X	Y	Z	Q	n	Ca (kgf)	Coa (kgf)	
SFM03205-4*	32	5	3.175	48	74	12	52	60	60	6.5	11	6.5	M8	1x4	1922	6343	53
SFM0325T-4*		5.08	3.175	48	74	12	53	60	60	6.5	11	6.5	M8	1x4	1922	6343	53

* Left helix available

OFI/DFI Series Specifications

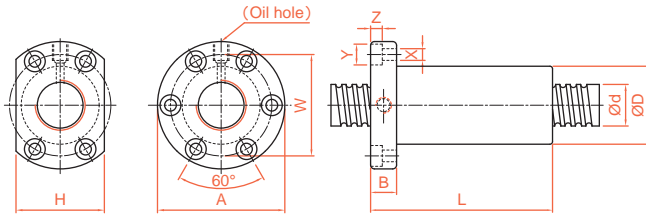

Unit : mm

ModelNo.	d	I	Da	Dimension											LoadRating		K kgf/μm
				D	A	B	L	W	H	X	Y	Z	Q	n	Ca (kgf)	Coa (kgf)	
OFI01605-4	16	5	3.175	30	49	10	75	39	34	4.5	8	4.5	M6	1x8	1380	3052	44
OFI02005-4	20	5	3.175	34	57	11	85	45	40	5.5	9.5	5.5	M6	1x8	1551	3875	52
OFI02505-4	25	5	3.175	40	63	11	86	51	46	5.5	9.5	5.5	M8	1x8	1724	4904	62
OFI02510-4		10	4.762	46	72	12	130	58	52	6.5	11	6.5	M6	1x8	2954	7295	68
OFI03205-4	32	5	3.175	46	72	12	87	58	52	6.5	11	6.5	M8	1x8	1922	6343	72
OFI03210-4		10	6.35	54	88	15	145	70	62	9	14	8.5	M8	1x8	4805	12208	83
OFI04005-4	40	5	3.175	56	90	15	90	72	64	9	14	8.5	M8	1x8	2110	7988	84
OFI04010-4		10	6.35	62	104	18	148	82	70	11	17.5	11	M8	1x8	5399	15500	99
OFI05010-4	50	10	6.35	72	114	18	148	92	82	11	17.5	11	M8	1x8	6004	19614	115
OFI06310-4	63	10	6.35	85	131	22	153	107	95	14	20	13	M8	1x8	6719	25358	135
OFI08010-4	80	10	6.35	105	150	22	153	127	115	14	20	13	M8	1x8	7346	31953	156
DFI01604-4	16	4	2.381	30	49	10	80	39	34	4.5	8	4.5	M6	1x4	973	2406	44
DFI02004-4	20	4	2.381	34	57	11	80	45	40	5.5	9.5	5.5	M6	1x4	1066	2987	51
DFI02504-4	25	4	2.381	40	63	11	80	51	46	5.5	9.5	5.5	M6	1x4	1180	3795	60
DFI0255T-4		5.08	3.175	40	63	11	101	51	46	5.5	9.5	5.5	M8	1x4	1724	4903	62
DFI03204-4	32	4	2.381	46	72	12	80	58	52	6.5	11	6.5	M6	1x4	1296	4838	69
DFI0325T-4		5.08	3.175	46	72	12	102	58	52	6.5	11	6.5	M8	1x4	1922	6343	72

DFM Series Specifications

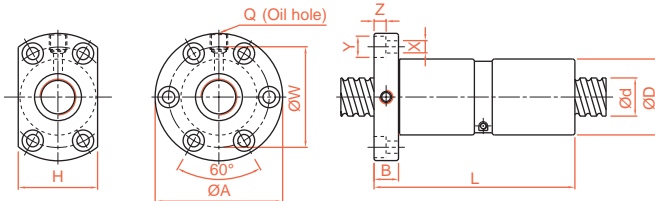

Unit : mm

Model No.	d	I	Da	Dimension											Load Rating		K kgf/μm
				D	A	B	L	W	H	X	Y	Z	Q	n	Ca (kgf)	Coa (kgf)	
DFM03205-4*	32	5	3.175	48	74	12	102	60	60	6.5	11	6.5	M8	1x4	1922	6343	73
DFM0325T-4*		5.08	3.175	48	74	12	104	60	60	6.5	11	6.5	M8	1x4	1922	6343	73

Note : For double ball screw nut order, please contact **TBI MOTION** in advance. ※ ☆ Left helix available

TBI MOTION BALL SCREW

2-2 Precision Ground Ball Screw Series

SFV Series Specifications

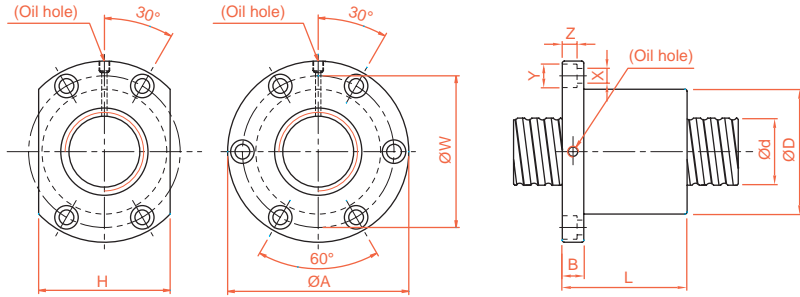

Unit : mm

Model No.	d	I	Da	Dimension											Load Rating		K kgf/µm
				D	A	B	L	W	H	X	Y	Z	Q	n	Ca (kgf)	Coa (kgf)	
SFV01205-2.8	12	5	2.5	30	50	10	42	40	32	4.5	8	4.5	M6	2.8x1	661	1316	19
SFV01210-2.7		10	2.5	30	50	10	53	40	32	4.5	8	4.5	M6	2.7x1	623	1241	18
SFV01510-2.7	15	10	3.175	34	58	10	57	45	34	5.5	9.5	5.5	M6	2.7x1	972	2020	23
SFV01604-3.8	16	4	2.381	34	57	11	45	45	34	5.5	9.5	5.5	M6	3.8x1	931	2285	31
SFV01605-4.8		5	3.175	40	63	11	58	51	42	5.5	9.5	5.5	M6	4.8x1	1614	3662	40
SFV01610-2.7	20	10	3.175	40	63	11	56	51	42	5.5	9.5	5.5	M6	2.7x1	1008	2161	24
SFV02004-4.8		4	2.381	40	60	10	50	50	40	4.5	8	4	M6	4.8x1	1247	3584	45
SFV02005-4.8	20	5	3.175	44	67	11	57	55	52	5.5	9.5	5.5	M6	4.8x1	1814	4650	47
SFV02010-2.7		10	3.969	46	74	13	57	59	46	6.6	11	6.5	M6	2.7x1	1518	3398	30
SFV02020-1.8	25	20	3.175	46	74	13	70	59	46	6.6	11	6.5	M6	1.8x1	764	1758	19
SFV02050-4.8		5	3.175	50	73	11	55	61	52	5.5	9.5	5.5	M6	4.8x1	2017	5884	56
SFV02506-4.8	25	6	3.969	53	76	11	62	64	58	5.5	9.5	5.5	M6	4.8x1	2711	7268	58
SFV02508-4.8		8	4.762	56	85	13	70	71	64	6.5	11	6.5	M6	4.8x1	3466	8776	61
SFV02510-2.7	32	10	6.35	68	102	15	70	84	82	9	14	8.5	M8	2.7x1	3040	6547	37
SFV02525-1.8		25	3.175	50	73	13	83	61	52	5.5	9.5	5.5	M8	1.8x1	843	2199	22
SFV03204-4.8	32	4	2.381	54	81	12	50	67	64	6.6	11	6.5	M6	4.8x1	1517	5806	62
SFV03205-4.8		5	3.175	58	85	12	56	71	64	6.6	11	6.5	M8	4.8x1	2249	7612	66
SFV03206-4.8	32	6	3.969	62	89	12	60	75	68	6.6	11	6.5	M8	4.8x1	3079	9575	70
SFV03208-4.8		8	4.762	66	100	15	75	82	76	9	14	8.5	M8	4.8x1	3962	11547	74
SFV03210-4.8	40	10	6.35	74	108	15	96	90	82	9	14	9	M8	4.8x1	5620	14649	76
SFV03220-2.7		20	6.35	74	108	16	100	90	82	9	14	8.5	M8	2.7x1	3509	8644	46
SFV04005-4.8	40	5	3.175	67	101	15	59	83	72	9	14	8.5	M8	4.8x1	2468	9586	76
SFV04010-4.8		10	6.35	82	124	18	100	102	94	11	17.5	11	M8	4.8x1	6316	18600	90
SFV04020-2.7	50	20	6.35	82	124	18	100	102	90	11	17.5	11	M8	2.7x1	3935	10893	56
SFV05005-4.8		5	3.175	80	114	15	60	96	82	9	14	8.5	M8	4.8x1	2698	12053	87
SFV05010-4.8	50	10	6.35	93	135	16	93	113	98	11	17.5	11	M8	4.8x1	7023	23537	106
SFV05020-2.7		20	9.525	105	152	28	121	128	110	14	20	13	M8	2.7x1	7336	19700	68
SFV06310-4.8	63	10	6.35	108	154	22	105	130	110	14	20	13	M8	4.8x1	7860	30430	126
SFV06320-2.7		20	9.525	122	180	28	120	150	130	18	26	17.5	M8	2.7x1	8162	24741	80
SFV08010-4.8	80	10	6.35	130	176	22	105	152	132	14	20	13	M8	4.8x1	8593	38344	145
SFV08020-4.8		20	9.525	143	204	28	180	172	148	18	26	18	M8	4.8x1	15103	57296	168
SFV08020-7.6	20	9.525	143	204	28	240	172	148	18	26	18	M8	3.8x2	22423	90719	260	

OFV/DFV Series Specifications

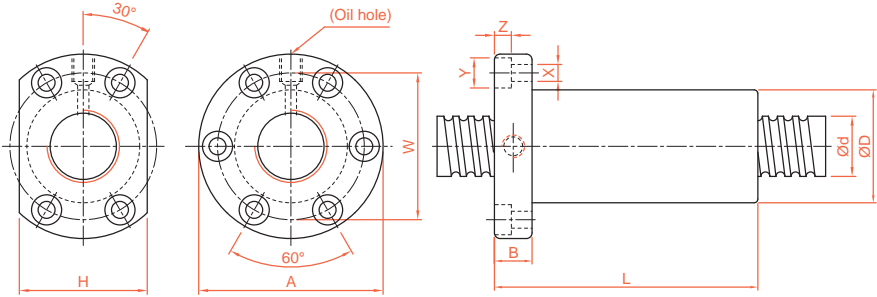

Unit : mm

Model No.	d	I	Da	Dimension										Load Rating		K kgf/μm	
				D	A	B	L	W	H	X	Y	Z	Q	n	Ca (kgf)		Coa (kgf)
OFV01605-4.8	16	5	3.175	40	63	11	100	51	42	5.5	9.5	5.5	M6	4.8x2	1614	3662	53
OFV02005-4.8	20	5	3.175	44	67	11	102.5	55	52	5.5	9.5	5.5	M6	4.8x2	1814	4650	63
OFV02505-4.8	25	5	3.175	50	73	11	96	61	52	5.5	9.5	5.5	M8	4.8x2	2017	5884	75
OFV03205-4.8	32	5	3.175	58	85	12	98	71	64	6.6	11	6.5	M8	4.8x2	2249	7612	90
OFV03210-4.8		10	6.35	74	108	15	166	90	82	9	14	9	M8	4.8x2	5620	14649	101
OFV04005-4.8	40	5	3.175	67	101	15	100	83	72	9	14	8.5	M8	4.8x2	2468	9586	105
OFV04010-4.8		10	6.35	82	124	18	174	102	94	11	17.5	11	M8	4.8x2	6316	18600	121
OFV05010-4.8	50	10	6.35	93	135	16	167	113	98	11	17.5	11	M8	4.8x2	7023	23537	144
OFV06310-4.8	63	10	6.35	108	154	22	177	130	110	14	20	13	M8	4.8x2	7860	30430	172
OFV08010-4.8	80	10	6.35	130	176	22	178	152	132	14	20	13	M8	4.8x2	8593	38344	201
DFV01510-2.7	15	10	3.175	34	58	10	107	45	34	5.5	9.5	5.5	M6	2.7x1	972	2020	30
DFV01604-3.8	16	4	2.381	34	57	11	89	45	34	5.5	9.5	5.5	M6	3.8x1	931	2285	42
DFV02004-4.8	20	4	2.381	40	60	10	94	50	40	4.5	8	4	M6	4.8x1	1247	3584	61
DFV02010-2.7		10	3.969	46	74	13	117	59	46	6.6	11	6.5	M6	2.7x1	1518	3398	40
DFV02506-4.8	25	6	3.969	53	76	11	116	64	58	5.5	9.5	5.5	M6	4.8x1	2711	7268	78
DFV02508-4.8		8	4.762	56	85	13	134	71	64	6.5	11	6.5	M6	4.8x1	3466	8776	82
DFV02510-2.7	10	6.35	68	102	15	130	84	82	9	14	8.5	M8	2.7x1	3040	6547	49	
DFV03204-4.8	32	4	2.381	54	81	12	94	67	64	6.6	11	6.5	M6	4.8x1	1517	5806	85
DFV03206-4.8		6	3.969	62	89	12	114	75	68	6.6	11	6.5	M8	4.8x1	3079	9575	95
DFV03208-4.8		8	4.762	66	100	15	139	82	76	9	14	8.5	M8	4.8x1	3962	11547	100
DFV03220-2.7	20	6.35	74	108	16	200	90	82	9	14	8.5	M8	2.7x1	3509	8644	61	
DFV04020-2.7	40	20	6.35	82	124	18	200	102	90	11	17.5	11	M8	2.7x1	3935	10893	74
DFV05005-4.8	50	5	3.175	80	114	15	115	96	82	9	14	8.5	M8	4.8x1	2698	12053	122
DFV05020-2.7		20	9.525	105	152	28	221	128	110	14	20	13	M8	2.7x1	7336	19700	90
DFV06320-2.7	63	20	9.525	122	180	28	220	150	130	18	26	17.5	M8	2.7x1	8162	24741	107
DFV08020-4.8	80	20	9.525	143	204	28	340	172	148	18	26	18	M8	4.8x1	15103	57296	226
DFV08020-7.6		20	9.525	143	204	28	460	172	148	18	26	18	M8	3.8x2	22423	90719	351

Note : For double ball screw nut order, please contact **TBI MOTION** in advance.

TBI MOTION BALL SCREW

2-2 Precision Ground Ball Screw Series

SFY Series Specifications

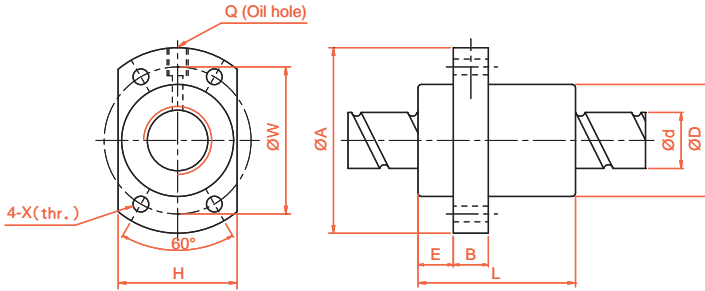

Unit : mm

Large Lead Model No.	d	I	Da	Dimension										Load Rating		K kgf/μm
				D	A	E	B	L	W	H	X	Q	n	Ca (kgf)	Coa (kgf)	
SFY01616-3.6	16	16	2.778	32	53	10.1	10	45	42	34	4.5	M6	1.8x2	1073	2551	31
SFY01616-5.6		16	2.778	32	53	10.1	10	61	42	34	4.5	M6	2.8x2	1568	3968	47
SFY02020-3.6	20	20	3.175	39	62	13	10	52	50	41	5.5	M6	1.8x2	1387	3515	37
SFY02020-5.6		20	3.175	39	62	13	10	72	50	41	5.5	M6	2.8x2	2029	5468	56
SFY02525-3.6	25	25	3.969	47	74	15	12	64	60	49	6.6	M6	1.8x2	2074	5494	45
SFY02525-5.6		25	3.969	47	74	15	12	89	60	49	6.6	M6	2.8x2	3032	8546	69
SFY03232-3.6	32	32	4.762	58	92	17	12	78	74	60	9	M6	1.8x2	3021	8690	58
SFY03232-5.6		32	4.762	58	92	17	12	110	74	60	9	M6	2.8x2	4417	13517	88
SFY04040-3.6	40	40	6.35	73	114	19.5	15	99	93	75	11	M6	1.8x2	4831	14062	70
SFY04040-5.6		40	6.35	73	114	19.5	15	139	93	75	11	M6	2.8x2	7065	21874	106
SFY05050-3.6	50	50	7.938	90	135	21.5	20	117	112	92	14	M6	1.8x2	7220	21974	86
SFY05050-5.6		50	7.938	90	135	21.5	20	167	112	92	14	M6	2.8x2	10558	34182	131
Twin Lead Model No.	d	I	Da	Dimension										Ca (kgf)	Coa (kgf)	K kgf/μm
SFY01632-1.6	16	32	2.778	32	53	10.1	10	42.5	42	34	4.5	M6	0.8x2	493	1116	11
SFY01632-3.6		32	2.778	32	53	10.1	10	74.5	42	34	4.5	M6	1.8x2	989	2511	23
SFY02040-1.6	20	40	3.175	39	62	13	10	48	50	41	5.5	M6	0.8x2	653	1597	15
SFY02040-3.6		40	3.175	39	62	13	10	88	50	41	5.5	M6	1.8x2	1311	3592	30
SFY02550-1.6	25	50	3.969	47	74	15	12	58	60	49	6.6	M6	0.8x2	976	2495	19
SFY02550-3.6		50	3.969	47	74	15	12	108	60	49	6.6	M6	1.8x2	1960	5614	32
SFY03264-1.6	32	64	4.762	58	92	17	12	71	74	60	9	M6	0.8x2	1374	3571	22
SFY03264-3.6		64	4.762	58	92	17	12	135	74	60	9	M6	1.8x2	2759	8441	46
SFY04080-1.6	40	80	6.35	73	114	19.5	15	90	93	75	11	M6	0.8x2	2273	6387	29
SFY04080-3.6		80	6.35	73	114	19.5	15	170	93	75	11	M6	1.8x2	4566	14370	50
SFY050100-1.6	50	100	7.938	90	135	21.5	20	111	112	92	14	M6	0.8x2	3398	9980	35
SFY050100-3.6		100	7.938	90	135	21.5	20	211	112	92	14	M6	1.8x2	6824	22455	72

DFS (DIN 69051 FORM B) Series Specifications

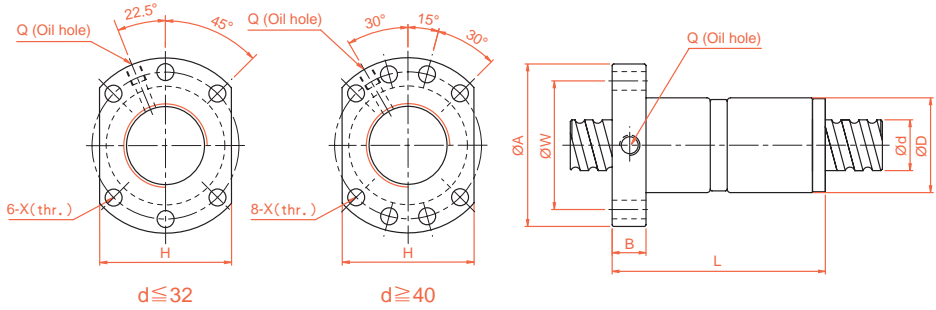

Unit : mm

Model No.	d	I	Da	Dimension								Load Rating		K kgf/μm	
				D	A	B	L	W	H	X	Q	n	Ca (kgf)		Coa (kgf)
DFS01605-3.8	15	5	2.778	28	48	10	73	38	40	5.5	M6	3.8x1	1112	2507	41
DFS01610-2.8		10	2.778	28	48	10	97	38	40	5.5	M6	2.8x1	839	1821	31
DFS02005-3.8	20	5	3.175	36	58	10	75	47	44	6.6	M6	3.8x1	1484	3681	50
DFS02010-3.8		10	3.175	36	58	10	120	47	44	6.6	M6	3.8x1	1516	3833	53
DFS02505-3.8	25	5	3.175	40	62	10	75	51	48	6.6	M6	3.8x1	1650	4658	59
DFS02510-3.8		10	3.175	40	62	12	122	51	48	6.6	M6	3.8x1	1638	4633	61
DFS03205-3.8	31	32	3.175	50	80	12	82	65	62	9	M6	3.8x1	1839	6026	71
DFS03210-3.8		10	3.969	50	80	13	122	65	62	9	M6	3.8x1	2460	7255	75
DFS03220-2.8	20	3.969	50	80	12	160	65	62	9	M6	2.8x1	1907	5482	58	
DFS04005-3.8	38	40	3.175	63	93	15	85	78	70	9	M8	3.8x1	2018	7589	83
DFS04010-3.8		10	6.35	63	93	14	123	78	70	9	M8	3.8x1	5035	13943	91
DFS04020-2.8	20	6.35	63	93	14	162	78	70	9	M8	2.8x1	3959	10715	73	
DFS05005-3.8	48	50	3.175	75	110	15	85	93	85	11	M8	3.8x1	2207	9542	96
DFS05010-3.8		10	6.35	75	110	18	138	93	85	11	M8	3.8x1	5638	17852	109
DFS05020-3.8	20	6.35	75	110	18	218	93	85	11	M8	3.8x1	5749	18485	116	

Note : For double ball screw nut order, please contact **TBI MOTION** in advance.

TBI MOTION BALL SCREW

2-2 Precision Ground Ball Screw Series

SCNI/SCI Series Specifications

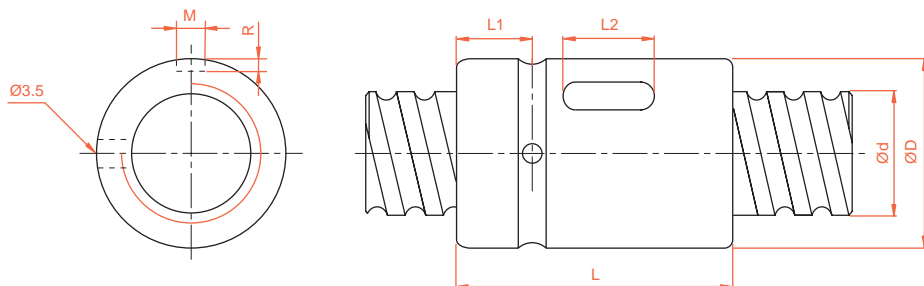

Unit : mm

Model No.	d	I	Da	Dimension							Load Rating		K kgf/μm
				D	L	L1	L2	M	R	n	Ca (kgf)	Coa (kgf)	
SCNI 01605-4	16	5	3.175	30	45	9	20	5	3	1x4	1380	3052	33
SCNI 02005-4	20	5	3.175	34	45	9	20	5	3	1x4	1551	3875	39
SCNI 02505-4	25	5	3.175	40	45	9	20	5	3	1x4	1724	4904	45
SCNI 02510-4		10	4.762	46	85	13	30	5	3	1x4	2954	7295	51
SCNI 03205-4	32	5	3.175	46	45	9	20	5	3	1x4	1922	6343	52
SCNI 03210-4		10	6.35	54	85	13	30	5	3	1x4	4805	12208	62
SCNI 04005-4	40	5	3.175	56	45	9	20	5	3	1x4	2110	7988	59
SCNI 04010-4		10	6.35	62	85	13	30	5	3	1x4	5399	15500	72
SCNI 05010-4	50	10	6.35	72	85	13	30	5	3	1x4	6004	19614	83
SCNI 06310-4	63	10	6.35	85	85	13	30	6	3.5	1x4	6719	25358	95
SCNI 08010-4	80	10	6.35	105	85	13	30	8	4.5	1x4	7346	31953	109
SCI 01604-4	16	4	2.381	30	40	9	15	3	1.5	1x4	973	2406	32
SCI 02004-4	20	4	2.381	34	40	9	15	3	1.5	1x4	1066	2987	37
SCI 02504-4	25	4	2.381	40	40	9	15	3	1.5	1x4	1180	3795	43
SCI 03204-4	32	4	2.381	46	40	9	15	3	1.5	1x4	1296	4838	49

SFK Series Specifications

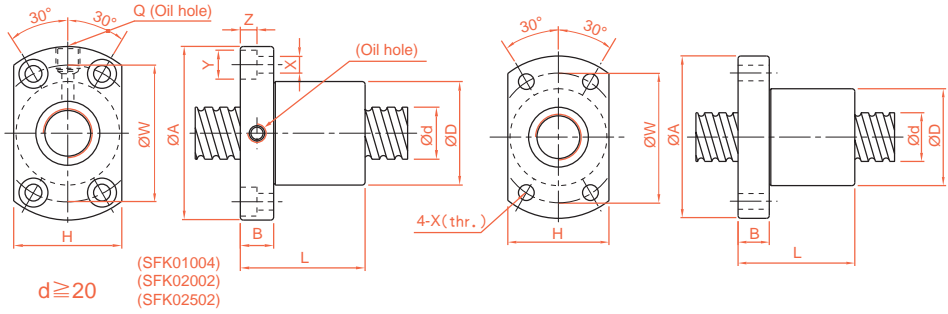

Unit : mm

Model No.	d	I	Da	Dimension											Ca (kgf)	Coa (kgf)	K (kgf/μm)
				D	A	B	L	W	H	X	Y	Z	Q	n			
SFK00401	4	1	0.8	10	20	3	12	15	14	2.9	-	-	-	1x2	64	97	5
SFK00601	6	1	0.8	12	24	3.5	15	18	16	3.4	-	-	-	1x3	111	224	9
SFK00801*	8	1	0.8	14	27	4	16	21	18	3.4	-	-	-	1x4	161	403	14
SFK00802*		2	1.2	14	27	4	16	21	18	3.4	-	-	-	1x3	222	458	13
SFK0082.5		2.5	1.2	16	29	4	26	23	20	3.4	-	-	-	1x3	221	457	13
SFK01002*	10	2	1.2	18	35	5	28	27	22	4.5	-	-	-	1x3	243	569	15
SFK01004		4	2	26	46	10	34	36	28	4.5	8	4.5	M6	1x3	468	905	17
SFK01202*	12	2	1.2	20	37	5	28	29	24	4.5	-	-	-	1x4	334	906	22
SFK01402*	14	2	1.2	21	40	6	23	31	26	5.5	-	-	-	1x4	354	1053	24
SFK01602*	16	2	1.2	25	43	10	40	35	29	5.5	-	-	M6	1x4	373	1200	26
SFK02002	20	2	1.2	50	80	15	55	65	68	6.5	10.5	6	M6	1x6	581	2284	48
SFK02502	25	2	1.2	50	80	13	43	65	68	6.5	10.5	6	M6	1x5	540	2381	46

※ * Left helix available

Unit : mm

Model No.	d	I	Da	Dimension											Ca (kgf)	Coa (kgf)	K (kgf/μm)
				D	A	B	L	W	H	X	Y	Z	Q	n			
XSUR01204T3D-02	12	4	2.5	24	40	6	28	32	25	3.5	-	-	-	1x3	704	1413	-
XSUR01205T3D-00		5	2.5	22	37	8	39	29	24	4.5	-	-	-	1x3	702	1409	17

TBI MOTION BALL SCREW

2-2 Precision Ground Ball Screw Series

BSH Series Specifications

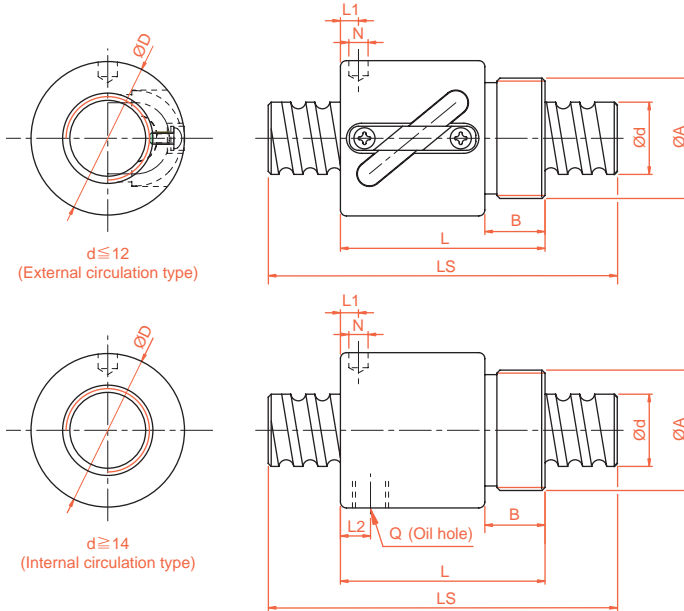

Unit : mm

Model No.	d	I	Da	Dimension									Ca (kgf)	Coa (kgf)	K kgf/ μ m
				D	A	B	L	L1	N	L2	Q	n			
BSHR0082.5-2.5	8	2.5	1.2	17.5	M15x1P	7.5	23.5	10	3	-	-	2.5x1	189	381	11
BSHR01002-3.5	10	2	1.2	19.5	M17x1P	7.5	22	3	3.2	-	-	3.5x1	277	664	17
BSHR01004-2.5		4	2	25	M20x1P	10	34	3	3	-	-	2.5x1	400	754	14
BSHR01204-3.5	12	4	2.5	25.5	M20x1P	10	34	13	3	-	-	3.5x1	804	1649	23
BSHR01205-3.5		5	2.5	25.5	M20x1P	10	39	16.25	3	-	-	3.5x1	801	1644	24
BSHR01404-3	14	4	2.5	32.1	M25x1.5P	10	35	11	3	-	-	1x3	748	1609	26
BSHR01604-3	16	4	2.381	29	M22x1.5P	8	32	4	3.2	-	-	1x3	759	1804	24
BSHR01605-3		5	3.175	32.5	M26x1.5P	12	42	19.25	3	-	-	1x3	1077	2289	25
BSHR01610-2		10	3.175	32	M26x1.5P	12	50	3	4	3	M4	1x2	779	1601	14
BSHR02005-3	20	5	3.175	38	M35x1.5P	15	45	20.3	3	-	-	1x3	1211	2906	30
BSHR02505-4	25	5	3.175	43	M40x1.5P	19	69	32.11	3	8	M6	1x4	1724	4904	37
BSHR02510-4		10	4.762	43	M40x1.5P	19	84	8	6	8	M6	1x4	2954	7295	41

※ Standard ball nut from $\phi 8$ ~ $\phi 16$ is assembled without wiper.

XSVR01210-01 Series Specifications (Finish Shaft Ends)

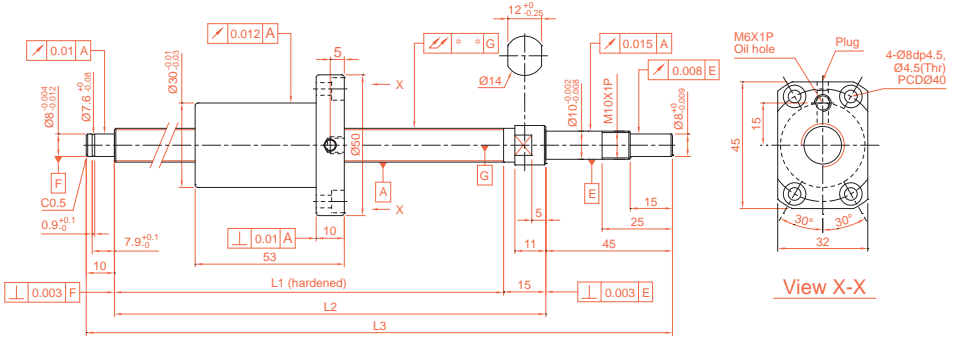

BCD	12.85
Ball Dia (mm)	2.5
Lead (mm)	10
No. of Turns	2.7x1
Lead Angle	13.91°
Threading Direction	R
Spring Force (kg)	0.1~0.2
Preload (kgf)	25
Dynamic Load Rating Ca (kgf)	411
Static Load Rating Coa (kgf)	638
Accuracy Grade	0.018

Unit : mm

Travel Length (mm)	Model No.	Shaft Length (mm)			Slant of Axle Center ∠
		L1	L2	L3	
100	XSVR01210B1DGC5-230-P1	160	175	230	0.035
150	XSVR01210B1DGC5-280-P1	210	225	280	0.035
250	XSVR01210B1DGC5-380-P1	310	325	380	0.050
350	XSVR01210B1DGC5-480-P1	410	425	480	0.060
450	XSVR01210B1DGC5-580-P1	510	525	580	0.075

TBI MOTION BALL SCREW

2-2 Precision Ground Ball Screw Series

XSVR01510-00 Series Specifications (Finish Shaft Ends)

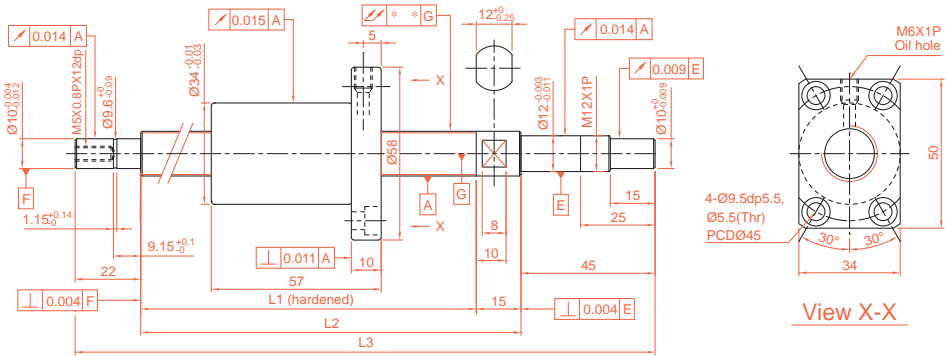

BCD	15.5
Ball Dia (mm)	3.175
Lead (mm)	10
No. of Turns	2.7x1
Lead Angle	11.6°
Threading Direction	R
Spring Force (kg)	0.1~0.3
Preload (kgf)	38
Dynamic Load Rating Ca (kgf)	611
Static Load Rating Coa (kgf)	950
Accuracy Grade	0.018

Unit : mm

Travel Length (mm)	Model No.	Shaft Length (mm)			Slant of Axle Center
		L1	L2	L3	∕∕
100	XSVR01510B1DGC5-271-P1	189	204	271	0.025
150	XSVR01510B1DGC5-321-P1	239	254	321	0.035
200	XSVR01510B1DGC5-371-P1	289	304	371	0.035
250	XSVR01510B1DGC5-421-P1	339	354	421	0.040
300	XSVR01510B1DGC5-471-P1	389	404	471	0.040
350	XSVR01510B1DGC5-521-P1	439	454	521	0.050
400	XSVR01510B1DGC5-571-P1	489	504	571	0.050
450	XSVR01510B1DGC5-621-P1	539	554	621	0.050
500	XSVR01510B1DGC5-671-P1	589	604	671	0.065
550	XSVR01510B1DGC5-721-P1	639	654	721	0.065
600	XSVR01510B1DGC5-771-P1	689	704	771	0.065
700	XSVR01510B1DGC5-871-P1	789	804	871	0.085
800	XSVR01510B1DGC5-971-P1	889	904	971	0.085

XSVR01520-01 Series Specifications (Finish Shaft Ends)

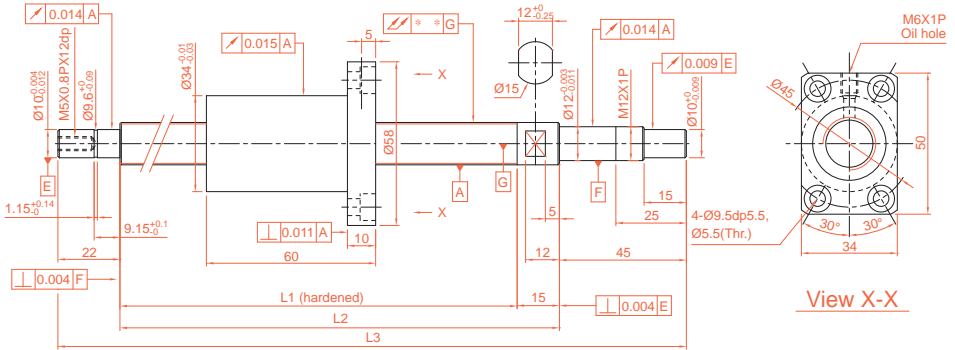

BCD	15.5
Ball Dia (mm)	3.175
Lead (mm)	20
No. of Turns	1.8x1
Lead Angle	22.33°
Threading Direction	R
Spring Force (kg)	0.1~0.3
Preload (kgf)	38
Dynamic Load Rating Ca (kgf)	580
Static Load Rating Coa (kgf)	875
Accuracy Grade	0.018

Unit : mm

Travel Length (mm)	Model No.	Shaft Length (mm)			Slant of Axle Center
		L1	L2	L3	∕
100	XSVR01520A1DGC5-271-P1	189	204	271	0.025
150	XSVR01520A1DGC5-321-P1	239	254	321	0.035
200	XSVR01520A1DGC5-371-P1	289	304	371	0.035
250	XSVR01520A1DGC5-421-P1	339	354	421	0.040
300	XSVR01520A1DGC5-471-P1	389	404	471	0.040
350	XSVR01520A1DGC5-521-P1	439	454	521	0.050
400	XSVR01520A1DGC5-571-P1	489	504	571	0.050
450	XSVR01520A1DGC5-621-P1	539	554	621	0.050
500	XSVR01520A1DGC5-671-P1	589	604	671	0.065
550	XSVR01520A1DGC5-721-P1	639	654	721	0.065
600	XSVR01520A1DGC5-771-P1	689	704	771	0.065
700	XSVR01520A1DGC5-871-P1	789	804	871	0.085
800	XSVR01520A1DGC5-971-P1	889	904	971	0.085

TBI MOTION BALL SCREW

2-2 Precision Ground Ball Screw Series

XSVR02010-00 Series Specifications (Finish Shaft Ends)

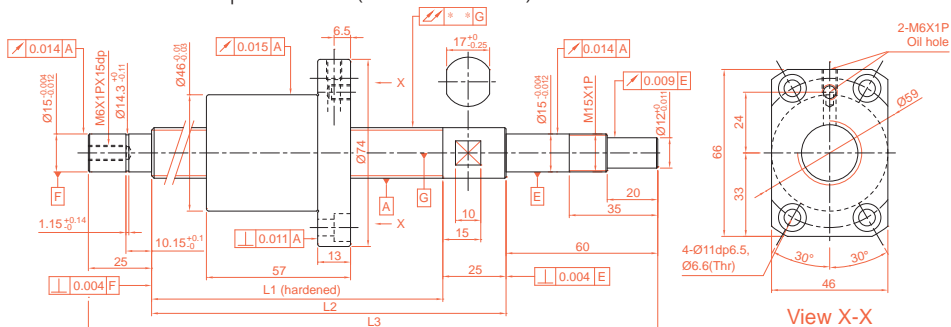

BCD	21.35
Ball Dia (mm)	3.969
Lead (mm)	10
No. of Turns	2.7x1
Lead Angle	8.48°
Threading Direction	R
Spring Force (kg)	0.1~0.3
Preload (kgf)	43
Dynamic Load Rating Ca (kgf)	977
Static Load Rating Coa (kgf)	1732
Accuracy Grade	0.018

Unit : mm

Travel Length (mm)	Model No.	Shaft Length (mm)			Slant of Axle Center
		L1	L2	L3	∠
200	XSVR02010B1DGC5-399-P1	289	314	399	0.035
300	XSVR02010B1DGC5-499-P1	389	414	499	0.040
400	XSVR02010B1DGC5-599-P1	489	514	599	0.050
500	XSVR02010B1DGC5-699-P1	589	614	699	0.065
600	XSVR02010B1DGC5-799-P1	689	714	799	0.065
700	XSVR02010B1DGC5-899-P1	789	814	899	0.085
800	XSVR02010B1DGC5-999-P1	889	914	999	0.085
900	XSVR02010B1DGC5-1099-P1	989	1014	1099	0.110
1000	XSVR02010B1DGC5-1199-P1	1089	1114	1199	0.110

XSVR02020-00 Series Specifications (Finish Shaft Ends)

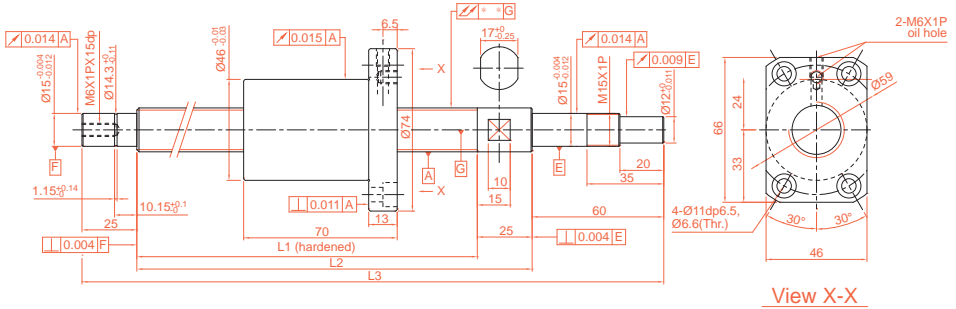

BCD	20.75
Ball Dia (mm)	3.175
Lead (mm)	20
No. of Turns	1.8x1
Lead Angle	17.05°
Threading Direction	R
Spring Force (kg)	0.1~0.3
Preload (kgf)	31
Dynamic Load Rating Ca (kgf)	649
Static Load Rating Coa (kgf)	1134
Accuracy Grade	0.018

Unit : mm

Travel Length (mm)	Model No.	Shaft Length (mm)			Slant of Axle Center
		L1	L2	L3	∕∕
200	XSVR02020A1DGC5-399-P1	289	314	399	0.035
300	XSVR02020A1DGC5-499-P1	389	414	499	0.040
400	XSVR02020A1DGC5-599-P1	489	514	599	0.050
500	XSVR02020A1DGC5-699-P1	589	614	699	0.065
600	XSVR02020A1DGC5-799-P1	689	714	799	0.065
700	XSVR02020A1DGC5-899-P1	789	814	899	0.085
800	XSVR02020A1DGC5-999-P1	889	914	999	0.085
900	XSVR02020A1DGC5-1099-P1	989	1014	1099	0.110
1000	XSVR02020A1DGC5-1199-P1	1089	1114	1199	0.110

TBI MOTION BALL SCREW

2-3 Rolled Ball Screw

■ 2-3-1 Rolled Screws

Rolled screws are made through thread roller. Generally rolled screw has a smoother operation while lowering friction and backlash. Therefore, it gradually replaced the traditional ACME screws and trapezoidal screws. Moreover, rolled screws can eliminate axial play by preloading nut with a cost effective pricing compare to ground screw.

■ 2-3-2 The Features of TBI MOTION Rolled Ball Screw

(1) Lead Accuracy Up to Grade C5

C7 and C10 Screws have been Standardized. C5 on request.

(2) Precision Ground Ball Nut

High Precision Ball Nut are interchangeable between ground and rolled screws.

(3) Available to ship separately

Ball screw and ball nuts can be shipped separated ensure shortest delivery time. The ball nuts are standardized with P0 preloaded, preload value can be adjusted through reballing.

■ 2-3-3 Nominal Model Code of Rolled Ball Screws

Nominal Model Code of Shaft

SC R 025 05 F C7 - 1000 + N3

① ② ③ ④ ⑤ ⑥ ⑦ ⑧

①	④	⑦
Type of Screw Shaft	Lead	Overall Length of Shaft
SC : standard	Unit : mm	Unit : mm
SS : For H, NH type nut		
②	⑤	⑧
Threading Direction	Product Code	Shaft Surface Treatment
R : Right	F : Rolled	□ : Standard
L : Left		B1 : Black Oxidation
		N1 : Hard Chrome Plating
③	⑥	P : Phosphating
Nominal Diameter	Accuracy Grade	N3 : Nickel Plating
Unit : mm	C5, C7, C10	N4 : Raydent
		N5 : Chrome Plating

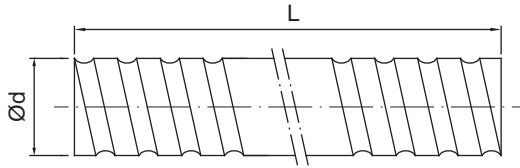

Fig 2.3.1 Screw Shaft Nominal Diameter

Table 2.3.1 Rolled Ball Screw Specifications $\varnothing 6\sim 32$

Unit : mm

Model No.	Accuracy Grade		Threading Direction		Number of Grooves	Standard Code of Shaft	Type of Nut	Overall Length of Shaft
			R : Right	L : Left				
d	I	Da						
6	1	0.8	C10, C7		R	SCR00601	K	1000
	1	0.8	C10, C7, C5		R	SCR00801	K	
8	2	1.2	C10, C7, C5		R	SCR00802	K	1000
	2.5	1.2	C10, C7, C5		R	SCR0082.5	K, BSH	
10	2	1.2	C10, C7, C5		R	SCR01002	K, BSH	3000
	4	2	C10, C7, C5		R	SCR01004	K, BSH	
12	2	1.2	C10, C7, C5		R	SCR01202	K	3000
	4	2.5	C10, C7, C5		R	SCR01204	U, BSH	
	5	2.5	C10, C7, C5		R	SCR01205-A	V, U, BSH, H	
	10	2.5	C10, C7, C5		R	SCR01210-B	V	
14	2	1.2	C10, C7, C5		R	SCR01402	K	1800
	4	2.5	C10, C7		R	SCR01404	BSH	3000
16	4	2.381	C10, C7, C5		R	SCR01604(N)	V, I, U, BSH	3000
	5	3.175	C10, C7, C5		R/L	SCR01605	V, NI, NU, BSH	
	10	3.175	C10, C7, C5		R	SCR01610	V, NI, NU, BSH	
	16	2.778	C10, C7, C5		R	SCR01616	Y	
20	32	2.778	C10, C7		R	SCR01632	Y	3000
	4	2.381	C10, C7, C5		R	SCR02004(N)	V, I, U	
	5	3.175	C10, C7, C5		R/L	SCR02005	V, NI, NU, BSH, H	
	20	3.175	C10, C7, C5		R	SCR02020	V, Y, H	
25	40	3.175	C10, C7		R	SCR02040	Y	6000
	4	2.381	C10, C7		R	SCR02504(N)	I, U	
	5	3.175	C10, C7, C5		R/L	SCR02505	V, NI, NU, BSH, H	
	10	4.762	C10, C7, C5		R	SCR02510-A	NI, NU, BSH	
	10	6.35	C10, C7, C5		R	SCR02510-B	V	
	25	3.969	C10, C7, C5		R	SCR02525	Y	
32	50	3.969	C10, C7		R	SCR02550	Y	6000
	4	2.381	C10, C7, C5		R	SCR03204(N)	V, I, U	
	5	3.175	C10, C7, C5		R/L	SCR03205	V, NI, NU, M, H	
	10	6.35	C10, C7, C5		R/L	SCR03210	V, NI, NU	
	32	4.762	C10, C7		R	SCR03232	Y	
64	4.762	C10, C7		R	SCR03264	Y		

TBI MOTION BALL SCREW

2-3 Rolled Ball Screw

Table 2.3.2 Standard Specifications Ø40~80

Unit : mm

Model No.			Accuracy Grade	Threading Direction	Number of Grooves	Standard Code of Shaft	Type of Nut	Overall Length of Shaft
d	I	Da		R : Right L : Left				
40	5	3.175	C10, C7, C5	R/L	1	SCR04005	V, NI, NU, H	6000
	10	6.35	C10, C7	R/L	1	SCR04010	V, NI, NU	
	20	6.35	C10, C7	R	2	SCR04020	V	
	40	6.35	C10, C7	R	4	SCR04040	Y	
	80	6.35	C10, C7	R	8	SCR04080	Y	
50	5	3.175	C10, C7, C5	R	1	SCR05005	V, H	6000
	10	6.35	C10, C7, C5	R/L	1	SCR05010	V, NI, NU	
	20	9.525	C10, C7	R	1	SCR05020	V	
	50	7.938	C10, C7	R	4	SCR05050	Y	
	100	7.938	C10, C7	R	8	SCR050100	Y	
63	10	6.35	C10, C7, C5	R	1	SCR06310	V, NI, NU	7000
	20	9.525	C10, C7	R	1	SCR06320	V, NU	
80	10	6.35	C10, C7, C5	R	1	SCR08010	V, NI, NU	7000
	20	9.525	C10, C7	R	1	SCR08020	V, NU	

Table 2.3.3 H-Type Specifications Ø16~50

Unit : mm

Model No.			Accuracy Grade	Threading Direction	Number of Grooves	Type-H Code of Shaft	Type of Nut	Overall Length of Shaft
d	I	Da		R : Right L : Left				
12	10	2.5	C10, C7, C5	R	2	SSR01210	H	3000
16	5	2.778	C10, C7, C5	R	1	SSR01605	H	3000
	10	2.778	C10, C7, C5	R	2	SSR01610	H	
	16	2.778	C10, C7, C5	R	4	SSR01616	H	
	20	2.778	C10, C7, C5	R	4	SSR01620	H	
20	10	3.175	C10, C7, C5	R	2	SSR02010	H	3000
25	10	3.175	C10, C7, C5	R	2	SSR02510	H	6000
	25	3.175	C10, C7	R	4	SSR02525	H	
32	10	3.969	C10, C7, C5	R	1	SSR03210	H	6000
	20	3.969	C10, C7	R	2	SSR03220	H	
	32	3.969	C10, C7	R	4	SSR03232	H	
40	10	6.35	C10, C7	R	1	SSR04010	H	6000
	20	6.35	C10, C7, C5	R	2	SSR04020	H	
	40	6.35	C10, C7	R	4	SSR04040	H	
50	10	6.35	C10, C7	R	1	SSR05010	H	6000
	20	6.35	C10, C7	R	2	SSR05020	H	
	50	6.35	C10, C7	R	4	SSR05050	H	

※ The information is for standard production, if required accuracy grade C5 or other needs, please contact **TBI MOTION**.

Nominal Model Code of Nut

G SFU R 025 05 T4 D + N3

① ② ③ ④ ⑤ ⑥ ⑦ ⑧

①

Product Code

②

Nominal Model

S : Single nut
D : Double nut

F : With flange
C : Without flange

NI : NI type nut
NU : NU type nut
H : H type nut

NH : NH nut
(A solution for slide table)

Y : Y type nut
V : V type nut

U : DIN nut
M : M type nut
K : K type nut

③

Threading Direction

R : Right
L : Left

④

Nominal Diameter

Unit : mm

⑤

Lead

Unit : mm

⑥

Number of Turns (Turn-Row)

Turn : T : 1

A : 1.5 (or 1.7/1.8)

B : 2.5/2.8

C : 3.5

D : 4.8

ex : (2.5 × 2 = B2)

⑦

Flange Type

N : Not cutting

S : Single cutting

D : Double cutting

⑧

Nut Surface Treatment

S : Standard

B1 : Black Oxidation

N1 : Hard Chrome Plating

P : Phosphating

N3 : Nickel Plating

N4 : Raydent

N5 : Chrome Plating

■ 2-3-4 Preload of Rolled Ball Screw

The standard preloading for Rolled Ball Screw is P0. If P1 preloading is required, please contact **TBI MOTION**.

Table2.3.4 Rolled screw accuracy

Unit : μm

Accuracy Grade	C5 (DIN)	C7	C10
e300	23	50	210

C

Ball Screw

TBI MOTION BALL SCREW

2-4 Rolled Ball Screw Series

2-4-1 TBI MOTION Nut of Rolled Ball Screw Type

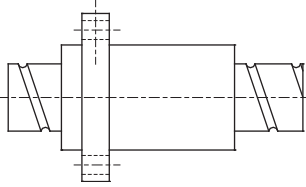
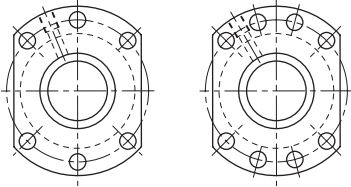
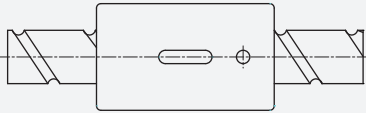
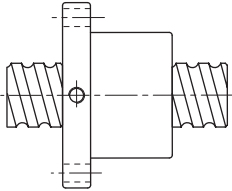
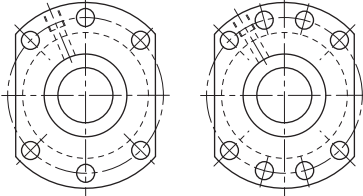
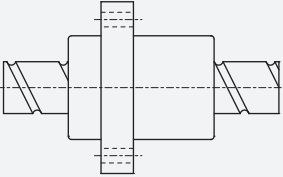
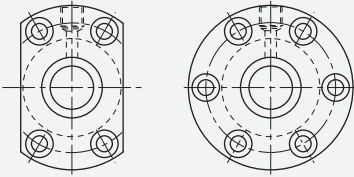
	Nut Type	Flange Type
NH/H (A solution for slide table/High Speed/Strong dust-proof type)	<p>SFNH/SFH(DIN)</p>  <p>C69</p>	 <p>$d \leq 32$ $d > 40$</p>
CNH (A solution for slide table)	<p>SCNH</p>  <p>C70</p>	No-Flange
NU (Strong dust-proof type)	<p>SFNU/SFU(DIN)</p>  <p>C71</p>	 <p>$d \leq 32$ $d > 40$</p>
NI/I (Strong dust-proof type)	<p>SFNI/SFI</p>  <p>C72</p>	

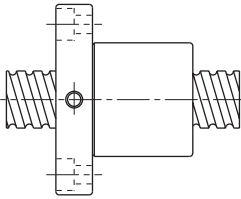
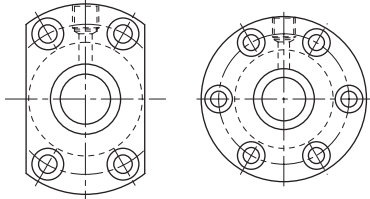
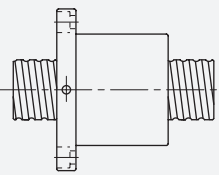
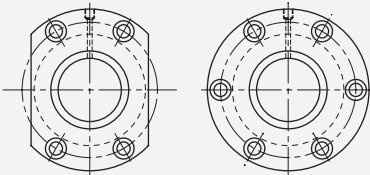
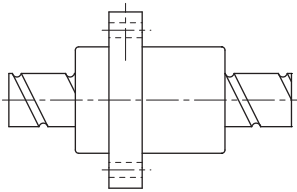
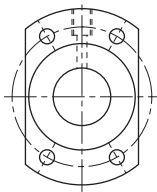
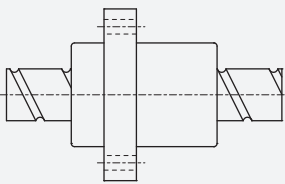
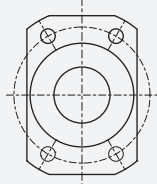
	Nut Type	Flange Type
M (Design for Milling)	<p>SFM</p>  <p>C72</p>	
> (High Load External Circulation type)	<p>SFV</p>  <p>C73</p>	
> (High DM-N Rating)	<p>SFY</p>  <p>C74</p>	
XSY (Miniature type)	<p>XSY</p>  <p>C75</p>	

TBI MOTION BALL SCREW

2-4 Rolled Ball Screw Series

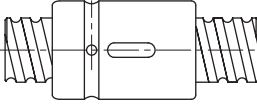
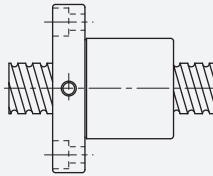
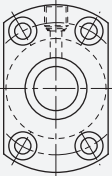
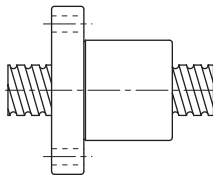
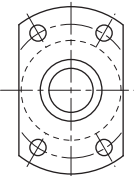
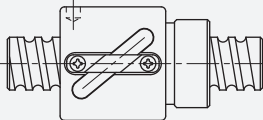
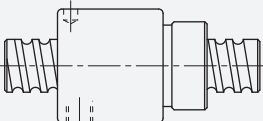
	Nut Type	Flange Type
CNI/I (Standard)	<p>SCNI/SCI</p>  <p>C76</p>	No-Flange
K (Miniature type)	<p>SFK</p>  <p>C77</p>	 <p>(SFK 01004) (SFK 02002) (SFK 02502)</p>
	<p>SFK</p>  <p>C77</p>	
BSH	<p>BSH</p>  <p>$d \leq 12$</p>  <p>$d \geq 14$</p> <p>C78</p>	No-Flange

※ The information is for specifications, if customized products are needed please contact **TBI MOTION**.

SFNH/SFH (DIN 69051 FORM B) Series Specifications

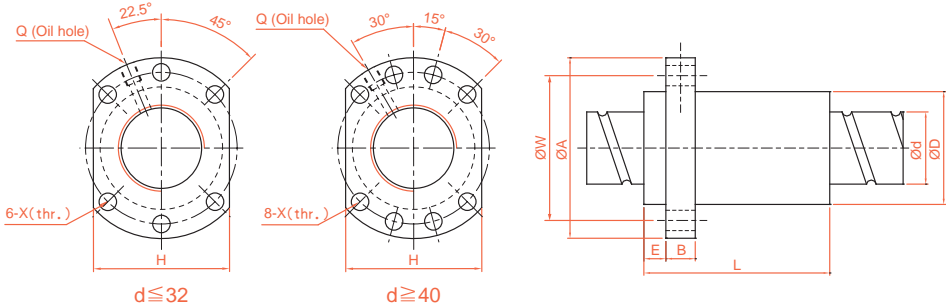

Unit : mm

Model No.	d	I	Da	Dimension										Load Rating		K kgf/μm
				D	A	E	B	L	W	H	X	Q	n	Ca (kgf)	Coa (kgf)	
SFH01205-2.8*	12	5	2.5	24	40	5	10	30	32	30	4.5		2.8x1	661	1316	19
SFH01210-2.8*		10	2.5	24	40	5	10	45	32	30	4.5		2.8x1	642	1287	19
SFH01605-3.8*	15	5	2.778	28	48	5	10	37	38	40	5.5	M6	3.8x1	1112	2507	30
SFH01610-2.8*		10	2.778	28	48	5	10	45	38	40	5.5	M6	2.8x1	839	1821	23
SFH01616-1.8*	15	16	2.778	28	48	5	10	45	38	40	5.5	M6	1.8x1	552	1137	14
SFH01616-2.8*		16	2.778	28	48	5	10	61	38	40	5.5	M6	2.8x1	808	1769	22
SFH01620-1.8*	15	20	2.778	28	48	7	10	58	38	40	5.5	M6	1.8x1	554	1170	14
SFH02005-3.8*		5	3.175	36	58	7	10	37	47	44	6.6	M6	3.8x1	1484	3681	37
SFH02010-3.8*	20	10	3.175	36	58	7	10	55	47	44	6.6	M6	3.8x1	1516	3833	40
SFH02020-1.8*		20	3.175	36	58	7	10	54	47	44	6.6	M6	1.8x1	764	1758	19
SFH02020-2.8*	20	20	3.175	36	58	7	10	74	47	44	6.6	M6	2.8x1	1118	2734	29
SFH02505-3.8*		5	3.175	40	62	7	10	37	51	48	6.6	M6	3.8x1	1650	4658	43
SFH02510-3.8*	25	10	3.175	40	62	7	12	55	51	48	6.6	M6	3.8x1	1638	4633	45
SFH02525-1.8*		25	3.175	40	62	7	12	64	51	48	6.6	M6	1.8x1	843	2199	22
SFH02525-2.8*	25	25	3.175	40	62	7	12	89	51	48	6.6	M6	2.8x1	1232	3421	34
SFH03205-3.8		5	3.175	50	80	9	12	37	65	62	9	M6	3.8x1	1839	6026	51
SFH03210-3.8	31	10	3.969	50	80	9	12	57	65	62	9	M6	3.8x1	2460	7255	55
SFH03220-2.8		20	3.969	50	80	9	12	76	65	62	9	M6	2.8x1	1907	5482	43
SFH03232-1.8	31	32	3.969	50	80	9	12	80	65	62	9	M6	1.8x1	1257	3426	27
SFH03232-2.8		32	3.969	50	80	9	12	112	65	62	9	M6	2.8x1	1838	5329	42
SFH04005-3.8	40	5	3.175	63	93	9	15	42	78	70	9	M8	3.8x1	2018	7589	60
SFH04010-3.8		10	6.35	63	93	9	14	60	78	70	9	M8	3.8x1	5035	13943	67
SFH04020-2.8	38	20	6.35	63	93	9	14	80	78	70	9	M8	2.8x1	3959	10715	54
SFH04040-1.8		40	6.35	63	93	9	14	98	78	70	9	M8	1.8x1	2585	6648	34
SFH04040-2.8	38	40	6.35	63	93	9	14	138	78	70	9	M8	2.8x1	3780	10341	52
SFH05005-3.8		50	5	3.175	75	110	10.5	15	42	93	85	11	M8	3.8x1	2207	9542
SFH05010-3.8	48	10	6.35	75	110	10.5	18	60	93	85	11	M8	3.8x1	5638	17852	79
SFH05020-3.8		20	6.35	75	110	10.5	18	100	93	85	11	M8	3.8x1	5749	18485	87
SFH05050-1.8	48	50	6.35	75	110	10.5	18	120	93	85	11	M8	1.8x1	2946	8749	42
SFH05050-2.8		50	6.35	75	110	10.5	18	170	93	85	11	M8	2.8x1	4308	13610	65

※ ★ Actuator type available (SFNH series).

TBI MOTION BALL SCREW

2-4 Rolled Ball Screw Series

SCNH Series Specifications

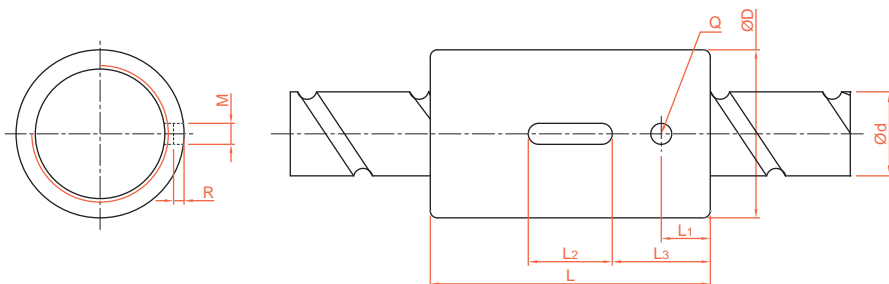

Unit : mm

Model No.	d	I	Da	Dimension									Load Rating		K kgf/μm
				D	L	L1	L2	L3	M	R	Q	n	Ca (kgf)	Coa (kgf)	
SCNH01205-4.8	12	5	2.5	24	40	7	12	14	3	1.5	3	4.8x1	1051	2255	34
SCNH01210-2.8		10	2.5	24	45	8	15	15	3	1.5	3	2.8x1	642	1287	19
XCNH01210-1.8		10	2.5	24	40	10.5	12	14	3	1.5	3	1.8x1	439	827	33
SCNH01605-5.8	15	5	2.778	28	45	7	20	12.5	5	3	3	5.8x1	1599	3827	49
SCNH01610-2.8		10	2.778	28	45	7	20	12.5	5	3	3	2.8x1	839	1821	23
SCNH01616-1.8		16	2.778	28	45	7	20	12.5	5	3	3	1.8x1	552	1137	18
SCNH01620-1.8		20	2.778	28	58	10	20	19	5	3	3	1.8x1	554	1170	14
SCNH02005-5.8	20	5	3.175	36	47	8	20	13.5	5	3	3	5.8x1	2134	5619	60
SCNH02010-3.8		10	3.175	36	55	8	20	17.5	5	3	3	3.8x1	1516	3833	40
SCNH02020-1.8		20	3.175	36	55	8	20	17.5	5	3	3	1.8x1	764	1758	19

SFNU/SFU (DIN 69051 FORM B) Series Specifications

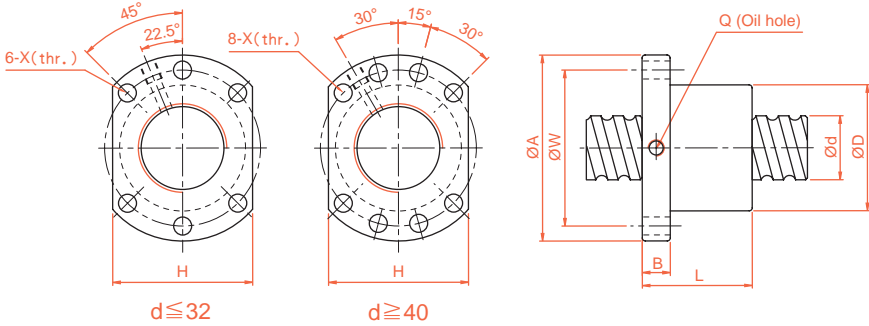

Unit : mm

Model No.	d	I	Da	Dimension									Load Rating		K kgf/ µm
				D	A	B	L	W	H	X	Q	n	Ca (kgf)	Coa (kgf)	
SFNU01605-4*	16	5	3.175	28	48	10	45	38	40	5.5	M6	1x4	1380	3052	32
SFNU01610-3*		10	3.175	28	48	10	57	38	40	5.5	M6	1x3	1103	2401	26
SFNU02005-4*	20	5	3.175	36	58	10	51	47	44	6.6	M6	1x4	1551	3875	39
SFNU02505-4*		5	3.175	40	62	10	51	51	48	6.6	M6	1x4	1724	4904	45
SFNU02510-4*	25	10	4.762	40	62	12	80	51	48	6.6	M6	1x4	2954	7295	50
SFNU03205-4*		5	3.175	50	80	12	52	65	62	9	M6	1x4	1922	6343	54
SFNU03210-4*	32	10	6.35	50	80	12	85	65	62	9	M6	1x4	4805	12208	61
SFNU04005-4*		5	3.175	63	93	14	55	78	70	9	M8	1x4	2110	7988	63
SFNU04010-4*	40	10	6.35	63	93	14	88	78	70	9	M8	1x4	5399	15500	73
SFNU05010-4*		10	6.35	75	110	16	88	93	85	11	M8	1x4	6004	19614	85
SFNU06310-4*	63	10	6.35	90	125	18	93	108	95	11	M8	1x4	6719	25358	99
SFNU08010-4*		10	6.35	105	145	20	93	125	110	13.5	M8	1x4	7346	31953	109
SFU01204-4	12	4	2.5	24	40	10	40	32	30	4.5		1x4	902	1884	26
SFU01604-4		4	2.381	28	48	10	40	38	40	5.5	M6	1x4	973	2406	32
SFU02004-4	20	4	2.381	36	58	10	42	47	44	6.6	M6	1x4	1066	2987	38
SFU02504-4		4	2.381	40	62	10	42	51	48	6.6	M6	1x4	1180	3795	43
SFU02506-4	25	6	3.969	40	62	10	54	51	48	6.6	M6	1x4	2318	6057	47
SFU02508-4		8	4.762	40	62	10	63	51	48	6.6	M6	1x4	2963	7313	49
SFU03204-4	32	4	2.381	50	80	12	44	65	62	9	M6	1x4	1296	4838	51
SFU03206-4		6	3.969	50	80	12	57	65	62	9	M6	1x4	2632	7979	57
SFU03208-4	32	8	4.762	50	80	12	65	65	62	9	M6	1x4	3387	9622	60
SFU04006-4		6	3.969	63	93	14	60	78	70	9	M6	1x4	2873	9913	66
SFU04008-4	40	8	4.762	63	93	14	67	78	70	9	M6	1x4	3712	11947	70
SFU05020-4		20	7.144	75	110	16	138	93	85	11	M8	1x4	7142	22588	94
SFU06320-4	63	20	9.525	95	135	20	149	115	100	13.5	M8	1x4	11444	36653	112
SFU08020-4		20	9.525	125	165	25	154	145	130	13.5	M8	1x4	12911	47747	138
SFU10020-4	100	20	9.525	150	202	30	180	170	155	17.5	M8	1x4	14303	60698	162

※ ☆ Left helix available

TBI MOTION BALL SCREW

2-4 Rolled Ball Screw Series

SFNI/SFI Series Specifications

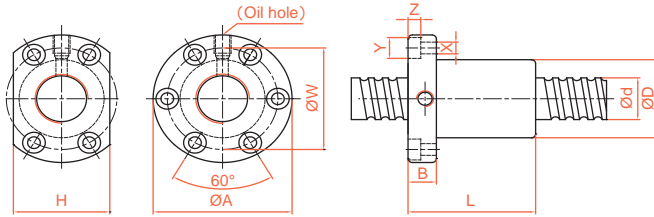

Unit : mm

Model No.	d	I	Da	Dimension											Load Rating		K kgf/μm
				D	A	B	L	W	H	X	Y	Z	Q	n	Ca (kgf)	Coa (kgf)	
SFNI01605-4*	16	5	3.175	30	49	10	45	39	34	4.5	8	4.5	M6	1x4	1380	3052	33
SFNI01610-3*		10	3.175	34	58	10	57	45	34	5.5	9.5	5.5	M6	1x3	1103	2401	27
SFNI02005-4*	20	5	3.175	34	57	11	51	45	40	5.5	9.5	5.5	M6	1x4	1551	3875	39
SFNI02505-4*		5	3.175	40	63	11	51	51	46	5.5	9.5	5.5	M8	1x4	1724	4904	45
SFNI02510-4*	25	10	4.762	46	72	12	80	58	52	6.5	11	6.5	M6	1x4	2954	7295	51
SFNI03205-4*		5	3.175	46	72	12	52	58	52	6.5	11	6.5	M8	1x4	1922	6343	52
SFNI03210-4*	32	10	6.35	54	88	15	85	70	62	9	14	8.5	M8	1x4	4805	12208	62
SFNI04005-4*		5	3.175	56	90	15	55	72	64	9	14	8.5	M8	1x4	2110	7988	59
SFNI04010-4*	40	10	6.35	62	104	18	88	82	70	11	17.5	11	M8	1x4	5399	15500	72
SFNI05010-4*		50	6.35	72	114	18	88	92	82	11	17.5	11	M8	1x4	6004	19614	83
SFNI06310-4*	63	10	6.35	85	131	22	93	107	95	14	20	13	M8	1x4	6719	25358	95
SFNI08010-4		80	6.35	105	150	22	93	127	115	14	20	13	M8	1x4	7346	31953	109
SFI01604-4	16	4	2.381	30	49	10	45	39	34	4.5	8	4.5	M6	1x4	973	2406	32
SFI02004-4		4	2.381	34	57	11	46	45	40	5.5	9.5	5.5	M6	1x4	1066	2987	37
SFI0205T-4	20	5.08	3.175	34	57	11	51	45	40	5.5	9.5	5.5	M6	1x4	1550	3875	39
SFI02504-4		4	2.381	40	63	11	46	51	46	5.5	9.5	5.5	M6	1x4	1180	3795	43
SFI0255T-4	25	5.08	3.175	40	63	11	51	51	46	5.5	9.5	5.5	M8	1x4	1724	4903	45
SFI03204-4		32	4	2.381	46	72	12	47	58	52	6.5	11	6.5	M6	1x4	1296	4838

SFM Series Specifications (Design for Milling)

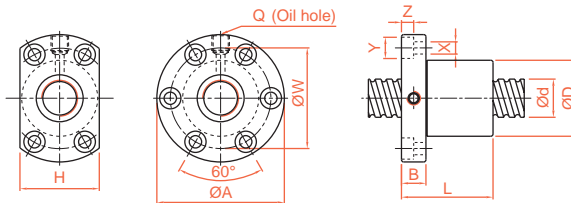

Unit : mm

Model No.	d	I	Da	Dimension											Load Rating		K kgf/μm
				D	A	B	L	W	H	X	Y	Z	Q	n	Ca (kgf)	Coa (kgf)	
SFM03205-4*	32	5	3.175	48	74	12	52	60	60	6.5	11	6.5	M8	1x4	1922	6343	53
SFM0325T-4*		5.08	3.175	48	74	12	53	60	60	6.5	11	6.5	M8	1x4	1922	6343	53

※ ☆ Left helix available

SFV Series Specifications

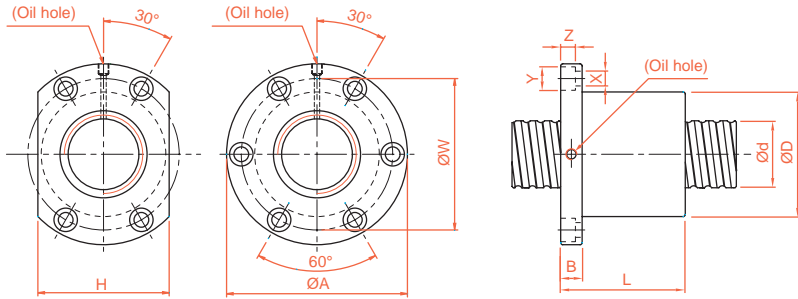

Unit : mm

Model No.	d	I	Da	Dimension											Load Rating		K kgf/μm
				D	A	B	L	W	H	X	Y	Z	Q	n	Ca (kgf)	Coa (kgf)	
SFV01205-2.8	12	5	2.5	30	50	10	42	40	32	4.5	8	4.5	M6	2.8x1	661	1316	19
SFV01210-2.7		10	2.5	30	50	10	53	40	32	4.5	8	4.5	M6	2.7x1	623	1241	18
SFV01604-3.8	16	4	2.381	34	57	11	45	45	34	5.5	9.5	5.5	M6	3.8x1	931	2285	31
SFV01605-4.8		5	3.175	40	63	11	58	51	42	5.5	9.5	5.5	M6	4.8x1	1614	3662	40
SFV01610-2.7		10	3.175	40	63	11	56	51	42	5.5	9.5	5.5	M6	2.7x1	1008	2161	24
SFV02004-4.8	20	4	2.381	40	60	10	50	50	40	4.5	8	4	M6	4.8x1	1247	3584	45
SFV02005-4.8		5	3.175	44	67	11	57	55	52	5.5	9.5	5.5	M6	4.8x1	1814	4650	47
SFV02010-2.7		10	3.969	46	74	13	57	59	46	6.6	11	6.5	M6	2.7x1	1518	3398	30
SFV02020-1.8		20	3.175	46	74	13	70	59	46	6.6	11	6.5	M6	1.8x1	764	1758	19
SFV02505-4.8	25	5	3.175	50	73	11	55	61	52	5.5	9.5	5.5	M8	4.8x1	2017	5884	56
SFV02525-1.8		25	3.175	50	73	13	83	61	52	5.5	9.5	5.5	M8	1.8x1	843	2199	22
SFV03204-4.8	32	4	2.381	54	81	12	50	67	64	6.6	11	6.5	M6	4.8x1	1517	5806	62
SFV03205-4.8		5	3.175	58	85	12	56	71	64	6.6	11	6.5	M8	4.8x1	2249	7612	66
SFV03210-4.8		10	6.35	74	108	15	96	90	82	9	14	9	M8	4.8x1	5620	14649	76
SFV04005-4.8	40	5	3.175	67	101	15	59	83	72	9	14	8.5	M8	4.8x1	2468	9586	76
SFV04010-4.8		10	6.35	82	124	18	100	102	94	11	17.5	11	M8	4.8x1	6316	18600	90
SFV04020-2.7		20	6.35	82	124	18	100	102	90	11	17.5	11	M8	2.7x1	3935	10893	56
SFV05005-4.8	50	5	3.175	80	114	15	60	96	82	9	14	8.5	M8	4.8x1	2698	12053	87
SFV05010-4.8		10	6.35	93	135	16	93	113	98	11	17.5	11	M8	4.8x1	7023	23537	106
SFV05020-2.7		20	9.525	105	152	28	121	128	110	14	20	13	M8	2.7x1	7336	19700	68
SFV06310-4.8	63	10	6.35	108	154	22	105	130	110	14	20	13	M8	4.8x1	7860	30430	126
SFV06320-2.7		20	9.525	122	180	28	120	150	130	18	26	17.5	M8	2.7x1	8162	24741	80
SFV08010-4.8	80	10	6.35	130	176	22	105	152	132	14	20	13	M8	4.8x1	8593	38344	145
SFV08020-4.8		20	9.525	143	204	28	180	172	148	18	26	18	M8	4.8x1	15103	57296	168
SFV08020-7.6		20	9.525	143	204	28	240	172	148	18	26	18	M8	3.8x2	22423	90719	260

TBI MOTION BALL SCREW

2-4 Rolled Ball Screw Series

SFY Series Specifications

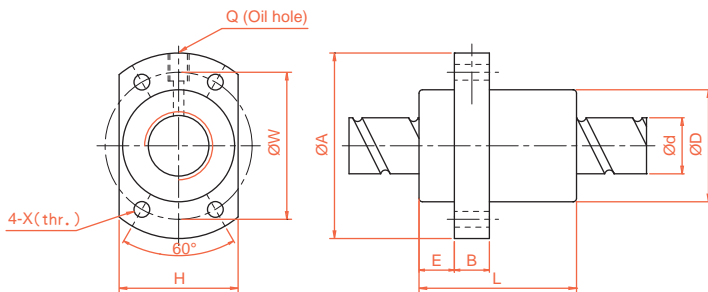

Unit : mm

Large Lead Model No.	d	I	Da	Dimension										Load Rating		K kgf/μm
				D	A	E	B	L	W	H	X	Q	n	Ca (kgf)	Coa (kgf)	
SFY01616-3.6	16	16	2.778	32	53	10.1	10	45	42	34	4.5	M6	1.8x2	1073	2551	31
SFY02020-3.6	20	20	3.175	39	62	13	10	52	50	41	5.5	M6	1.8x2	1387	3515	37
SFY02525-3.6	25	25	3.969	47	74	15	12	64	60	49	6.6	M6	1.8x2	2074	5494	45
SFY03232-3.6	32	32	4.762	58	92	17	12	78	74	60	9	M6	1.8x2	3021	8690	58
SFY04040-3.6	40	40	6.35	73	114	19.5	15	99	93	75	11	M6	1.8x2	4831	14062	70
SFY05050-3.6	50	50	7.938	90	135	21.5	20	117	112	92	14	M6	1.8x2	7220	21974	86
Twin Lead Model No.	d	I	Da	Dimension										Ca (kgf)	Coa (kgf)	K kgf/μm
SFY01632-1.6	16	32	2.778	32	53	10.1	10	42.5	42	34	4.5	M6	0.8x2	493	1116	11
SFY02040-1.6	20	40	3.175	39	62	13	10	48	50	41	5.5	M6	0.8x2	653	1597	15
SFY02550-1.6	25	50	3.969	47	74	15	12	58	60	49	6.6	M6	0.8x2	976	2495	19
SFY03264-1.6	32	64	4.762	58	92	17	12	71	74	60	9	M6	0.8x2	1374	3571	22
SFY04080-1.6	40	80	6.35	73	114	19.5	15	90	93	75	11	M6	0.8x2	2273	6387	29
SFY050100-1.6	50	100	7.938	90	135	21.5	20	111	112	92	14	M6	0.8x2	3398	9980	35

XSY Series Specifications

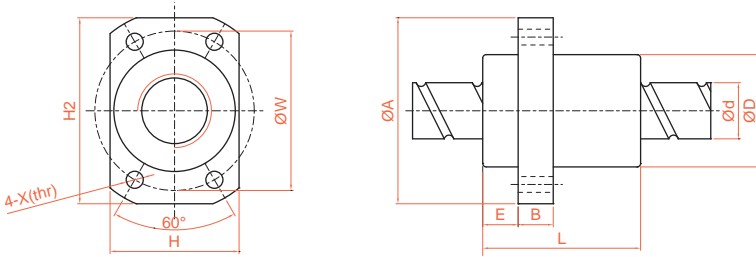

Unit : mm

Model No.	d	I	Da	Dimension										Load Rating		K kgf/μm
				D	A	E	B	L	W	H	H2	X	n	Ca (kgf)	Coa (kgf)	
XSYR01220A2D-00	12	20	2.5	24	41	3.8	5	50	32	24	36	4.5	1.8x2	777	1718	13

TBI MOTION BALL SCREW

2-4 Rolled Ball Screw Series

SCNI/SCI Series Specifications

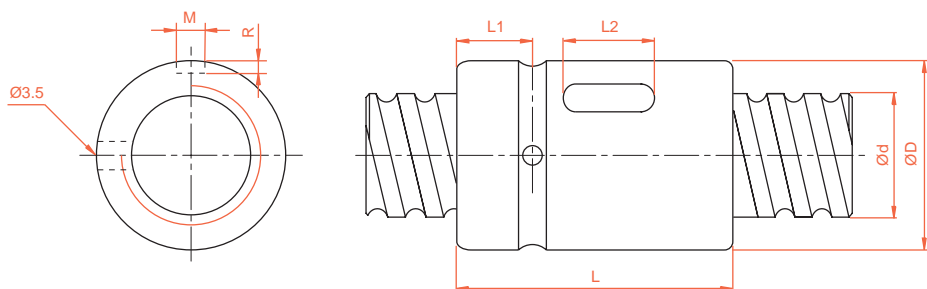

Unit : mm

Model No.	d	I	Da	Dimension							Load Rating		K kgf/μm
				D	L	L1	L2	M	R	n	Ca (kgf)	Coa (kgf)	
SCNI 01605-4	16	5	3.175	30	45	9	20	5	3	1x4	1380	3052	33
SCNI 02005-4	20	5	3.175	34	45	9	20	5	3	1x4	1551	3875	39
SCNI 02505-4	25	5	3.175	40	45	9	20	5	3	1x4	1724	4904	45
SCNI 02510-4		10	4.762	46	85	13	30	5	3	1x4	2954	7295	51
SCNI 03205-4	32	5	3.175	46	45	9	20	5	3	1x4	1922	6343	52
SCNI 03210-4		10	6.35	54	85	13	30	5	3	1x4	4805	12208	62
SCNI 04005-4	40	5	3.175	56	45	9	20	5	3	1x4	2110	7988	59
SCNI 04010-4		10	6.35	62	85	13	30	5	3	1x4	5399	15500	72
SCNI 05010-4	50	10	6.35	72	85	13	30	5	3	1x4	6004	19614	83
SCNI 06310-4	63	10	6.35	85	85	13	30	6	3.5	1x4	6719	25358	95
SCNI 08010-4	80	10	6.35	105	85	13	30	8	4.5	1x4	7346	31953	109
SCI 01604-4	16	4	2.381	30	40	9	15	3	1.5	1x4	973	2406	32
SCI 02004-4	20	4	2.381	34	40	9	15	3	1.5	1x4	1066	2987	37
SCI 02504-4	25	4	2.381	40	40	9	15	3	1.5	1x4	1180	3795	43
SCI 03204-4	32	4	2.381	46	40	9	15	3	1.5	1x4	1296	4838	49

SFK Series Specifications

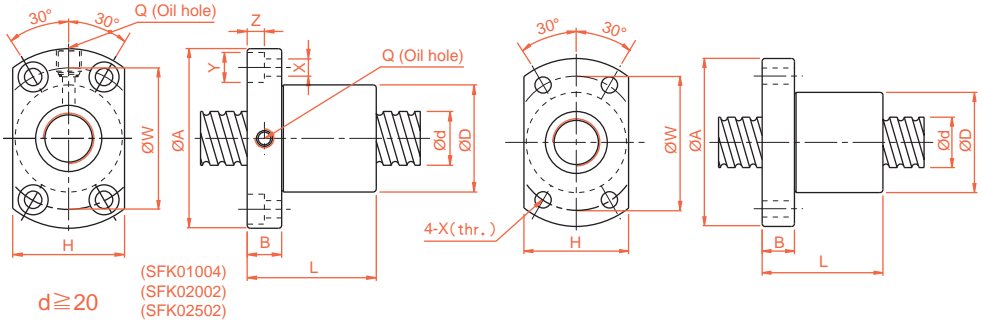

Unit : mm

Model No.	d	I	Da	Dimension											Ca (kgf)	Coa (kgf)	K kgf/ μ m	
				D	A	B	L	W	H	X	Y	Z	Q	n				
SFK00601	6	1	0.8	12	24	3.5	15	18	16	3.4	-	-	-	1x3	111	224	9	
SFK00801	8	1	0.8	14	27	4	16	21	18	3.4	-	-	-	1x4	161	403	14	
SFK00802		2	1.2	14	27	4	16	21	18	3.4	-	-	-	1x3	222	458	13	
SFK0082.5		2.5	1.2	16	29	4	26	23	20	3.4	-	-	-	1x3	221	457	13	
SFK01002		2	1.2	18	35	5	28	27	22	4.5	-	-	-	1x3	243	569	15	
SFK01004	10	4	2	26	46	10	34	36	28	4.5	8	4.5	M6	1x3	468	905	17	
SFK01202		12	2	1.2	20	37	5	28	29	24	4.5	-	-	-	1x4	334	906	22
SFK01402		14	2	1.2	21	40	6	23	31	26	5.5	-	-	-	1x4	354	1053	24

Unit : mm

Model No.	d	I	Da	Dimension											Ca (kgf)	Coa (kgf)	K kgf/ μ m
				D	A	B	L	W	H	X	Y	Z	Q	n			
XSUR01204T3D-02	12	4	2.5	24	40	6	28	32	25	3.5	-	-	-	1x3	704	1413	-
XSUR01205T3D-00		5		22	37	8	39	29	24	4.5	-	-	-	1x3	702	1409	17

TBI MOTION BALL SCREW

2-1 Nominal Model Code of Ball Screw

BSH Series Specifications

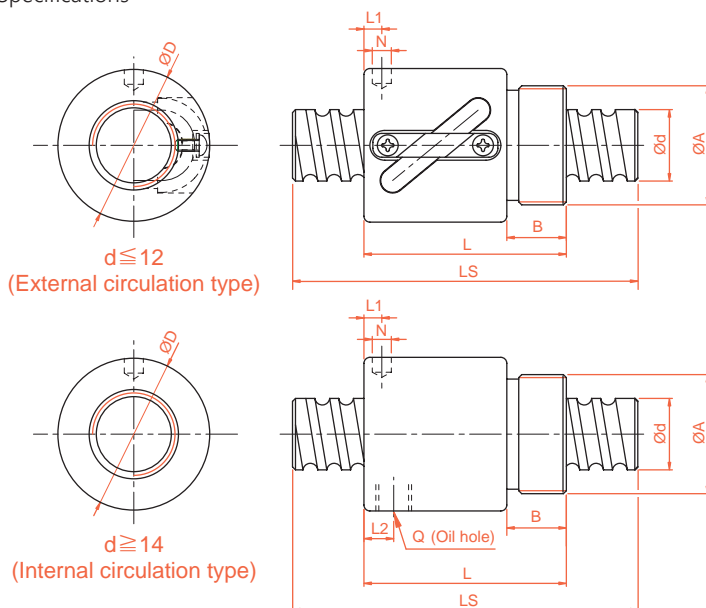

Unit : mm

Model No.	d	I	Da	Dimension									Ca (kgf)	Coa (kgf)	K kgf/ μ m
				D	A	B	L	L1	N	L2	Q	n			
BSHR0082.5-2.5	8	2.5	1.2	17.5	M15x1P	7.5	23.5	10	3	-	-	2.5x1	189	381	11
BSHR01002-3.5	10	2	1.2	19.5	M17x1P	7.5	22	3	3.2	-	-	3.5x1	277	664	17
BSHR01004-2.5		4	2	25	M20x1P	10	34	3	3	-	-	2.5x1	400	754	14
BSHR01204-3.5	12	4	2.5	25.5	M20x1P	10	34	13	3	-	-	3.5x1	804	1649	23
BSHR01205-3.5		5	2.5	25.5	M20x1P	10	39	16.25	3	-	-	3.5x1	801	1644	24
BSHR01404-3	14	4	2.5	32.1	M25x1.5P	10	35	11	3	-	-	1x3	748	1609	26
BSHR01604-3	16	4	2.381	29	M22x1.5P	8	32	4	3.2	-	-	1x3	759	1804	24
BSHR01605-3		5	3.175	32.5	M26x1.5P	12	42	19.25	3	-	-	1x3	1077	2289	25
BSHR01610-2		10	3.175	32	M26x1.5P	12	50	3	4	3	M4	1x2	779	1601	14
BSHR02005-3	20	5	3.175	38	M35x1.5P	15	45	20.3	3	-	-	1x3	1211	2906	30
BSHR02505-4	25	5	3.175	43	M40x1.5P	19	69	32.11	3	8	M6	1x4	1724	4904	37
BSHR02510-4		10	4.762	43	M40x1.5P	19	84	8	6	8	M6	1x4	2954	7295	41

* Standard ballnut from $\varnothing 8$ ~ $\varnothing 16$ is assembled without wiper.

Rotary Series



1-1 Features of TBI MOTION Precision Rotary Ball Screw/Spline	D02
1-2 Accuracy	D05
1-2-1 RBBY, RBLY Accuracy StandardsD05
1-2-2 RFBY Accuracy StandardsD06
1-2-3 RSSY, RSLY Accuracy StandardsD07
1-2-4 RFSY Accuracy StandardsD07
1-2-5 RLBF, RLSF Accuracy StandardsD08
1-3 Example of Assembly - RFBY	D10
1-3-1 Example of Mounting Rotary Ball Screw Nut Model RFBYD10
1-4 Example of Assembly - RBBY	D11
1-4-1 Example of Mounting Precision Ball Screw/Spline Model RBBYD11
1-5 Nominal Model Code of Rotary Series	D12

ABOUT PRECISION ROTARY BALL

1-1 Features of *TBI MOTION* Precision Rotary Ball Screw/Spline

TBI MOTION rotary ball screw and spline is designed to move linearly and rotationally in one assembly, with symmetrical orientation design between the outer and inner ball screw or spline nut. Both rotary and spiral movement can be achieved simultaneously.

TBI MOTION rotary line is the most ideal key component in scara robots, industrial robots, pick & place, laser engraving, transporting and many other multi-directional application.

Feature

Zero clearance/High rigidity

TBI MOTION rotary series featured 40° angular (Back to back) contact angle within in the bearing. It enables self-aligning with minor mounting error and bears higher axial load to achieve better accuracy. Custom preload can be applied to reduce clearance and increase high rigidity. (as shown in Fig 1.1.1)

High speed/Smooth running performance

The rotary series uses *TBI MOTION* high lead screw to maintain high speed and smoothness during operating.

Noise reduction

The precision ground screw thread and spline groove make sure the ball bearing travel fluently during operations which reduce the skidding, friction and noise level and thus improve the service performance and life.

Easy-Assembly/Compactness

TBI MOTION rotary line features a one-piece compact and easy mounting design.

Accuracy

Please refer to chart D05~09 for detail.

Spline alternative

TBI MOTION offers customized end for ball spline. Hollow spline is also available for special operation requirement such as pipe or wire-arrangement, evacuating and light weight.

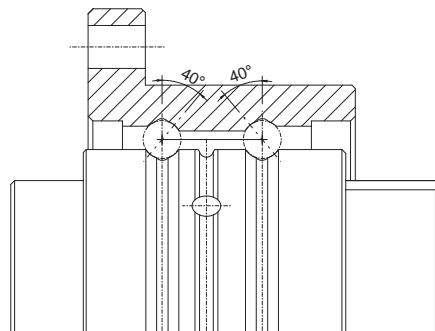
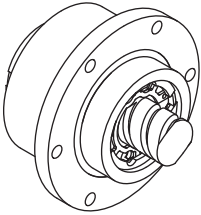
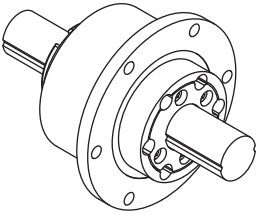
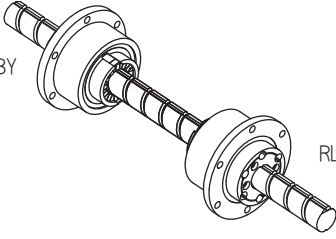
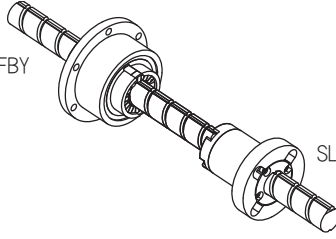

Fig 1.1.1 DB-type (Back to back)

SCREW/SPLINE

Table 1.1.1 Mass series

Rotary Ball Screw - RFBY Type	Rotary Ball Spline - RLBF Type
	
Ball Screw/Spline - RBBY Type	Ball Screw/Spline - RBLY Type
	

D Rotary Ball Screw/Spline

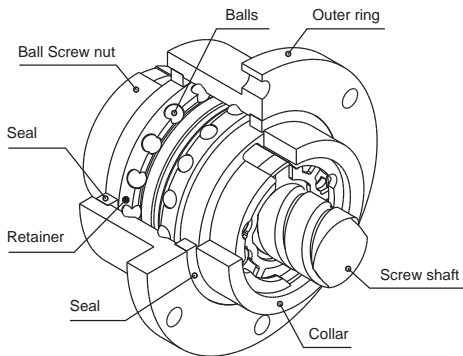

Fig 1.1.2 The Structure of RFBY - series

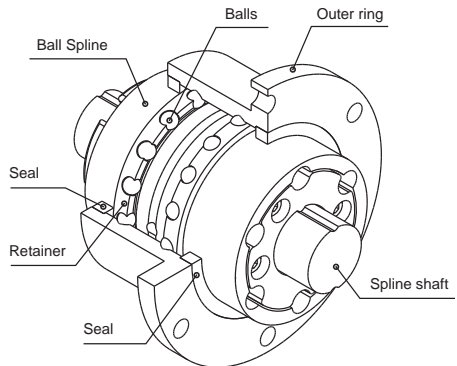
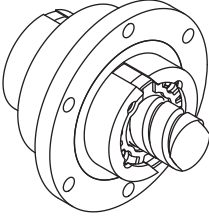
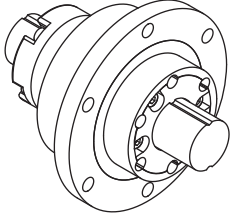
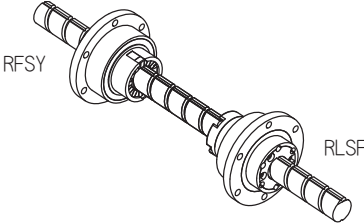
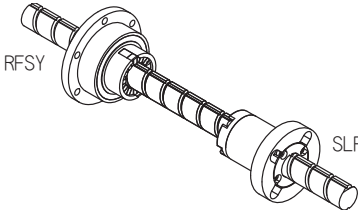

Fig 1.1.3 The Structure of RLBF - series

ABOUT PRECISION ROTARY BALL

1-1 Features of *TBI MOTION* Precision Rotary Ball Screw/Spline

Table 1.1.2 Compact series

Rotary Ball Screw - RFSY Type	Rotary Ball Spline - RLSF Type
	
Ball Screw/Spline - RSSY Type	Ball Screw/Spline - RSLY Type
	

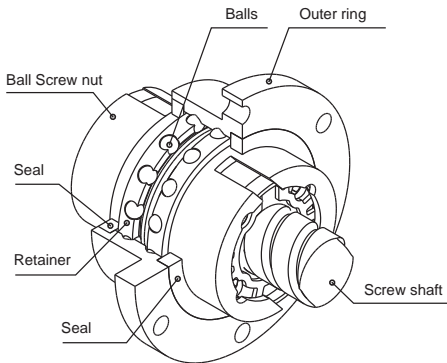

Fig 1.1.4 The Structure of RFSY - series

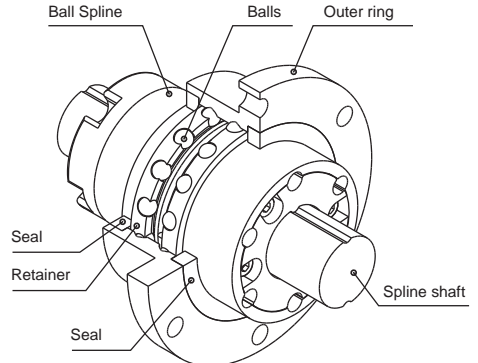

Fig 1.1.5 The Structure of RLSF - series

SCREW/SPLINE

1-2 Accuracy

■ 1-2-1 RBBY, RBL Y Accuracy Standards

The Ball Screw/Spline is manufactured as the following specifications.

【Ball Screw】

Axial clearance : 0 or less

Lead accuracy : C5

(Refer to C06 for more details)

【Ball Spline】

Clearance in the rotational direction : 0 or less

(P1 : light preload)

(Refer to B20-21 for more details)

Accuracy grade : class H

(Refer to B22 for more details)

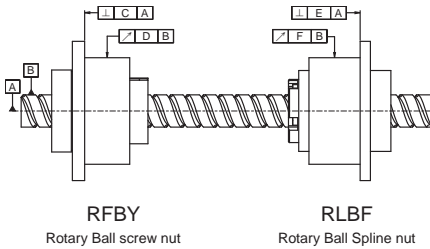

Fig 1.2.1 RBBY - series

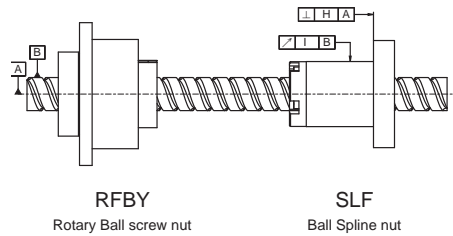

Fig 1.2.2 RBL Y - series

Model No.	C	D	E	F	H	I
RBBY01616 RBL Y01616	0.018	0.021	0.016	0.020	0.013	0.016
RBBY02020 RBL Y02020	0.018	0.021	0.016	0.020	0.013	0.016
RBBY02525 RBL Y02525	0.021	0.021	0.018	0.024	0.016	0.016
RBBY03232 RBL Y03232	0.021	0.021	0.018	0.024	0.016	0.016
RBBY04040 RBL Y04040	0.025	0.025	0.021	0.033	0.019	0.019
RBBY05050 RBL Y05050	0.025	0.025	0.021	0.033	0.019	0.019

ABOUT PRECISION ROTARY BALL

1-2 Accuracy

■ 1-2-2 RFBY Accuracy Standards

The accuracy of model RFBY is according to JIS standard (JIS B 1192-1997) except for the circular runout of Ball Screw axis(D) and the perpendicularity of the flange-mounting surface against the screw axis (C).

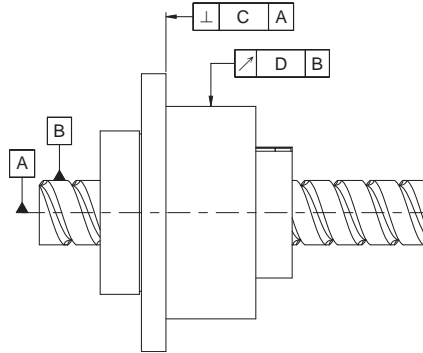

Fig 1.2.3 RFBY - series

Unit : mm

Lead angle accuracy	Rolled C7		Rolled C10		Ground C7		Ground C5		Ground C3	
	C	D	C	D	C	D	C	D	C	D
RFBY01616	0.035	0.065	0.035	0.065	0.023	0.035	0.016	0.020	0.013	0.017
RFBY02020	0.035	0.065	0.035	0.065	0.023	0.035	0.016	0.020	0.013	0.017
RFBY02525	0.035	0.065	0.035	0.065	0.023	0.035	0.018	0.024	0.015	0.020
RFBY03232	0.035	0.065	0.035	0.065	0.023	0.035	0.018	0.024	0.015	0.020
RFBY04040	0.046	0.086	0.046	0.086	0.026	0.046	0.021	0.033	0.018	0.026
RFBY05050	0.046	0.086	0.046	0.086	0.026	0.046	0.021	0.033	0.018	0.026

SCREW/SPLINE

■ 1-2-3 RSSY, RSLY Accuracy Standards

The Ball Screw/Spline is manufactured as the following specifications.

【Ball Screw】

Axial clearance : 0 or less

Lead accuracy : C5

(Refer to C06 for more details)

【Ball Spline】

Clearance in the rotational direction : 0 or less

(P1 : light preload)

(Refer to B20-21 for more details)

Accuracy grade : class H

(Refer to B22 for more details)

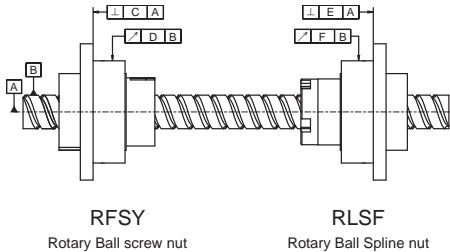

RSSY
Rotary Ball screw nut

RLSF
Rotary Ball Spline nut

Fig 1.2.4 RSSY - series

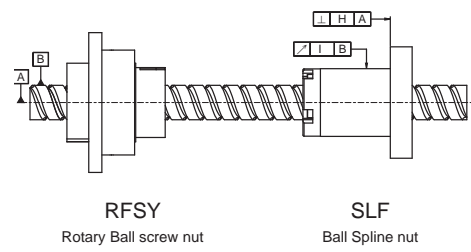

RFSY
Rotary Ball screw nut

SLF
Ball Spline nut

Fig 1.2.5 RSLY - series

Model No.	C	D	E	F	H	I
RSSY01616 RSLY01616	0.018	0.021	0.016	0.020	0.013	0.016
RSSY02020 RSLY02020	0.018	0.021	0.016	0.020	0.013	0.016
RSSY02525 RSLY02525	0.021	0.021	0.018	0.024	0.016	0.016
RSSY03232 RSLY03232	0.021	0.021	0.018	0.024	0.016	0.016
RSSY04040 RSLY04040	0.025	0.025	0.021	0.033	0.019	0.019

■ 1-2-4 RFSY Accuracy Standards

The accuracy of model RFBY is according to JIS standard (JIS B 1192-1997) except for the circular runout of Ball Screw axis(D) and the perpendicularity of the flange-mounting surface against the screw axis (C).

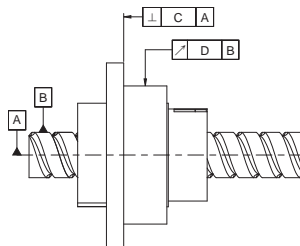

Fig 1.2.3 RFBY - series

ABOUT PRECISION ROTARY BALL

1-2 Accuracy

Unit : mm

Lead angle accuracy	Rolled C7		Rolled C10		Ground C7		Ground C5		Ground C3	
	C	D	C	D	C	D	C	D	C	D
Model No.										
RFSY01616	0.035	0.065	0.035	0.065	0.023	0.035	0.016	0.020	0.013	0.017
RFSY02020	0.035	0.065	0.035	0.065	0.023	0.035	0.016	0.020	0.013	0.017
RFSY02525	0.035	0.065	0.035	0.065	0.023	0.035	0.018	0.024	0.015	0.020
RFSY03232	0.035	0.065	0.035	0.065	0.023	0.035	0.018	0.024	0.015	0.020
RFSY04040	0.046	0.086	0.046	0.086	0.026	0.046	0.021	0.033	0.018	0.026

1-2-5 RLBF, RLSF Accuracy Standards

Accuracy Grades

The accuracy of the Ball Spline is determined by the nodding action of the spline-nut and classified into three accuracy class : Normal(N), High(H) and Precision(P).

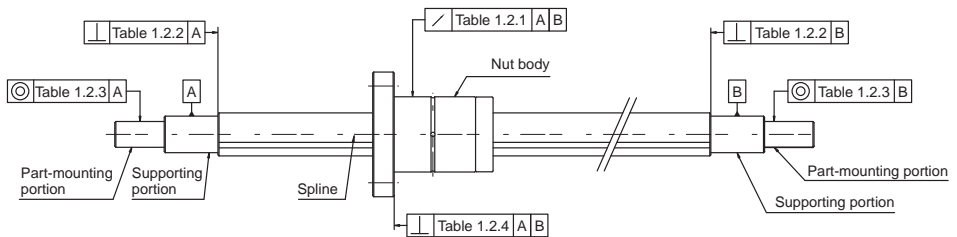

Fig 1.2.7

Accuracy Specification

Tables 1.2.1 ~ 5 indicate the the measurement items of Ball Spline.

Table 1.2.1 The Maximum nodding action of Spline Nut on the support unit.

Unit : μm

Length	Nominal Diameter		16, 20			25, 32			40, 50		
	Above	Below	N	H	P	N	H	P	N	H	P
-		200	56	34	18	53	32	18	53	32	16
200		315	71	45	25	58	39	21	58	36	19
315		400	83	53	31	70	44	25	63	39	21
400		500	95	62	38	78	50	29	68	43	24
500		630	112	-	-	88	57	34	74	47	27
630		800	-	-	-	103	68	42	84	54	32

SCREW/SPLINE

D

Rotary Ball Screw/Spline

Table1.2.2 The Maximum perpendicularity of Spline-shaft end on the support unit.

Unit : μm

Nominal Diameter		Accuracy		
		Normal (N)	High (H)	Precision (P)
16	20	27	11	8
25	32	33	13	9
40	50	39	16	11

Table1.2.3 The concentricity between components assembly part and attach surface.

Unit : μm

Nominal Diameter		Accuracy		
		Normal (N)	High (H)	Precision (P)
16	20	46	19	12
25	32	53	22	13
40	50	62	25	15

Table1.2.4 The perpendicularity of flange on the attach surface

Unit : μm

Nominal Diameter				Accuracy		
				Normal (N)	High (H)	Precision (P)
16	20	25	32	30	16	11
40	50			46	19	13

Table1.2.5 The accuracy grade on the effective length accuracy

Unit : μm

Accuracy	Normal (N)	High (H)	Precision (P)
Permissible Value	33	13	6

Note : Measurement only applies to any 100mm on the Spline shaft.

ABOUT PRECISION ROTARY BALL

1-3 Example of Assembly - RFBY

■ 1-3-1 Example of Mounting Rotary Ball Screw Nut Model RFBY

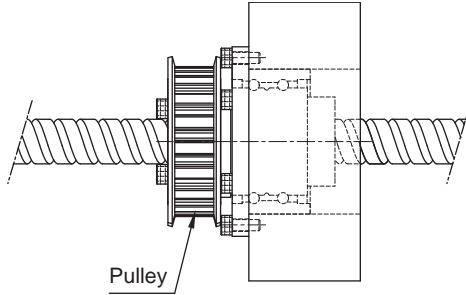

Fig 1.3.1

Example of Mounting Model RFBY

(1) Ball screw nut fixed, screw shaft floated. (Suitable for a long table)

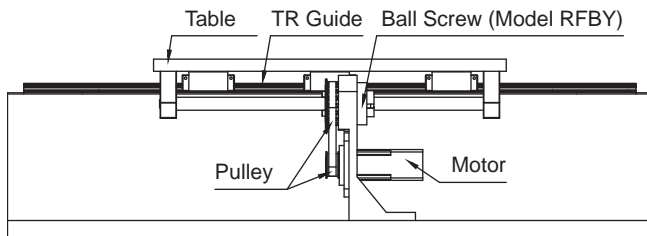

Fig 1.3.2

(2) Ball screw nut floated, screw shaft fixed. (Suitable for a short table and a long stroke)

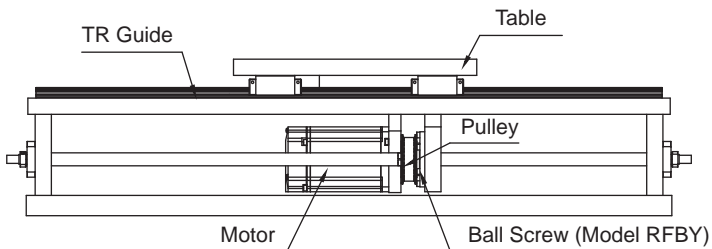

Fig 1.3.3

1-4 Example of Assembly - RBBY

■ 1-4-1 Example of Mounting Precision Ball Screw/Spline Model RBBY

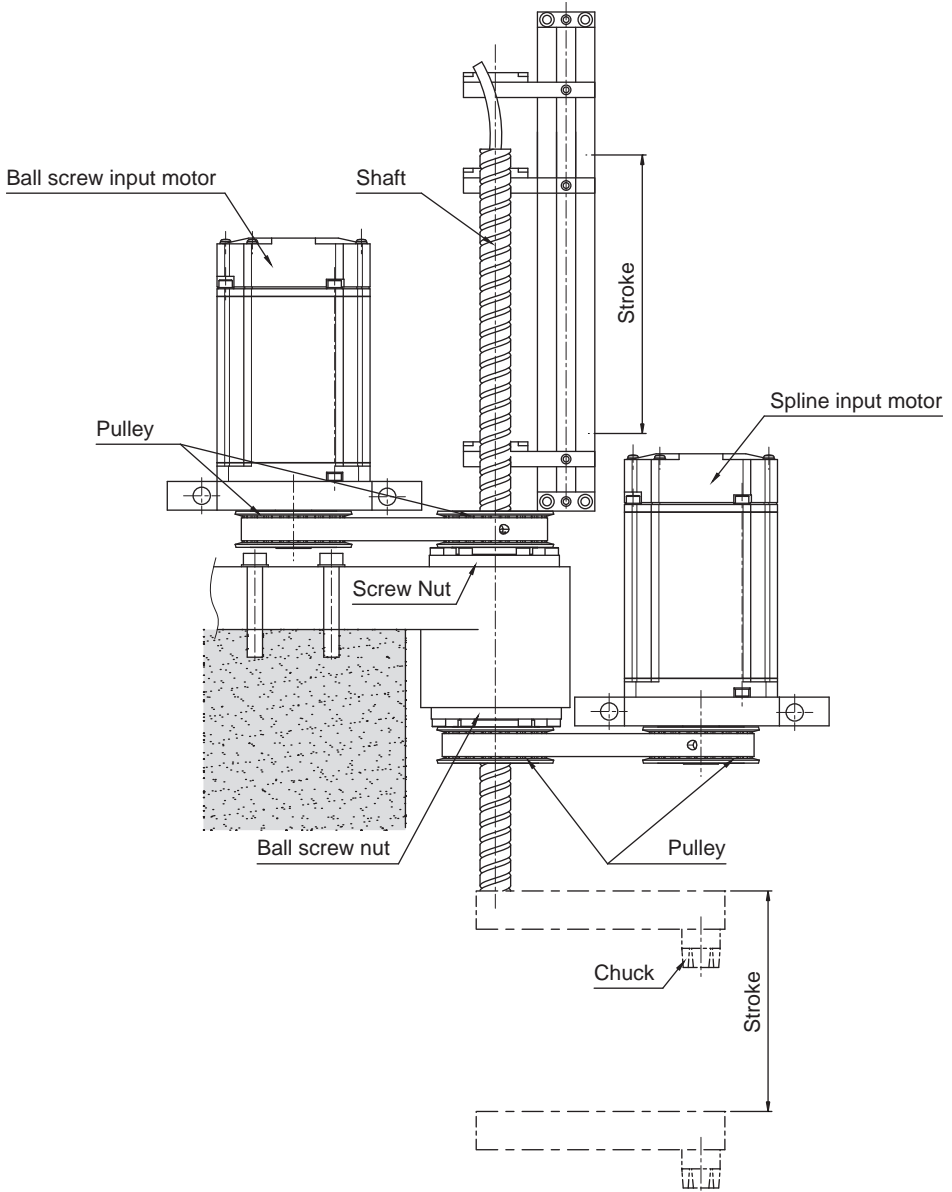

Fig 1.4.1

ABOUT PRECISION ROTARY BALL

1-5 Nominal Model Code of Rotary Series

Nominal Model Code of Rotary Ball Screw

RFSY R 016 16 A2 N G C5 - 500 - P0 (2A)

①
②
③
④
⑤
⑥
⑦
⑧
⑨
⑩
⑪

①	②	③	④
Nominal Model	Threading Direction	Nominal Diameter	Lead
RFSY	R : Right	Unit : mm	Unit : mm
RFBY			
⑤	⑥	⑦	⑧
Number of Turns (Turn-Row)	Flange Type	Product Code	Accuracy Grade
Turn : A : 1.8	N : Round	G : Ground	C0, C1, C2, C3, C5, C7, C10
ex : (1.8×2 = A2)		F : Rolled	
⑨	⑩	⑪	
Overall Length of Shaft	Axial Clearance and Preload Value	Number of Grooves	
Unit : mm	P0, P1, P2, P3, P4	1A : Single start screw	
		2A : Double start screw	

*No symbol required when plating is not needed.

Nominal Model Code of Rotary Ball Spline

RLSF 016 T2 N N H - 500 - P0

①
②
③
④
⑤
⑥
⑦
⑧

①	②	③
Nominal Model	Nominal Diameter	Groove
RLSF	Unit : mm	T2 : 2 Rows
RLBF		T4 : 4 Rows
④	⑤	⑥
Flange Type	Accuracy Grade of Spline Shaft	Spline Shaft Type
N : Round	N : Normal	S : Solid
	H : High	H : Hollow
	P : Precision	
⑦	⑧	
Overall Length of Shaft	Preload Value	
Unit : mm	P0 : No preload	
	P1 : Light preload	
	P2 : Medium preload	

*No symbol required when plating is not needed.

SCREW/SPLINE

Nominal Model Code of Rotary Ball Screw and Ball Spline

RSSY R 016 16 A1 G C5 H H - 500 - P1 (1A)

① ② ③ ④ ⑤ ⑥ ⑦ ⑧ ⑨ ⑩ ⑪ ⑫

① Nominal Model RSSY (RFSY+RLSF) RSLY (RFSY+SLF) RBBY (RFBY+RLBF) RBLY (RFBY+SLF)	② Threading Direction R : Right	③ Nominal Diameter Unit : mm
④ Lead Unit : mm	⑤ Number of Turns (Turn-Row) Turn : A : 1.8 ex : (1.8×1 = A1)	⑥ Product Code G : Ground
⑦ Accuracy Grade of Ball Screw C5	⑧ Accuracy Grade of Spline Shaft H : High	⑨ Spline Shaft Type S : Solid H : Hollow
⑩ Overall Length of Assembly Unit : mm	⑪ Preload Value P1 : Light preload	⑫ Number of Grooves 1A : Single start screw

※ No symbol required when plating is not needed.

D

Rotary Ball Screw/Spline

ABOUT PRECISION ROTARY BALL

1-5 Nominal Model Code of Rotary Series

RFBY Series Specifications

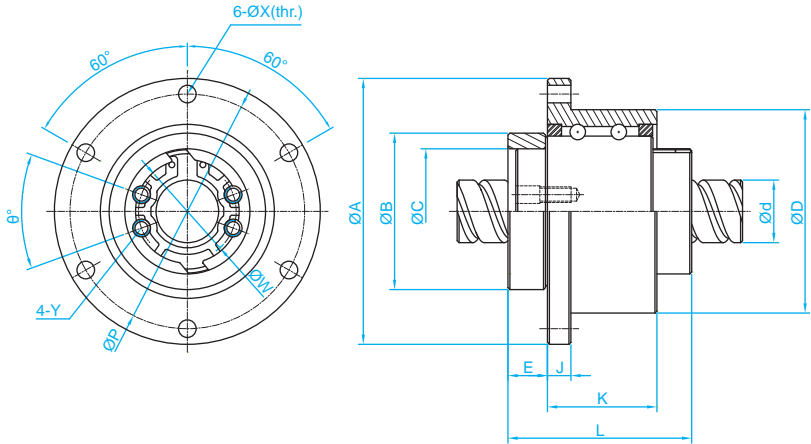

Unit : mm

Model No.	d	I	Da	n	Support Bearing Load Rating		Ball Screw Nut Dimension														Screw Nut Load Rating	
					Ca (kgf)	Coa (kgf)	D	A	B	L	C	E	J	K	P	X	W	Y	θ	Ca (kgf)	Coa (kgf)	
RFBY01616-1.8	16	16	2.778	1.8x1	750	1593	52 ⁰ _{-0.007}	68	40 ⁰ _{-0.025}	47	32 ^{+0.025} ₀	10.1	6	28	60	4.5	25	M4	40	591	1275	
RFBY01616-3.6	16	16	2.778	1.8x2	750	1593	52 ⁰ _{-0.007}	68	40 ⁰ _{-0.025}	47	32 ^{+0.025} ₀	10.1	6	28	60	4.5	25	M4	40	1073	2551	
RFBY02020-1.8	20	20	3.175	1.8x1	1066	2452	62 ⁰ _{-0.007}	78	50 ⁰ _{-0.025}	53.5	39 ^{+0.025} ₀	11	7	34.5	70	4.5	31	M5	40	764	1758	
RFBY02020-3.6	20	20	3.175	1.8x2	1066	2452	62 ⁰ _{-0.007}	78	50 ⁰ _{-0.025}	53.5	39 ^{+0.025} ₀	11	7	34.5	70	4.5	31	M5	40	1387	3515	
RFBY02525-1.8	25	25	3.969	1.8x1	1119	2765	72 ⁰ _{-0.007}	92	58 ⁰ _{-0.03}	65	47 ^{+0.025} ₀	15.8	8	35	81	5.5	38	M6	40	1142	2747	
RFBY02525-3.6	25	25	3.969	1.8x2	1119	2765	72 ⁰ _{-0.007}	92	58 ⁰ _{-0.03}	65	47 ^{+0.025} ₀	15.8	8	35	81	5.5	38	M6	40	2074	5494	
RFBY03232-1.8*	32	32	4.762	1.8x1	2087	5586	80 ⁰ _{-0.007}	105	66 ⁰ _{-0.03}	81	58 ^{+0.03} ₀	21.5	9	42.5	91	6.6	48	M6	40	1664	4345	
RFBY04040-1.8*	40	40	6.35	1.8x1	3183	9306	110 ⁰ _{-0.008}	140	90 ⁰ _{-0.035}	102	73 ^{+0.03} ₀	16.5	11	64.5	123	9	61	M8	50	2662	7031	
RFBY05050-1.8*	50	50	7.938	1.8x1	4328	12573	120 ⁰ _{-0.008}	156	100 ⁰ _{-0.035}	121	90 ^{+0.035} ₀	29	12	70	136	11	75	M10	50	3978	10987	

*Items labeled with ♦ are customized products. For these product orders, please contact TBI in advance.

SCREW/SPLINE

RLBF Series Specifications

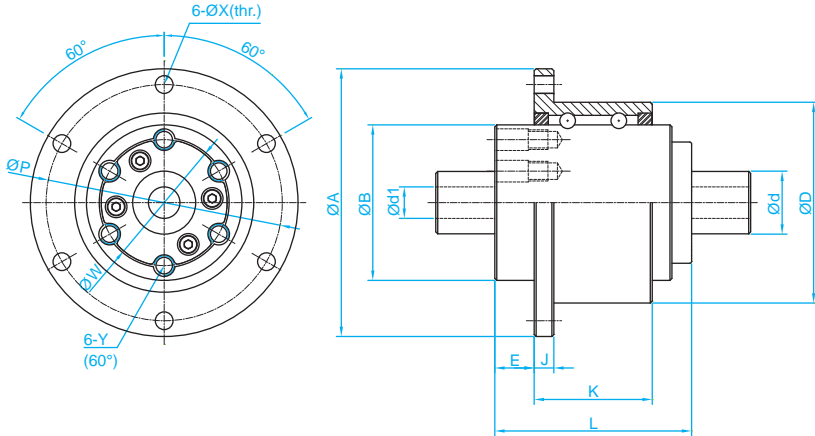

Unit : mm

Model No.	d	d1	Row	Support Bearing Load Rating		Spline Nut Dimension											Ball Spline Load Rating	
				Ca (kgf)	Coa (kgf)	D	A	B	L	E	J	K	P	X	W	Y	Ca (kgf)	Coa (kgf)
RLBF016	16	8	2	746	1597	52 ⁰ _{-0.007}	68	39.5 ⁰ _{-0.025}	50	10	5	30	60	4.5	32	M5	545	849
RLBF020	20	10	2	1011	2138	56 ⁰ _{-0.007}	72	43.5 ⁰ _{-0.025}	63	12	6	42	64	4.5	36	M5	736	1124
RLBF025	25	15	4	1558	4616	62 ⁰ _{-0.007}	78	53 ⁰ _{-0.03}	71	13	6	49	70	4.5	45	M6	1003	1593
RLBF032	32	16	4	2087	5586	80 ⁰ _{-0.007}	105	65.5 ⁰ _{-0.03}	80	17	9	54	91	6.6	55	M6	1324	2251
RLBF040	40	20	4	3141	8705	100 ⁰ _{-0.008}	130	79.5 ⁰ _{-0.03}	100	23	11	63	113	9	68	M6	2972	4033
RLBF050	50	26	4	4317	12585	120 ⁰ _{-0.008}	156	99.5 ⁰ _{-0.035}	125	25	12	87	136	11	85	M10	4086	5615

D

Rotary Ball Screw/Spline

ABOUT PRECISION ROTARY BALL

1-5 Nominal Model Code of Rotary Series

RBBY Series Specifications

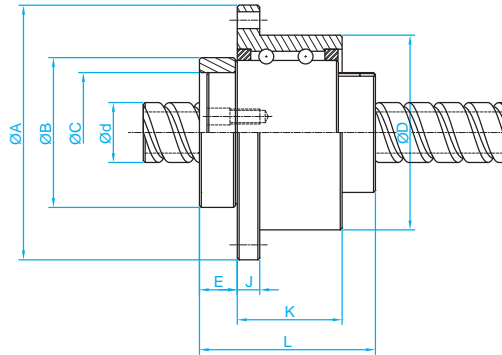
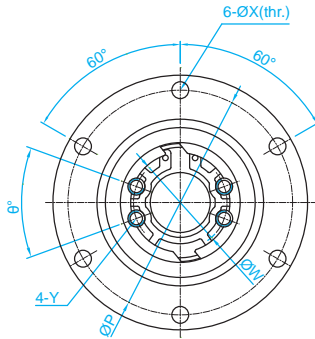

RFBY

Unit : mm

Model No.	d	I	Da	n	Support Bearing Load Rating		Ball Screw Nut Dimension														Screw Nut Load Rating	
					Ca (kgf)	Coa (kgf)	D	A	B	L	C	E	J	K	P	X	W	Y	θ	Ca (kgf)	Coa (kgf)	
RBBY01616-1.8	16	16	2.778	1.8x1	750	1593	52 ⁰ _{-0.007}	68	40 ⁰ _{-0.025}	47	32 ^{+0.025} ₀	10.1	6	28	60	4.5	25	M4	40	591	1275	
RBBY02020-1.8	20	20	3.175	1.8x1	1066	2452	62 ⁰ _{-0.007}	78	50 ⁰ _{-0.025}	53.5	39 ^{+0.025} ₀	11	7	34.5	70	4.5	31	M5	40	764	1758	
RBBY02525-1.8	25	25	3.969	1.8x1	1119	2765	72 ⁰ _{-0.007}	92	58 ⁰ _{-0.03}	65	47 ^{+0.025} ₀	15.8	8	35	81	5.5	38	M6	40	1142	2747	
RBBY03232-1.8*	32	32	4.762	1.8x1	2087	5586	80 ⁰ _{-0.007}	105	66 ⁰ _{-0.03}	81	58 ^{+0.03} ₀	21.5	9	42.5	91	6.6	48	M6	40	1664	4345	
RBBY04040-1.8*	40	40	6.35	1.8x1	3183	9306	110 ⁰ _{-0.008}	140	90 ⁰ _{-0.035}	102	73 ^{+0.03} ₀	16.5	11	64.5	123	9	61	M8	50	2662	7031	
RBBY05050-1.8*	50	50	7.938	1.8x1	4328	12573	120 ⁰ _{-0.008}	156	100 ⁰ _{-0.035}	121	90 ^{+0.035} ₀	29	12	70	136	11	75	M10	50	3978	10987	

※ Items labeled with ♦ are customized products. For these product orders, please contact TBI in advance.

D

Rotary Ball Screw/Spline

SCREW/SPLINE

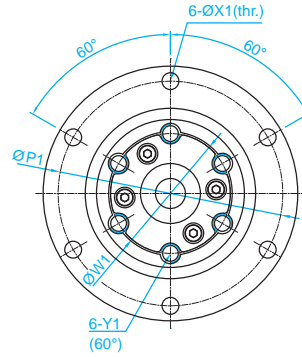
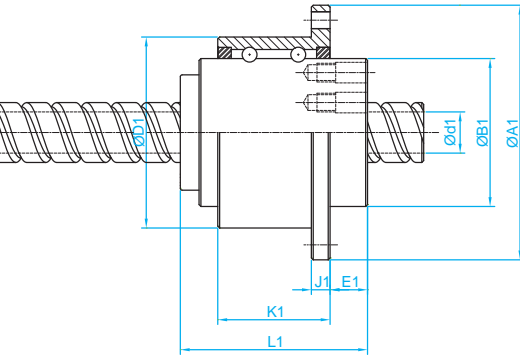

RLBF

Unit : mm

Model No.	d	d1	Row	Support Bearing Load Rating		Spline Nut Dimension											Ball Spline Load Rating	
				Ca (kgf)	Coa (kgf)	D1	A1	B1	L1	E1	J1	K1	P1	X1	W1	Y1	Ca (kgf)	Coa (kgf)
RBBY01616	16	11	2	746	1597	52 ⁰ _{-0.007}	68	39.5 ⁰ _{-0.025}	50	10	5	30	60	4.5	32	M5	545	849
RBBY02020	20	14	2	1011	2138	56 ⁰ _{-0.007}	72	43.5 ⁰ _{-0.025}	63	12	6	42	64	4.5	36	M5	736	1124
RBBY02525	25	18	4	1558	4616	62 ⁰ _{-0.007}	78	53 ⁰ _{-0.03}	71	13	6	49	70	4.5	45	M6	1003	1593
RBBY03232	32	23	4	2087	5586	80 ⁰ _{-0.007}	105	65.5 ⁰ _{-0.03}	80	17	9	54	91	6.6	55	M6	1324	2251
RBBY04040	40	29	4	3141	8705	100 ⁰ _{-0.008}	130	79.5 ⁰ _{-0.03}	100	23	11	63	113	9	68	M6	2972	4033
RBBY05050	50	36	4	4317	12585	120 ⁰ _{-0.008}	156	99.5 ⁰ _{-0.035}	125	25	12	87	136	11	85	M10	4086	5615

D

Rotary Ball Screw/Spline

ABOUT PRECISION ROTARY BALL

1-5 Nominal Model Code of Rotary Series

RBLY Series Specifications

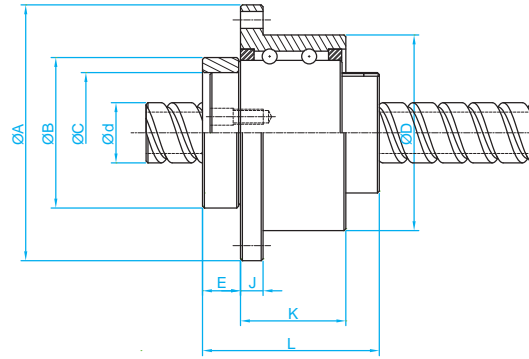
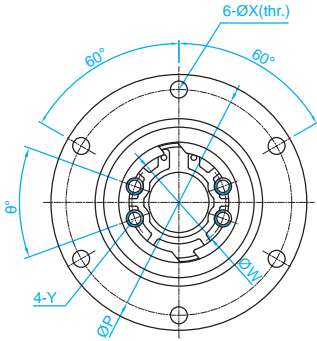

RFBY

Unit : mm

Model No.	d	I	Da	n	Support Bearing Load Rating		Ball Screw Nut Dimension													Screw Nut Load Rating	
					Ca (kgf)	Coa (kgf)	D	A	B	L	C	E	J	K	P	X	W	Y	θ	Ca (kgf)	Coa (kgf)
RBLY01616-1.8	16	16	2.778	1.8x1	750	1593	52 ⁰ _{-0.007}	68	40 ⁰ _{-0.025}	47	32 ^{+0.025} ₀	10.1	6	28	60	4.5	25	M4	40	591	1275
RBLY02020-1.8	20	20	3.175	1.8x1	1066	2452	62 ⁰ _{-0.007}	78	50 ⁰ _{-0.025}	53.5	39 ^{+0.025} ₀	11	7	34.5	70	4.5	31	M5	40	764	1758
RBLY02525-1.8	25	25	3.969	1.8x1	1119	2765	72 ⁰ _{-0.007}	92	58 ⁰ _{-0.03}	65	47 ^{+0.025} ₀	15.8	8	35	81	5.5	38	M6	40	1142	2747
RBLY03232-1.8♦	32	32	4.762	1.8x1	2087	5586	80 ⁰ _{-0.007}	105	66 ⁰ _{-0.03}	81	58 ^{+0.03} ₀	21.5	9	42.5	91	6.6	48	M6	40	1664	4345
RBLY04040-1.8♦	40	40	6.35	1.8x1	3183	9306	110 ⁰ _{-0.008}	140	90 ⁰ _{-0.035}	102	73 ^{+0.03} ₀	16.5	11	64.5	123	9	61	M8	50	2662	7031
RBLY05050-1.8♦	50	50	7.938	1.8x1	4328	12573	120 ⁰ _{-0.008}	156	100 ⁰ _{-0.035}	121	90 ^{+0.035} ₀	29	12	70	136	11	75	M10	50	3978	10987

※Items labeled with ♦ are customized products. For these product orders, please contact TBI in advance.

SCREW/SPLINE

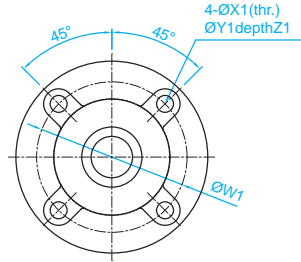
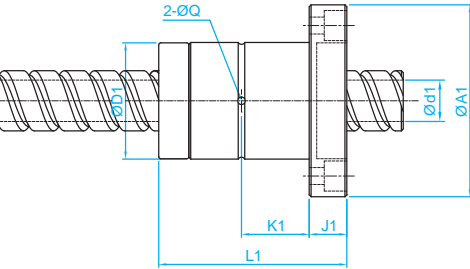

SLF

Unit : mm

Model No.	d	d1	Row	Spline Nut Dimension										Ball Spline Load Rating	
				D1	A1	L1	J1	K1	W1	X1	Y1	Z1	Q	Ca (kgf)	Coa (kgf)
RBLY01616	16	11	2	31 ⁰ _{-0.016}	51	50	10	18	40	4.5	8	6	2	545	849
RBLY02020	20	14	2	35 ⁰ _{-0.016}	58	56	10	18	45	5.5	9.5	5.4	2	724	1109
RBLY02525	25	18	4	42 ⁰ _{-0.016}	65	71	13	26.5	52	5.5	9.5	8	3	1003	1593
RBLY03232	32	23	4	49 ⁰ _{-0.016}	77	80	13	30	62	6.6	11	6.5	3	1324	2251
RBLY04040	40	29	4	64 ⁰ _{-0.019}	100	100	18	36	82	9	14	12	4	2972	4033
RBLY05050	50	36	4	80 ⁰ _{-0.019}	124	125	20	46.5	102	11	17.5	12	4	4086	5615

D

Rotary Ball Screw/Spline

ABOUT PRECISION ROTARY BALL

1-5 Nominal Model Code of Rotary Series

RFSY Series Specifications

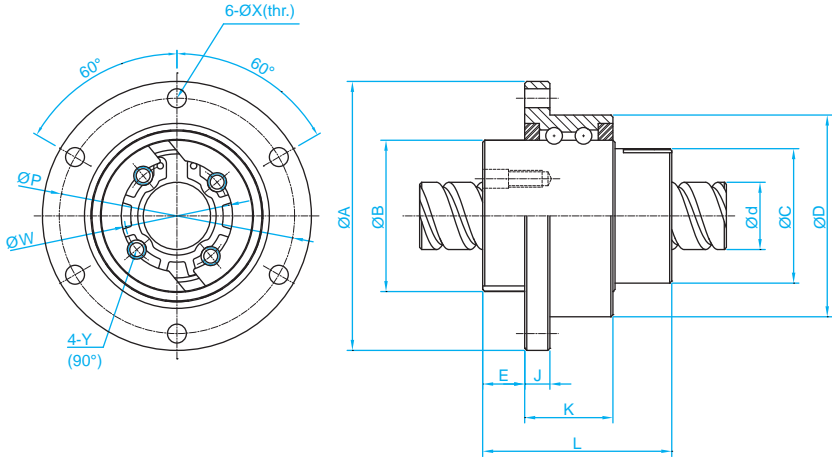

Unit : mm

Model No.	d	I	Da	n	Support Bearing Load Rating		Ball Screw Nut Dimension													Screw Nut Load Rating	
					Ca (kgf)	Coa (kgf)	D	A	B	L	C	E	J	K	P	X	W	Y	Ca (kgf)	Coa (kgf)	
RFSY01616-1.8	16	16	2.778	1.8x1	730	1484	48 ^{-0.009} _{-0.025}	64	36 ⁰ _{-0.025}	45	32	10	6	21	56	4.5	25	M4	591	1275	
RFSY01616-3.6	16	16	2.778	1.8x2	730	1484	48 ^{-0.009} _{-0.025}	64	36 ⁰ _{-0.025}	45	32	10	6	21	56	4.5	25	M4	1073	2551	
RFSY02020-1.8	20	20	3.175	1.8x1	788	1811	56 ^{0.01} _{-0.029}	72	43.5 ⁰ _{-0.025}	52	39	11	6	21	64	4.5	31	M5	764	1758	
RFSY02020-3.6	20	20	3.175	1.8x2	788	1811	56 ^{0.01} _{-0.029}	72	43.5 ⁰ _{-0.025}	52	39	11	6	21	64	4.5	31	M5	1387	3515	
RFSY02525-1.8	25	25	3.969	1.8x1	1094	2607	66 ^{0.01} _{-0.029}	86	52 ⁰ _{-0.03}	64	47	13	7	25	75	5.5	38	M6	1142	2747	
RFSY02525-3.6	25	25	3.969	1.8x2	1094	2607	66 ^{0.01} _{-0.029}	86	52 ⁰ _{-0.03}	64	47	13	7	25	75	5.5	38	M6	2074	5494	
RFSY03232-1.8*	32	32	4.762	1.8x1	1191	3233	78 ^{0.01} _{-0.029}	103	63 ⁰ _{-0.03}	78	58	14	8	25	89	6.6	48	M6	1664	4345	
RFSY04040-1.8*	40	40	6.35	1.8x1	2216	6685	100 ^{0.012} _{-0.034}	130	79.5 ⁰ _{-0.035}	99	73	16.5	10	33	113	9	61	M8	2662	7031	

* Items labeled with ♦ are customized products. For these product orders, please contact TBI in advance.

SCREW/SPLINE

RLSF Series Specifications

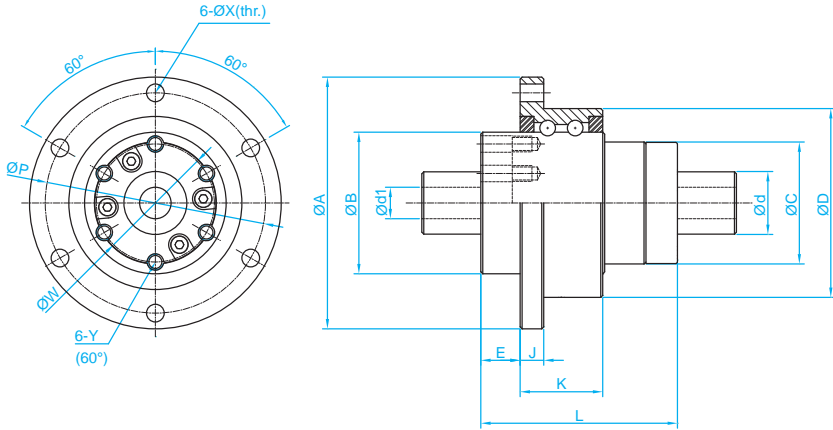

Unit : mm

Model No.	d	d1	Row	Support Bearing Load Rating		Spline Nut Dimension														Ball Spline Load Rating	
				Ca (kgf)	Coa (kgf)	D	A	B	L	C	E	J	K	P	X	W	Y	Ca (kgf)	Coa (kgf)		
RLSF016	16	8	2	730	1484	48 ^{-0.009} _{-0.025}	64	36 ⁰ _{-0.025}	50	31	10	6	21	56	4.5	30	M4	545	849		
RLSF020	20	10	2	788	1811	56 ^{-0.01} _{-0.029}	72	43.5 ⁰ _{-0.025}	63	35	12	6	21	64	4.5	36	M5	736	1124		
RLSF025	25	15	4	1094	2607	66 ^{-0.01} _{-0.029}	86	52 ⁰ _{-0.03}	71	42	13	7	25	75	5.5	44	M5	1003	1593		
RLSF032	32	16	4	1191	3233	78 ^{-0.01} _{-0.029}	63	62 ⁰ _{-0.03}	80	52	17	8	25	89	6.6	54	M6	1324	2251		
RLSF040	40	20	4	2216	6685	100 ^{-0.012} _{-0.034}	130	79.5 ⁰ _{-0.035}	100	64	20	10	33	113	9	68	M6	2972	4033		

D

Rotary Ball Screw/Spline

ABOUT PRECISION ROTARY BALL

1-5 Nominal Model Code of Rotary Series

RSSY series specifications

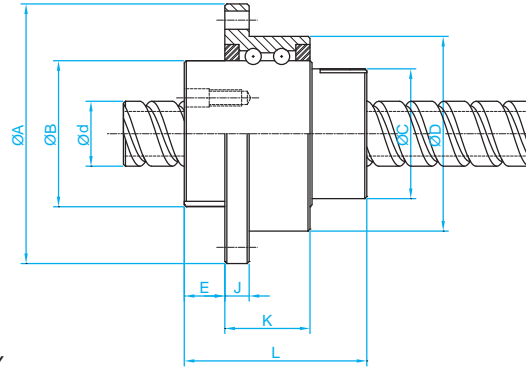
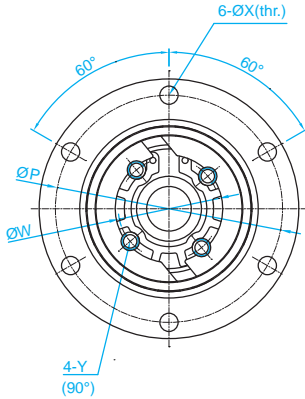

RFSY

Unit : mm

Model No.	d	I	Da	n	Support Bearing Load Rating		Ball Screw Nut Dimension													Screw Nut Load Rating	
					Ca (kgf)	Coa (kgf)	D	A	B	L	C	E	J	K	P	X	W	Y	Ca (kgf)	Coa (kgf)	
RSSY01616-1.8	16	16	2.778	1.8x1	730	1484	48 ^{-0.009} _{-0.025}	64	36 ⁰ _{-0.025}	45	32	10	6	21	56	4.5	25	M4	591	1275	
RSSY02020-1.8	20	20	3.175	1.8x1	788	1811	56 ^{0.01} _{-0.029}	72	43.5 ⁰ _{-0.025}	52	39	11	6	21	64	4.5	31	M5	764	1758	
RSSY02525-1.8	25	25	3.969	1.8x1	1094	2607	66 ^{0.01} _{-0.029}	86	52 ⁰ _{-0.03}	64	47	13	7	25	75	5.5	38	M6	1142	2747	
RSSY03232-1.8♦	32	32	4.762	1.8x1	1191	3233	78 ^{0.01} _{-0.029}	103	63 ⁰ _{-0.03}	78	58	14	8	25	89	6.6	48	M6	1664	4345	
RSSY04040-1.8♦	40	40	6.35	1.8x1	2216	6685	110 ^{0.012} _{-0.034}	130	79.5 ⁰ _{-0.035}	99	73	16.5	10	33	113	9	61	M8	2662	7031	

※ Items labeled with ♦ are customized products. For these product orders, please contact TBI in advance.

SCREW/SPLINE

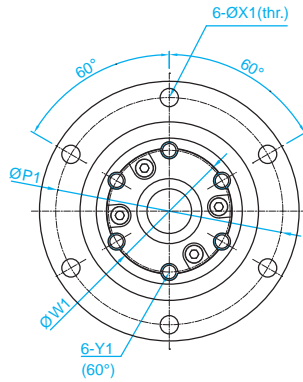
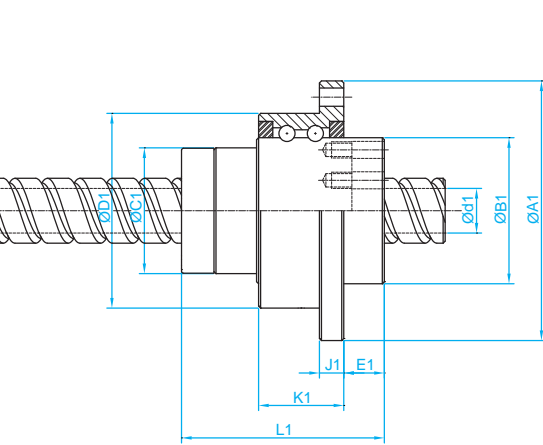

RLSF

Unit : mm

Model No.	d	d1	Row	Support Bearing Load Rating		Spline Nut Dimension													Ball Spline Load Rating	
				Ca (kgf)	Coa (kgf)	D1	A1	B1	L1	C1	E1	J1	K1	P1	X1	W1	Y1	Ca (kgf)	Coa (kgf)	
RSSY01616	16	11	2	730	1484	48 ^{-0.009} _{-0.025}	64	36 ⁰ _{-0.025}	50	31	10	6	21	56	4.5	30	M4	545	849	
RSSY02020	20	14	2	788	1811	56 ^{-0.01} _{-0.029}	72	43.5 ⁰ _{-0.025}	63	35	12	6	21	64	4.5	36	M5	736	1124	
RSSY02525	25	18	4	1094	2607	66 ^{-0.01} _{-0.029}	86	52 ⁰ _{-0.03}	71	42	13	7	25	75	5.5	44	M5	1003	1593	
RSSY03232	32	23	4	1191	3233	78 ^{-0.01} _{-0.029}	103	63 ⁰ _{-0.03}	80	52	17	8	25	89	6.6	54	M6	1324	2251	
RSSY04040	40	29	4	2216	6685	100 ^{-0.012} _{-0.034}	130	79.5 ⁰ _{-0.035}	100	64	20	10	33	113	9	68	M6	2972	4033	

D

Rotary Ball Screw/Spline

ABOUT PRECISION ROTARY BALL

1-5 Nominal Model Code of Rotary Series

RSLY Series Specifications

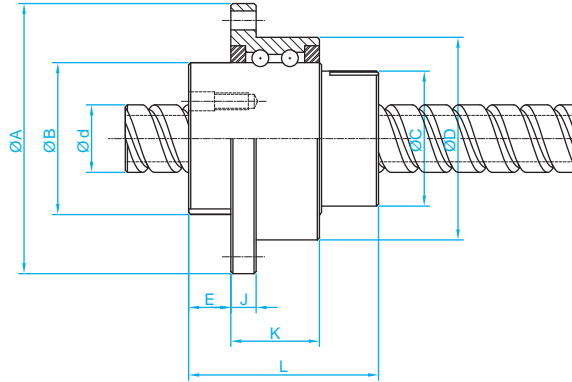
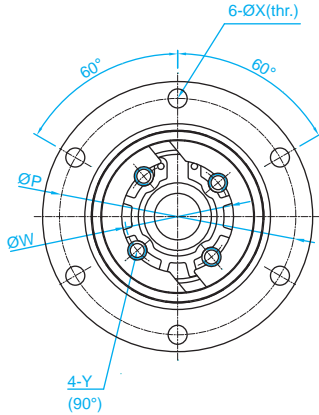

Unit : mm

Model No.	d	I	Da	n	Support Bearing Load Rating		Ball Screw Nut Dimension													Screw Nut Load Rating	
					Ca (kgf)	Coa (kgf)	D	A	B	L	C	E	J	K	P	X	W	Y	Ca (kgf)	Coa (kgf)	
RSLY01616-1.8	16	16	2.778	1.8x1	730	1484	48 ^{-0.009} _{-0.025}	64	36 ⁰ _{-0.025}	45	32	10	6	21	56	4.5	25	M4	591	1275	
RSLY02020-1.8	20	20	3.175	1.8x1	788	1811	56 ^{-0.01} _{-0.029}	72	43.5 ⁰ _{-0.025}	52	39	11	6	21	64	4.5	31	M5	764	1758	
RSLY02525-1.8	25	25	3.969	1.8x1	1094	2607	66 ^{-0.01} _{-0.029}	86	52 ⁰ _{-0.03}	64	47	13	7	25	75	5.5	38	M6	1142	2747	
RSLY03232-1.8 [◆]	32	32	4.762	1.8x1	1191	3233	78 ^{-0.01} _{-0.029}	103	63 ⁰ _{-0.03}	78	58	14	8	25	89	6.6	48	M6	1664	4345	
RSLY04040-1.8 [◆]	40	40	6.35	1.8x1	2216	6685	100 ^{-0.012} _{-0.034}	130	79.5 ⁰ _{-0.035}	99	73	16.5	10	33	113	9	61	M8	2662	7031	

※ Items labeled with ◆ are customized products. For these product orders, please contact TBI in advance.

SCREW/SPLINE

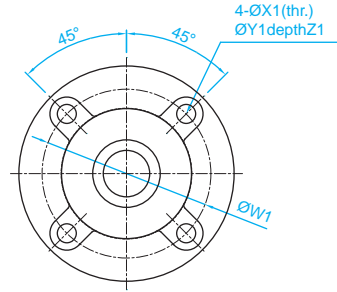
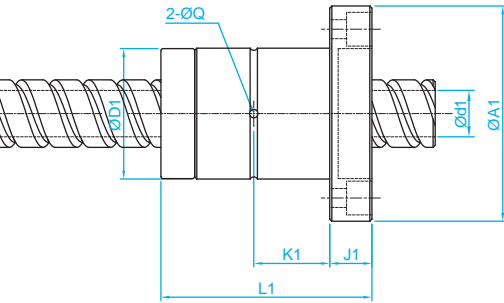

Unit : mm

Model No.	d	d1	Row	Spline Nut Dimension										Ball Spline Load Rating	
				D1	A1	L1	J1	K1	W1	X1	Y1	Z1	Q	Ca (kgf)	Coa (kgf)
RSLY01616	16	11	2	$31^{0}_{-0.016}$	51	50	10	18	40	4.5	8	6	2	545	849
RSLY02020	20	14	2	$35^{0}_{-0.016}$	58	56	10	18	45	5.5	9.5	5.4	2	724	1109
RSLY02525	25	18	4	$42^{0}_{-0.016}$	65	71	13	26.5	52	5.5	9.5	8	3	1003	1593
RSLY03232	32	23	4	$49^{0}_{-0.016}$	77	80	13	30	62	6.6	11	6.5	3	1324	2251
RSLY04040	40	29	4	$64^{0}_{-0.019}$	100	100	18	36	82	9	14	12	4	2972	4033

D

Rotary Ball Screw/Spline

Single Axis Actuator



1-1 Structure and Features of TBI MOTION Actuator	E02
1-1-1 Basic Structure of TBI MOTION Actuator.....	E02
1-2 Features of the Single Axis Actuator	E03
1-2-1 Advantages of Modularized Design	E03
1-2-2 Loads from all Directions	E03
1-2-3 High Rigidity.....	E03
1-2-4 High Accuracy, Saving Space	E03
1-3 Purchase of Peripherals	E04
1-3-1 About the Single Axis Actuator.....	E04
1-3-2 KP Series Nominal Model Codes.....	E06
1-4 Accuracy Design	E08
1-4-1 Accuracy Level.....	E08
1-5 Maximum Speed	E09
1-5-1 Maximum Length and Maximum Moving Speed.....	E09
1-6 Calculation of Service Life	E10
1-6-1 Static Safety Factor	E10
1-6-2 Service Life.....	E11
1-7 Lubrication	E13
1-7-1 Notice on Lubrication.....	E13
1-8 KP Product Series	E14
KP26 (Standard Type).....	E14
KP26(Standard Type with Protective Cap).....	E15
KP26(Low-Assembly)	E16
KP33(Standard Type)	E17
KP33(Standard Type with Protective Cap).....	E18
KP33(Low-Assembly).....	E19
KP33(Light-Load Type)	E20
KP33(Light-Load Type with Protective Cap).....	E21
KP33(Light-Load Type, Low-Assembly).....	E22
KP46(Standard Type)	E23
KP46(Standard Type with Protective Cap).....	E24
KP46(Low-Assembly).....	E25
KP46(Light-Load Type)	E26
KP46(Light-Load Type with Protective Cap).....	E27
KP46(Light-Load Type, Low-Assembly).....	E28
1-9 The Adapting Flange of the Motor Base and the Motor	E29
1-9-1 List of Suitable Motors.....	E29
1-9-2 The Adapting Flange of the Motor Base and the Motor.....	E33
1-9-3 Sensor.....	E38
1-9-4 Sensor Track	E39

ABOUT SINGLE AXIS ACTUATOR

1-1 Structure and Features of *TBI MOTION* Actuator

■ 1-1-1 Basic Structure of *TBI MOTION* Actuator

Adopts the advantages of the TBI Motion linear guides and screws then designs the nut and block into an integral mechanism. With the highly rigid U-Rail track optimized section, it minimize the required space and the time for assembly. This ensures its demand for high rigidity and high accuracy. The ball rolling face adopts an excellent design of a 2-row Gothic arc and 45° contact angle. Moreover, the design allows the X-axis and Y-axis to bear loads from all directions.

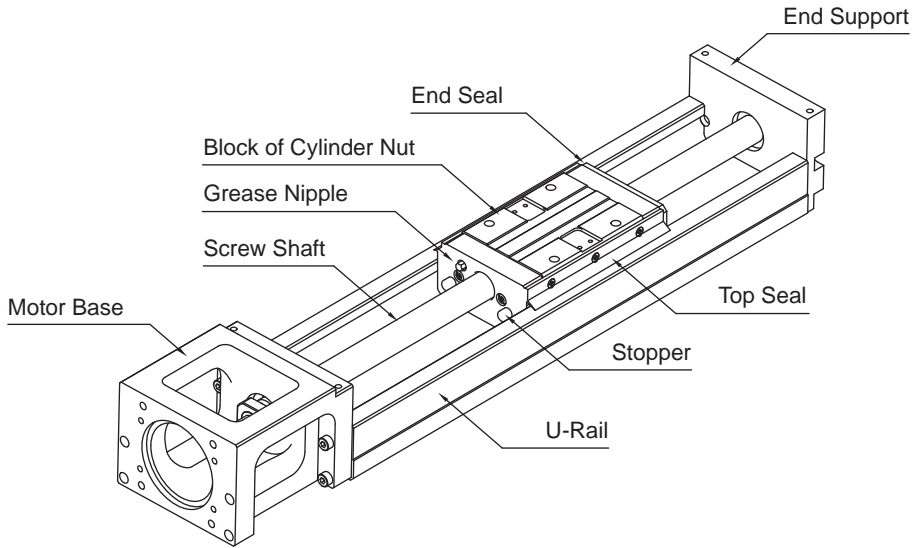

Fig 1.1.1 Structure of the Single Axis Actuator body

1-2 Features of the Single Axis Actuator

1-2-1 Advantages of Modularized Design

The combination of ball screw and linear guide makes simple installation possible, shorten replacement time and prolong service life. The traditional linear platform device requires guides and drive elements. It features easy-assembly, high rigidity, small size, etc. Moreover it saves more time and space for clients.

1-2-2 Loads from all Directions

The contact surface of ball and groove is designed to be 45° and can bear the same rated load of any type of installation, radially, reverse-radially or laterally.

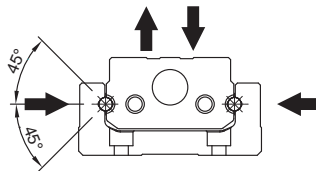

Fig 1.2.1

1-2-3 High Rigidity

The Ansys optimized U-Rail track design allows the track to be light weight and accomplish higher rigidity at cantilever load to achieve a perfect balance between rigidity and volume.

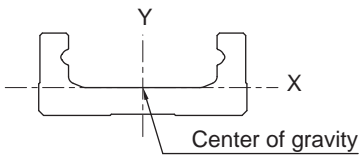

Fig 1.2.2

Table 1.1.1

Unit : mm⁴

Model	I _x	I _y
KP26	1.116x10 ⁴	1.393x10 ⁵
KP33	3.542x10 ⁴	3.243x10 ⁵
KP46	1.256x10 ⁵	1.305x10 ⁶

(Note) I_x : 2nd moment revolves of area around the X axis ;
I_y : 2nd moment revolves of area around the Y axis.

1-2-4 High Accuracy, Saving Space

The variable loading minimizes the friction to meet a high accuracy demand. A combination of the nut with the slide makes space saving and an optimized allocation possible.

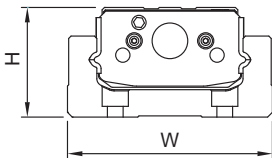

Fig 1.2.3

Table 1.1.2

Unit : mm

Model	H	W
KP26	26	50
KP33	33	60
KP46	46	86

ABOUT SINGLE AXIS ACTUATOR

1-3 Purchase of Peripherals

■ 1-3-1 About the Single Axis Actuator

To satisfy various industrial operations, the KP Single Axis Actuator can additionally purchase a dust cap, a dust expansion sleeve, a sensor, a motor adapting flange, etc.

- Dust Cap & Dust Expansion Sleeve : prevent foreign objects from entering and ensure the overall accuracy, service life and smoothness.
- Motor Adapting Flange : fit for different motors and secured on the Single Axis Actuator.
- Sensor : a safety protection device which assists with slide positioning, original start up and traveling.

Components and Accessories of the Single Axis Actuator

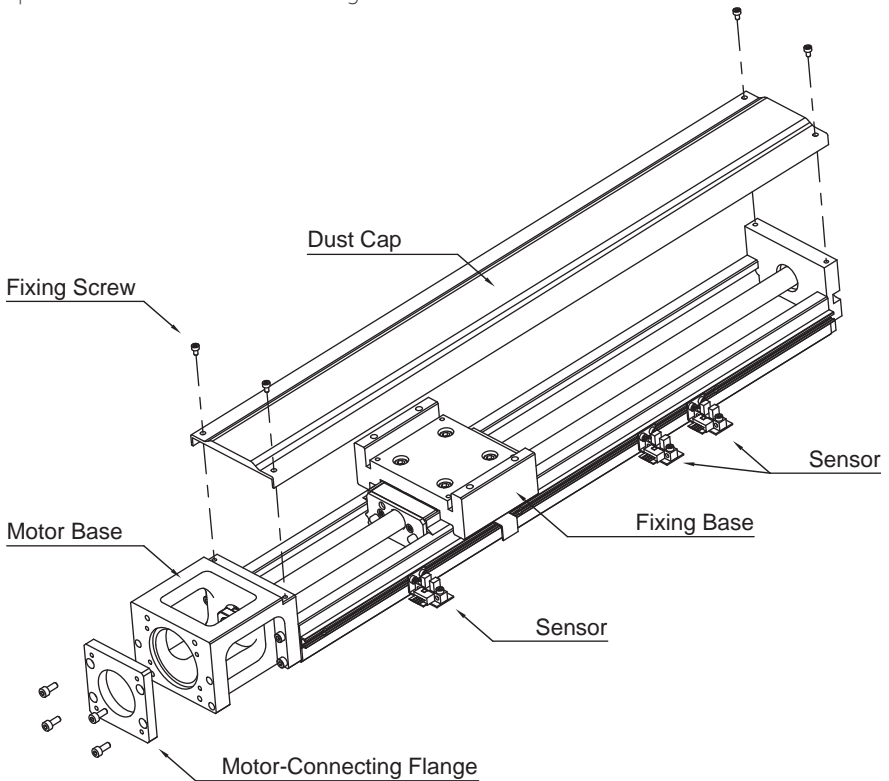

Fig 1.3.1 Components and Accessories

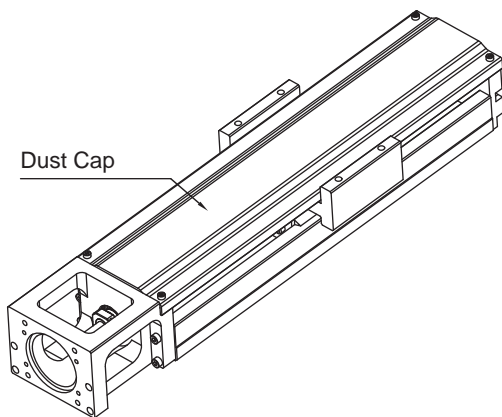

Fig 1.3.2 Dust Cap

ABOUT SINGLE AXIS ACTUATOR

1-3 Purchase of Peripherals

■ 1-3-2 KP Series Nominal Model Codes

KP 026 02 K N - 2 - 300 - P + M01 F01 C01 S01

① ② ③ ④ ⑤ ⑥ ⑦ ⑧ ⑨ ⑩ ⑪ ⑫

①	②	③	④
Nominal Model	Size	Ball Screw Travel	Nut Type
KP	26, 33, 46	KP26 : 2 KP33 : 5, 10 KP46 : 10, 20	K, V : Standard X : Special (K No. 26, V Nos. 33 & 46)

⑤	⑥	⑦	⑧
Carriage Length	No. of Slides	Track Length	Accuracy Level
N : Standard S : Light Load	1, 2	Unit : mm	P : Ground H : High N : Rolled

⑨	⑩	⑪
Motor	Motor Adapting Flange	Dust Cap
□ : None M : Motor (ref. E29~32)	(ref. E33~37)	□ : None C01 : Dust Cap C02 : Dust Expansion Sleeve

⑫
Include Sensor
□ : Standard no Sensor
S01~03 : Only Sensor (ref. E38, Table 1.9.6)
S04~06 : Omron SX671
S07~09 : Omron SX674
S10~12 : SUNX GX-F12A
S13~15 : SUNX GX-F12A-P

※ When choosing the Single Axis Actuator, each set has 3 set of sensors included. Please consult **TBI MOTION** for special requirements.



Single Axis Actuator

KP Load Specs

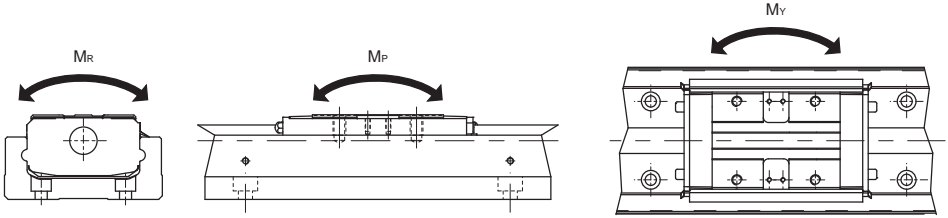

Model No.		Ball Screw				Linear Guide															
		d	I	Ca (kgf)	Coa (kgf)	Ca (kgf)		Coa (kgf)		Static Permissible Moment											
						N	S	N	S	MP(N-m)				MY(N-m)				MR(N-m)			
										LS	LD	NS	ND	LS	LD	NS	ND	LS	LD	NS	ND
KP2602	Ground	8	2	1829	3590	8058	-	10578	-	62	481	-	-	62	481	-	-	180	360	-	-
	High			1829	3590																
	Rolled			1555	3051																
KP3305	Ground	12	5	3996	7249	11201	8441	14839	9893	108	720	49	413	108	720	49	413	310	620	207	413
	High			3996	7249																
	Rolled			3396	6161																
KP3310	Ground	12	10	2696	4592	11201	8441	14839	9893	108	720	49	413	108	720	49	413	310	620	207	413
	High			2696	4592																
	Rolled			2292	3903																
KP4610	Ground	15	10	5876	11131	39886	33246	56974	44313	610	4021	307	2517	610	4021	307	2517	1728	3456	1344	2688
	High			5876	11131																
	Rolled			-	-																
KP4620	Ground	15	20	3790	7033	39886	33246	56974	44313	610	4021	307	2517	610	4021	307	2517	1728	3456	1344	2688
	High			3790	7033																
	Rolled			-	-																



Single Axis Actuator

ABOUT SINGLE AXIS ACTUATOR

1-4 Accuracy Design

■ 1-4-1 Accuracy Level

The accuracy of the Single Axis Actuator is split into Ground (P), High (H) and Rolled (N), as shown below.

Table 1.4.1

Unit : mm

Model	Track Length	Positioning Repeatability			Positioning Accuracy			Positioning Parallelism			Max. Starting Torque (N-cm)			
		Ground	High	Rolled	Ground	High	Rolled	Ground	High	Rolled	Ground	High	Rolled	
KP26	150	±0.003	±0.005	±0.01	0.020	0.060	-	0.010	0.025	-	4	2	2	
	200													
	250													
	300													
KP33	150	±0.003	±0.005	±0.01	0.020	0.060	-	0.010	0.025	-	15	7	7	
	200													
	300													
	400													
	500	±0.003	±0.005	±0.01	0.025	0.100	-	0.015	0.035	-				
	600													
KP46	340	±0.003	±0.005	-	0.025	0.100	-	0.015	0.035	-	15	10	-	
	440													
	540													
	640													
	740	±0.003	±0.005	-	0.030	0.120	-	0.020	0.040	-				17
	940	±0.003	±0.005	-	0.040	0.150	-	0.030	0.050	-				25



Single Axis Actuator

1-5 Maximum Speed

■ 1-5-1 Maximum Length and Maximum Moving Speed

Restricted by the critical speed and DN value of the screw, the Single Axis Robot's max. moving speed is shown below.

Table 1.4.1

Model	Ball Screw Lead (mm)	Ball Screw Lead (mm)	Speed (mm/sec)		
			Ground	High	Rolled
KP26	02	150	270	270	270
		200	270	270	270
		250	270	270	270
		300	270	270	270
KP33	05	150	550	550	390
		200	550	550	390
		300	550	550	390
		400	550	550	390
		500	550	550	390
		600	340	340	340
	10	150	1100	1100	790
		200	1100	1100	790
		300	1100	1100	790
		400	1100	1100	790
		500	1100	1100	790
		600	670	670	670
KP46	10	340	740	740	520
		440	740	740	520
		540	740	740	520
		640	740	740	520
		740	740	740	520
		940	610	610	430
	20	340	1480	1480	1050
		440	1480	1480	1050
		540	1480	1480	1050
		640	1480	1480	1050
		740	1480	1480	1050
		940	1220	1220	870

ABOUT SINGLE AXIS ACTUATOR

1-6 Calculation of Service Life

■ 1-6-1 Static Safety Factor

1. Analyze the Track :

When calculating the load of a track, first we must assess the average load required for the service life, as well as the maximum load required at a static rating. In particular, a travel distance is too short may cause a big moment due to cantilever load, leading to an excessive load.

$$f_s = \frac{C_o}{P_{\max}}$$

f_s : Static safety factor

C_o : Basic static load rating (N)

P_{\max} : Max. load (N)

2. Analyze the Support End of the Ball Screw : Single Axis Actuator takes extra axial force due to the inertia force caused by start-stop therefore the static safety factor of Single Axis Actuator must be considered.

$$f_s = \frac{C_{oa}}{F_{\max}}$$

f_s : Static safety factor

C_{oa} : Basic static load rating (N)

F_{\max} : Max. load (N)

Table 1.6.1 Static Safety Factor f_s

Machines that use the linear motion system	Load conditions	Lower limit of f_s
Integrated industrial machines	No vibration & impact	1.0 - 3.5
	With vibration & impact	2.0 - 5.0

※The reference value of the static safety factor may defer depending on the environment, the lubrication, the accuracy or rigidity of installation.

【 f_c : Contact Factor】

With KP-LD, 2 internal slides are used close to each other, the contact factor multiplied by the basic static load rating is 0.81 . Please refer to A10. Table 1.3.2 (when used closely, the number of slides is 1 or 2).

【 f_w : Load Factor】

Please refer to A10. Table 1.3.3.

When Single Axis Actuator operating with load, the load distribution on the track becomes uneven and partial loads get heavier as well. At this point, multiply the moment factor that equivalent to the moment value in Table 1.6.2 for load calculating.

Model	Equivalentfactor $K_a(\text{mm}^{-1})$	Equivalentfactor $K_b(\text{mm}^{-1})$	Equivalentfactor $K_c(\text{mm}^{-1})$
KP26-N-LS	1.70×10^{-1}	1.70×10^{-1}	5.88×10^{-2}
KP26-N-LD	2.19×10^{-2}	2.19×10^{-2}	5.88×10^{-2}
KP33-S-NS	1.37×10^{-1}	1.37×10^{-1}	4.79×10^{-2}
KP33-S-ND	2.06×10^{-2}	2.06×10^{-2}	4.79×10^{-2}
KP33-N-LS	2.0×10^{-1}	2.0×10^{-1}	4.79×10^{-2}
KP33-N-LD	2.39×10^{-2}	2.39×10^{-2}	4.79×10^{-2}
KP46-S-NS	1.44×10^{-1}	1.44×10^{-1}	3.29×10^{-2}
KP46-S-ND	1.76×10^{-2}	1.76×10^{-2}	3.29×10^{-2}
KP46-N-LS	9.33×10^{-2}	9.33×10^{-2}	3.29×10^{-2}
KP46-N-LD	1.41×10^{-2}	1.41×10^{-2}	3.29×10^{-2}

K_a : Moment equivalent coefficient of trimming.

K_b : Moment equivalent coefficient of shifting.

K_c : Moment equivalent coefficient of rolling.

■ 1-6-2 Service Life

KP is constituted by a track, a ball screw and supporting bearings. The life of each component part can be calculated as follows :

1. Analyze the track :

Rating Life

$$L = \left(\frac{f_c \times C}{f_w \times P_c} \right)^3 \cdot 50 \text{ km}$$

L : Rated Life (km)

C : Basic Dynamic Rated Load (N)

P_c : Value of the Calculated Load (N)

f_c : Contact Factor

f_w : Load Factor

ABOUT SINGLE AXIS ACTUATOR

1-6 Calculation of Service Life

In a KP-LD, 2 internal slides are used close to each other and when a moment is generated, refer to Table 1.6.2, multiply the equivalent factor with the load moment, having an equivalent load.

$$P_m = K \times M$$

P_m : Equivalent load of the slide(kgf)

K : Moment factor of equivalence (mm)

M : Moment load (kgf×mm)

When apply a M_c moment on a KP-LD :

$$P_m = \frac{K_c \cdot M_c}{2}$$

Apply a radial load (P) and a moment on a KP-LD at the same time :

$$P_E = P + P_m$$

P_E : Total radial load of equivalence (N)

【Service Life】

After a rated service life is calculated, service life can be calculated by using the following formula(Under the circumstances that the travel distance and the number of reciprocating cycles per minute are stable).

$$L_h = \frac{L \cdot 10^6}{2 \cdot \ell_s \cdot N_1 \cdot 60}$$

L_h : Service life (h)

ℓ_s : Distance of travel (mm)

N_1 : No. of reciprocating cycles per minute (min^{-1})

2. Analyze the supporting end of ball screw :

Rating Life

$$L = \left(\frac{C_a}{f_w \cdot F_a} \right)^3 \cdot 10^6$$

L : Service life (rev)

C_a : Basic dynamic rated load (N)

F_a : Value of calculated load (N)

f_w : Load factor (refer to E09. Table 1.6.1)



1-7 Calculation of Service Life/ Lubrication

【Service Life】

After a rated service life is calculated, service life can be calculated by using the following formula (provided that the travel distance and the number of reciprocating cycles per minute are not changed).

$$L_h = \frac{L \cdot l}{2 \cdot l_s \cdot N_1 \cdot 60}$$

L_h : Service life (h)

l_s : Distance of travel (mm)

N_1 : No. of reciprocating cycles per minute (min^{-1})

l : Screw lead (mm)

■ 1-7-1 Notice on Lubrication

Lubrication is essential to Single Axis Actuator, otherwise the friction increase and it may be the main factor of service life shortening. It is suggested that every 100km travel distance Single Axis Actuator should be lubricated through the grease nipple on the slide. Grease only applies to the working environment which is slower than 60/mins and cooling is not required.

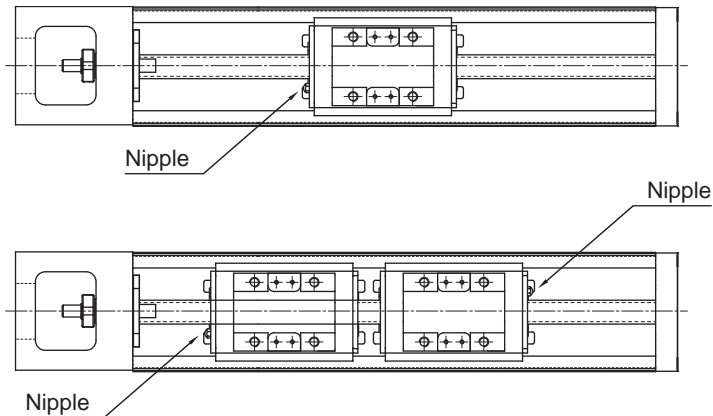

ABOUT SINGLE AXIS ACTUATOR

1-8 KP Product Series

KP26 (Standard Type)

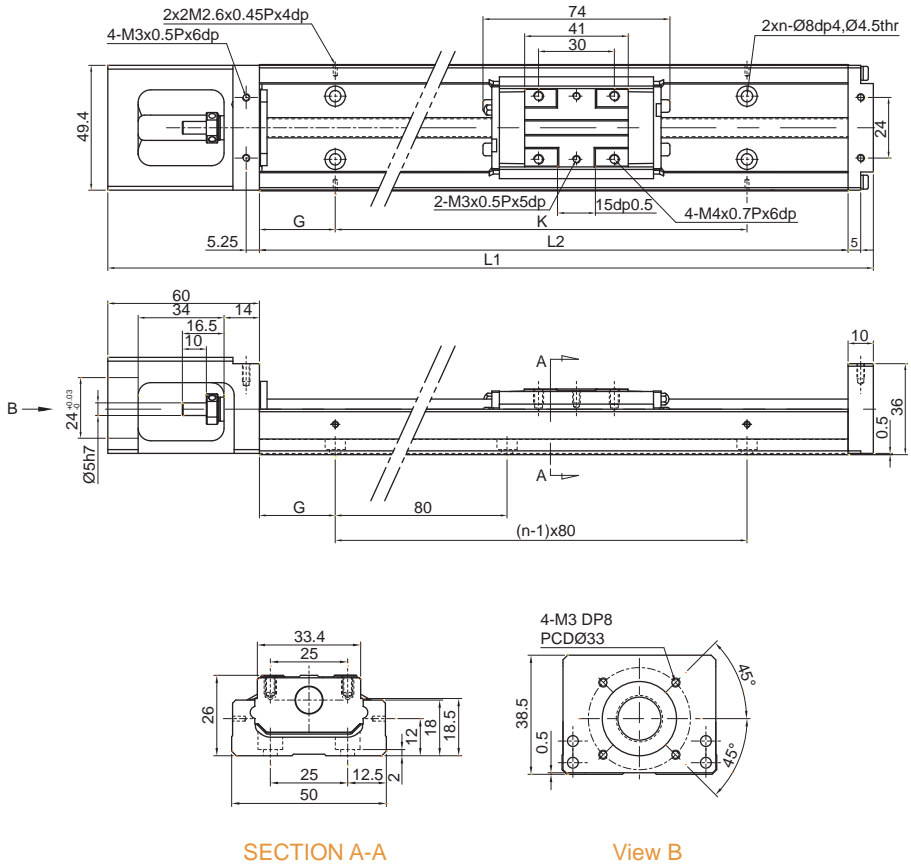

Track length L2(mm)	Overall length L1(mm)	Max.travel(mm)		G(mm)	K(mm)	n	Total weight(kg)	
		LS	LD				LS	LD
150	220	73	-	35	80	2	1	-
200	270	123	54	20	160	3	1.2	1.4
250	320	173	104	45	160	3	1.4	1.6
300	370	223	154	30	240	4	1.6	1.8

※LS slide base : with one slide base, LD slide base : with two slide bases.

KP26 (Standard Type with Protective Cap)

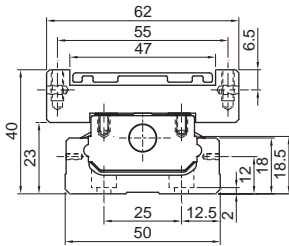
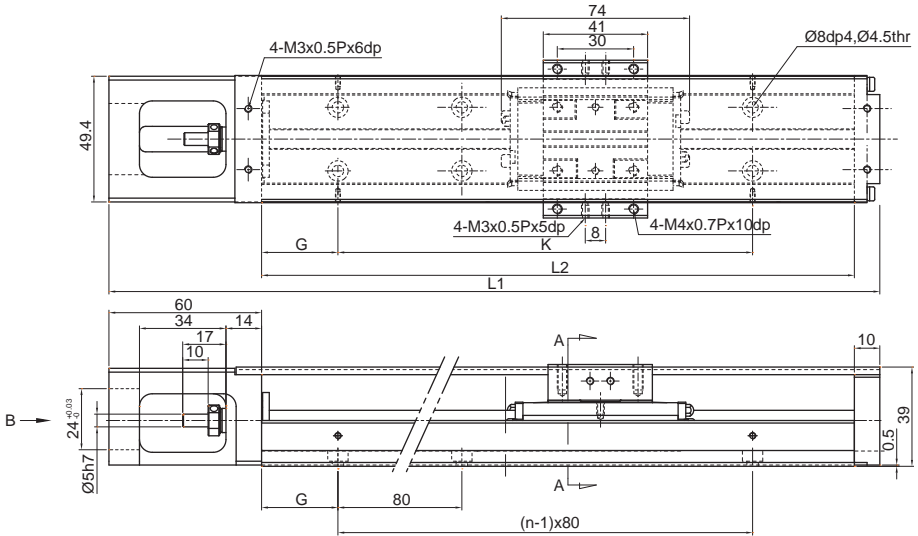

SECTION A-A

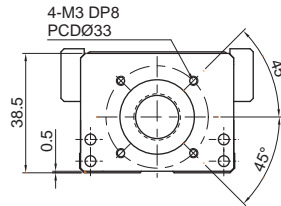

View B

Track length L2(mm)	Overall length L1(mm)	Max.travel(mm)		G(mm)	K(mm)	n	Total weight(kg)	
		LS	LD				LS	LD
150	220	73	-	35	80	2	1.1	-
200	270	123	54	20	160	3	1.3	1.5
250	320	173	104	45	160	3	1.5	1.8
300	370	223	154	30	240	4	1.8	2.0

※ LS slide base : with one slide base, LD slide base : with two slide bases.

ABOUT SINGLE AXIS ACTUATOR

1-8 KP Product Series

KP26 (Low-Assembly)

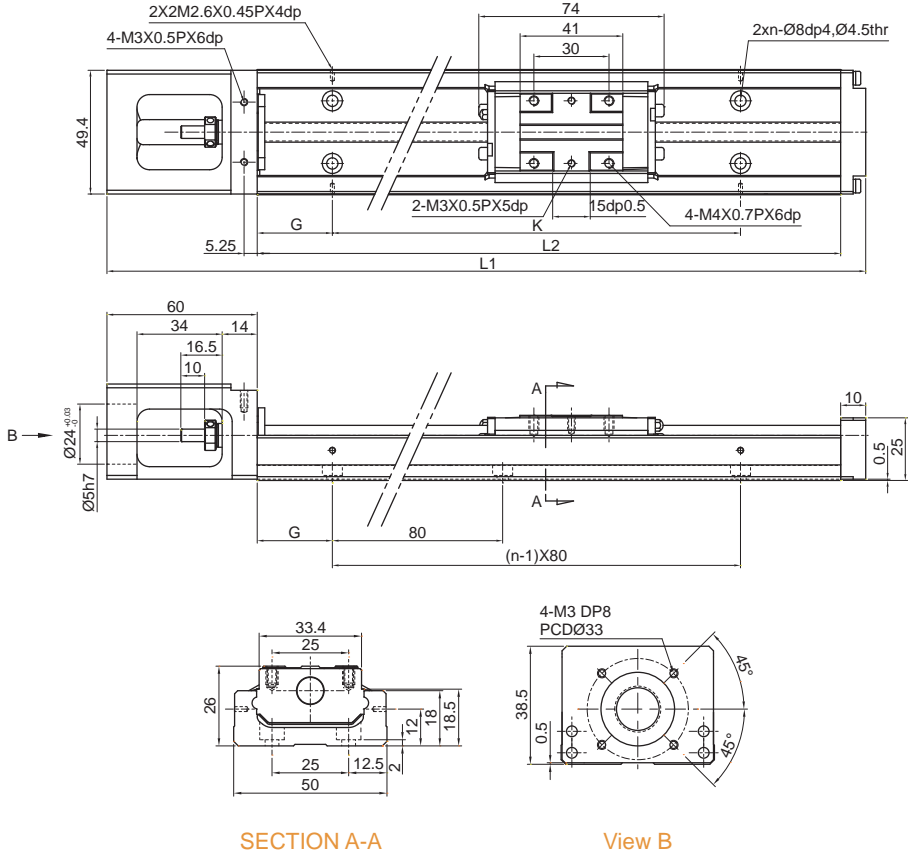

SECTION A-A

View B

Track length L2(mm)	Overall length L1(mm)	Max.travel(mm)		G(mm)	K(mm)	n	Total weight(kg)	
		LS	LD				LS	LD
150	220	73	-	35	80	2	1	-
200	270	123	54	20	160	3	1.2	1.4
250	320	173	104	45	160	3	1.4	1.6
300	370	223	154	30	240	4	1.6	1.8

※LS slide base : with one slide base, LD slide base : with two slide bases.

KP33 (Standard Type)

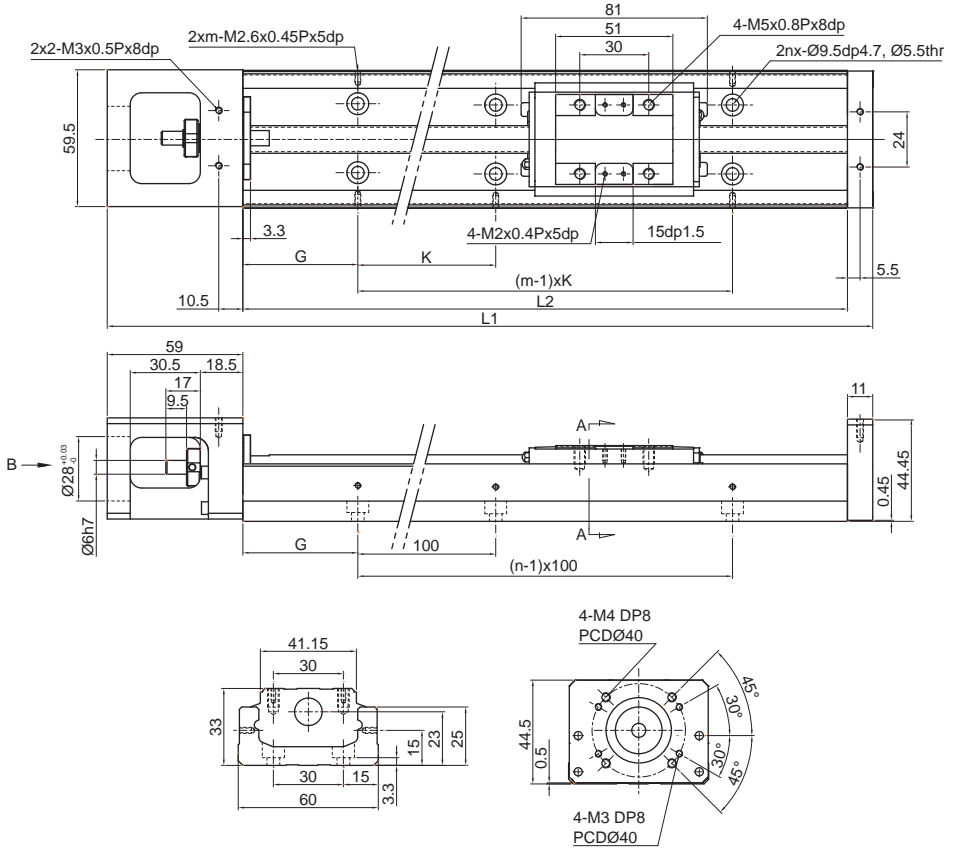

Single Axis Actuator

SECTION A-A

View B

Track length L2(mm)	Overall length L1(mm)	Max.travel(mm)		G(mm)	K(mm)	n	m	Total weight(kg)	
		LS	LD					LS	LD
150	220	63.5	-	25	100	2	2	1.5	-
200	270	113.5	36.5	50	100	2	2	1.8	-
300	370	213.5	136.5	50	200	3	2	2.4	2.7
400	470	313.5	236.5	50	100	4	4	3	3.3
500	570	413.5	336.5	50	200	5	3	3.6	3.9
600	670	513.5	436.5	50	100	6	6	4.2	4.6

※ LS slide base : with one slide base, LD slide base : with two slide bases.

ABOUT SINGLE AXIS ACTUATOR

1-8 KP Product Series

KP33 (Standard Type with Protective Cap)

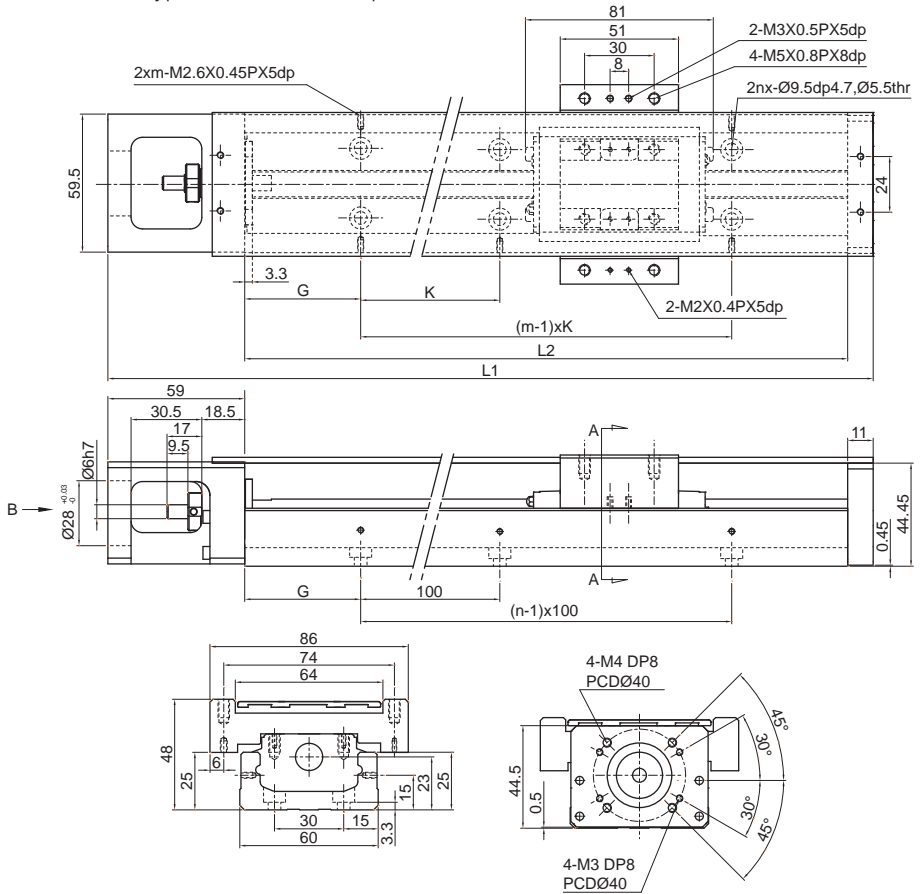

SECTION A-A

View B

Track length L2 (mm)	Overall length L1 (mm)	Max. travel (mm)		G(mm)	K(mm)	n	m	Total weight (kg)	
		LS	LD					LS	LD
150	220	63.5	-	25	100	2	2	1.5	-
200	270	113.5	36.5	50	100	2	2	1.8	-
300	370	213.5	136.5	50	200	3	2	2.4	2.7
400	470	313.5	236.5	50	100	4	4	3	3.3
500	570	413.5	336.5	50	200	5	3	3.6	3.9
600	670	513.5	436.5	50	100	6	6	4.2	4.6

※ LS slide base : with one slide base, LD slide base : with two slide bases.

KP33 (Low-Assembly)

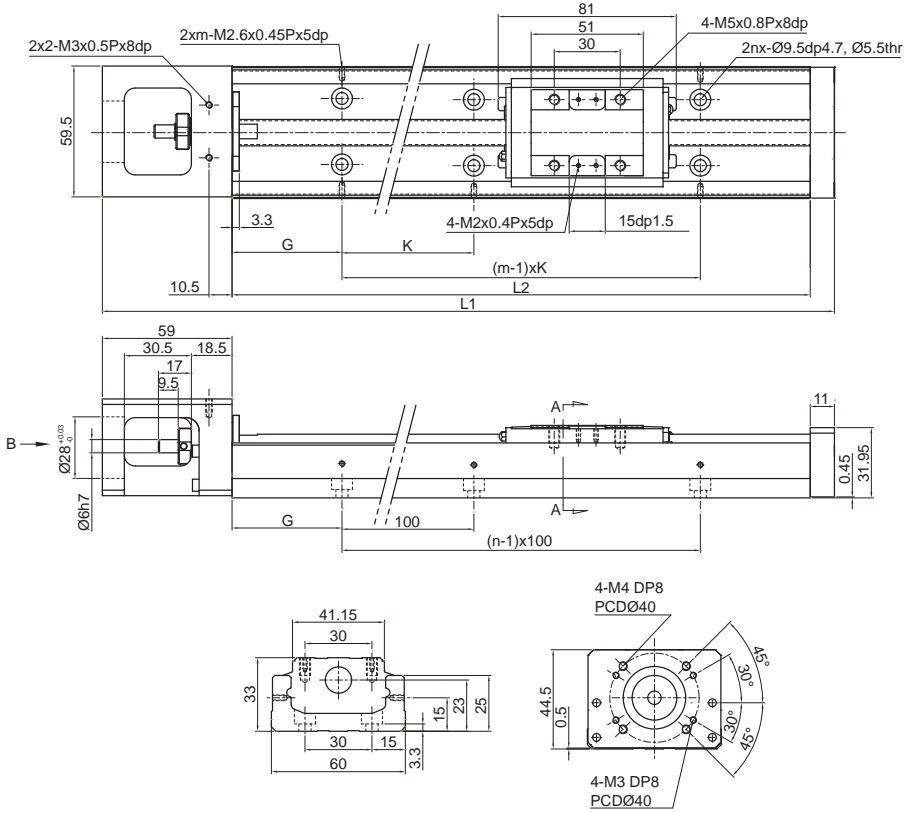

SECTION A-A

View B

Track length L2 (mm)	Overall length L1 (mm)	Max. travel (mm)		G(mm)	K(mm)	n	m	Total weight (kg)	
		LS	LD					LS	LD
150	220	63.5	-	25	100	2	2	1.5	-
200	270	113.5	36.5	50	100	2	2	1.8	-
300	370	213.5	136.5	50	200	3	2	2.4	2.7
400	470	313.5	236.5	50	100	4	4	3	3.3
500	570	413.5	336.5	50	200	5	3	3.6	3.9
600	670	513.5	436.5	50	100	6	6	4.2	4.6

* LS slide base : with one slide base, LD slide base : with two slide bases.

ABOUT SINGLE AXIS ACTUATOR

1-8 KP Product Series

K33 (Light-Load Type)

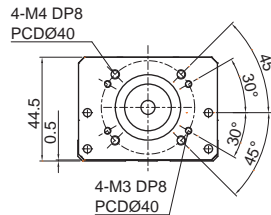
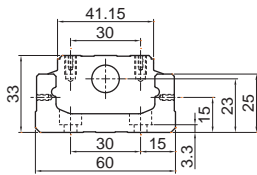
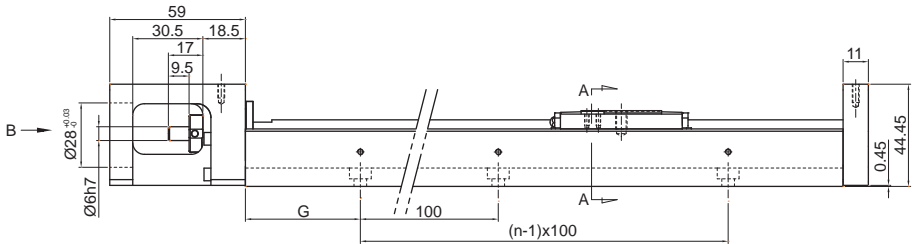
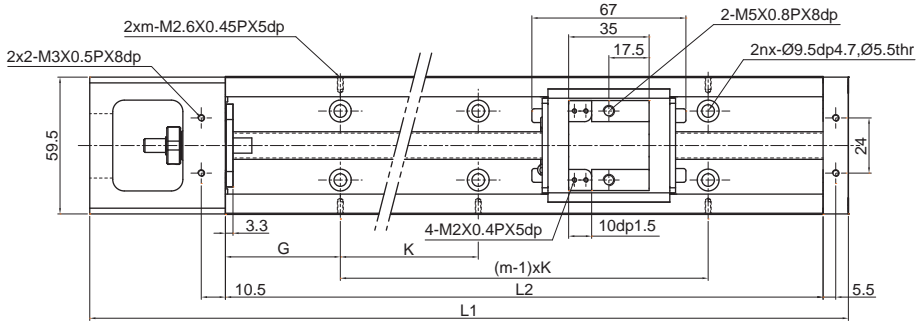

SECTION A-A

View B

Track length L2(mm)	Overall length L1(mm)	Max.travel(mm)		G(mm)	K(mm)	n	m	Total weight(kg)	
		NS	ND					NS	ND
150	220	79.5	-	25	100	2	2	1.4	1.6
200	270	129.5	68.5	50	100	2	2	1.7	1.9
300	370	229.5	168.5	50	200	3	2	2.3	2.5
400	470	329.5	268.5	50	100	4	4	2.9	3.1
500	570	429.5	368.5	50	200	5	3	3.5	3.7
600	670	529.5	468.5	50	100	6	6	4.1	4.3

※ NS slide base : with one slide base, ND slide base : with two slide bases.

KP33 (Light-Load Type with Protective Cap)

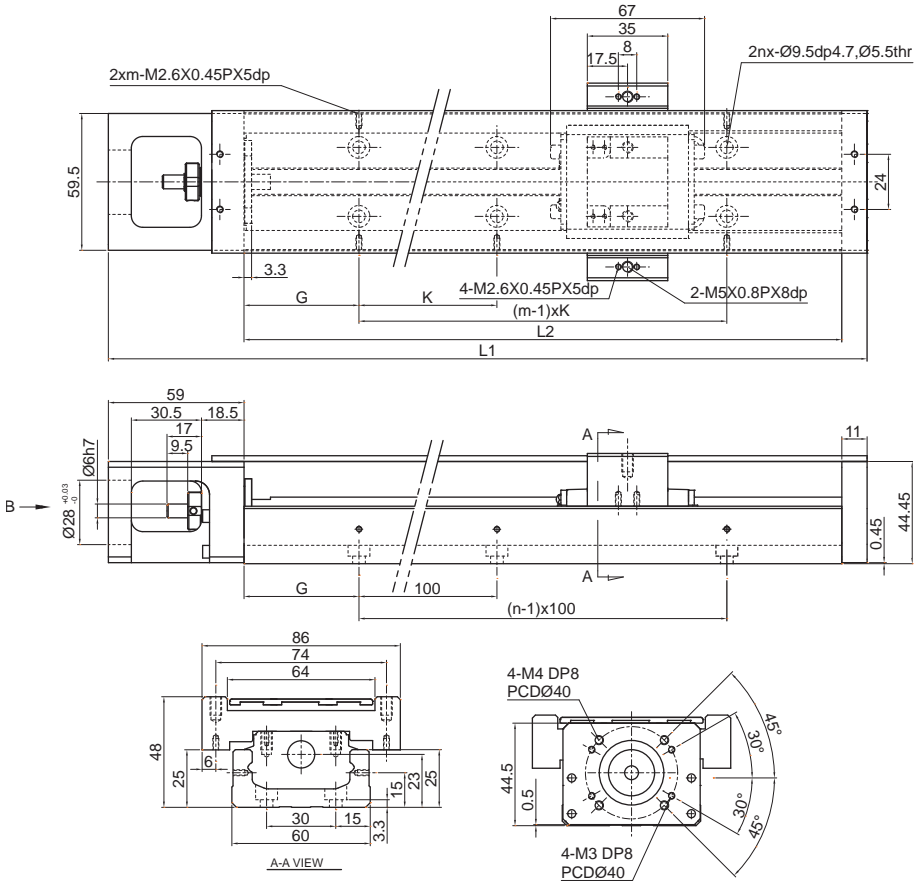

SECTION A-A

View B

Track length L2 (mm)	Overall length L1 (mm)	Max. travel (mm)		G(mm)	K(mm)	n	m	Total weight (kg)	
		NS	ND					NS	ND
150	220	79.5	-	25	100	2	2	1.4	1.6
200	270	129.5	68.5	50	100	2	2	1.7	1.9
300	370	229.5	168.5	50	200	3	2	2.3	2.5
400	470	329.5	268.5	50	100	4	4	2.9	3.1
500	570	429.5	368.5	50	200	5	3	3.5	3.7
600	670	529.5	468.5	50	100	6	6	4.1	4.3

* NS slide base : with one slide base, ND slide base : with two slide bases.

ABOUT SINGLE AXIS ACTUATOR

1-8 KP Product Series

KP33 (Light-Load Type, Low-Assembly)

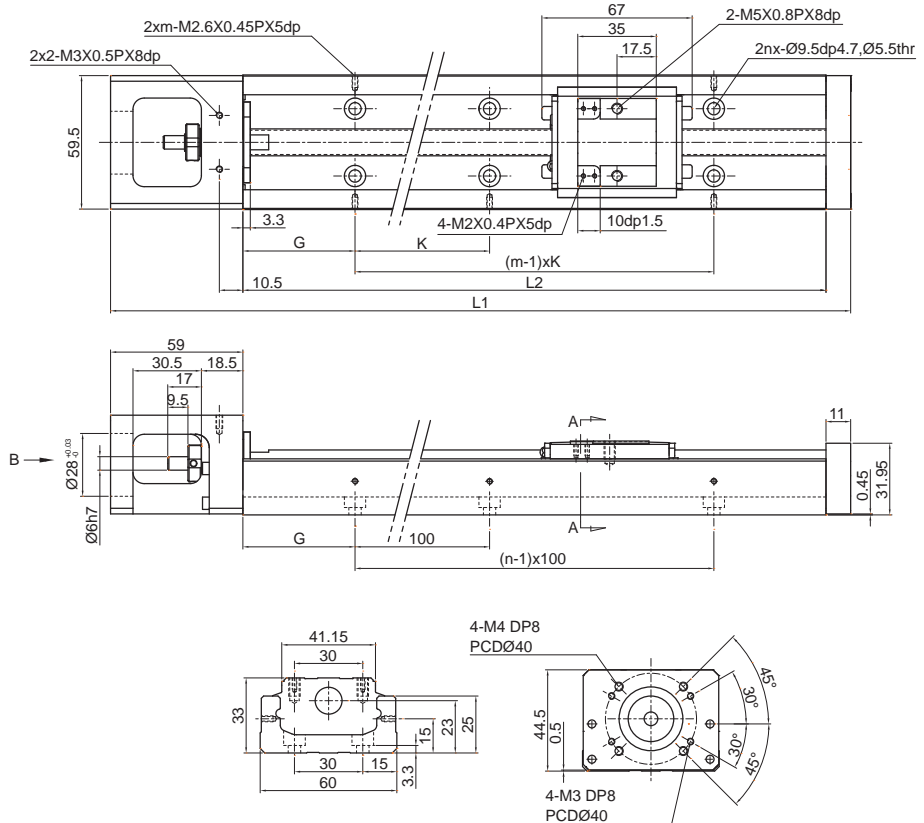

SECTION A-A

View B

Track length L2 (mm)	Overall length L1 (mm)	Max. travel (mm)		G(mm)	K(mm)	n	m	Total weight (kg)	
		NS	ND					NS	ND
150	220	79.5	-	25	100	2	2	1.4	1.6
200	270	129.5	68.5	50	100	2	2	1.7	1.9
300	370	229.5	168.5	50	200	3	2	2.3	2.5
400	470	329.5	268.5	50	100	4	4	2.9	3.1
500	570	429.5	368.5	50	200	5	3	3.5	3.7
600	670	529.5	468.5	50	100	6	6	4.1	4.3

* NS slide base : with one slide base, ND slide base : with two slide bases.

KP46 (Standard Type)

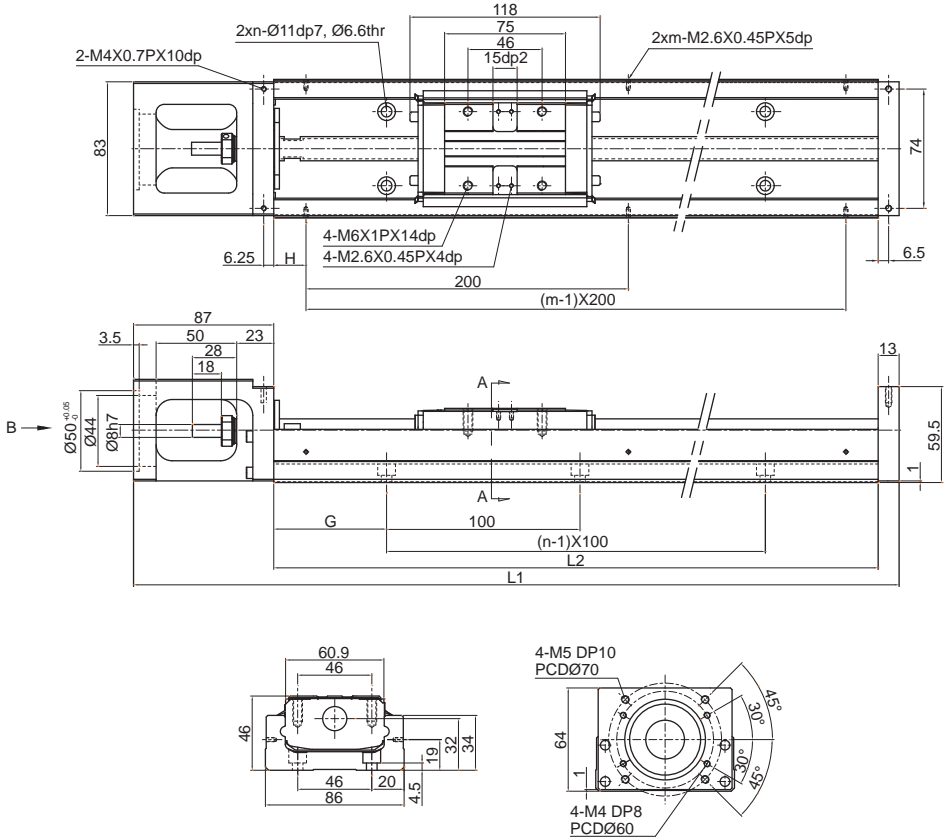

SECTION A-A

View B

Track length L2 (mm)	Overall length L1 (mm)	Max. travel (mm)		G(mm)	n	m	Total weight (kg)	
		LS	LD				LS	LD
340	440	218.5	106.5	70	3	2	5.7	6.5
440	540	318.5	206.5	20	4	3	6.9	7.7
540	640	418.5	306.5	70	5	3	8	8.8
640	740	518.5	406.5	20	6	4	9.2	10.1
740	840	618.5	506.5	70	7	4	10.4	11.3
940	1040	818.5	706.5	70	9	5	11.6	12.5

※ LS slide base : with one slide base, LD slide base : with two slide bases.

ABOUT SINGLE AXIS ACTUATOR

1-8 KP Product Series

KP46 (Standard Type with Protective Cap)

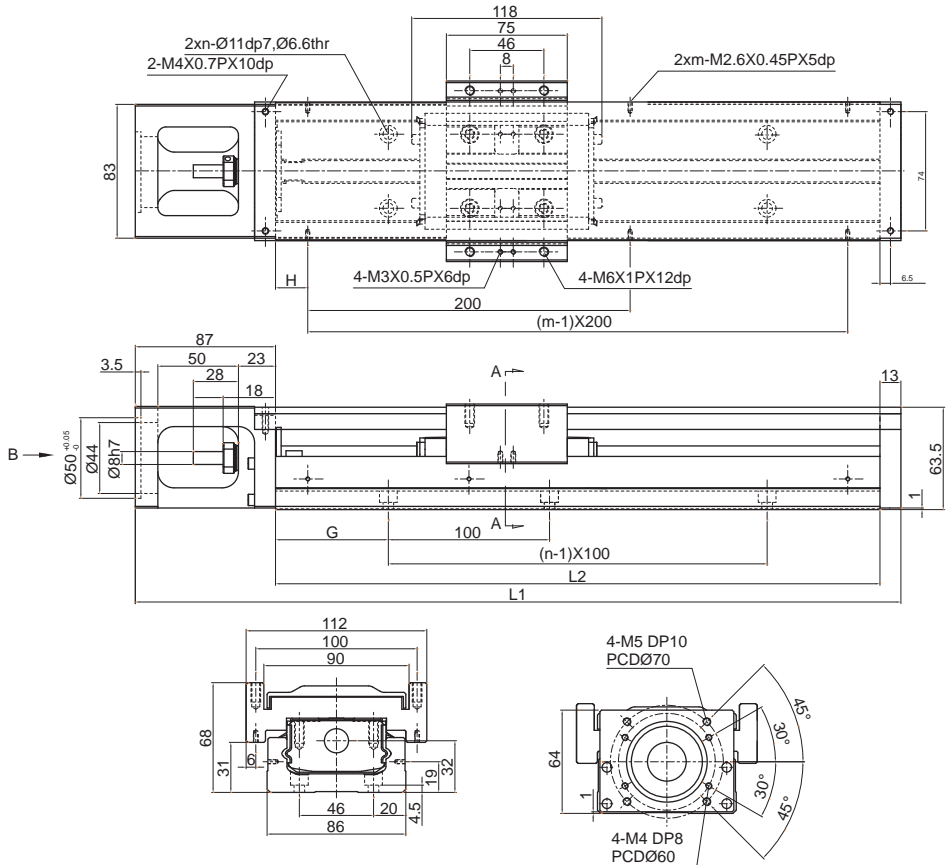

SECTION A-A

View B

Track length L2 (mm)	Overall length L1 (mm)	Max. travel (mm)		G(mm)	n	m	Total weight (kg)	
		LS	LD				LS	LD
340	440	218.5	106.5	70	3	2	6.5	7.3
440	540	318.5	206.5	20	4	3	7.8	8.6
540	640	418.5	306.5	70	5	3	9.0	9.8
640	740	518.5	406.5	20	6	4	10.3	11.3
740	840	618.5	506.5	70	7	4	11.6	12.4
940	1040	818.5	706.5	70	9	5	13.0	13.8

※LS slide base : with one slide base, LD slide base : with two slide bases.

KP46 (Low-Assembly)

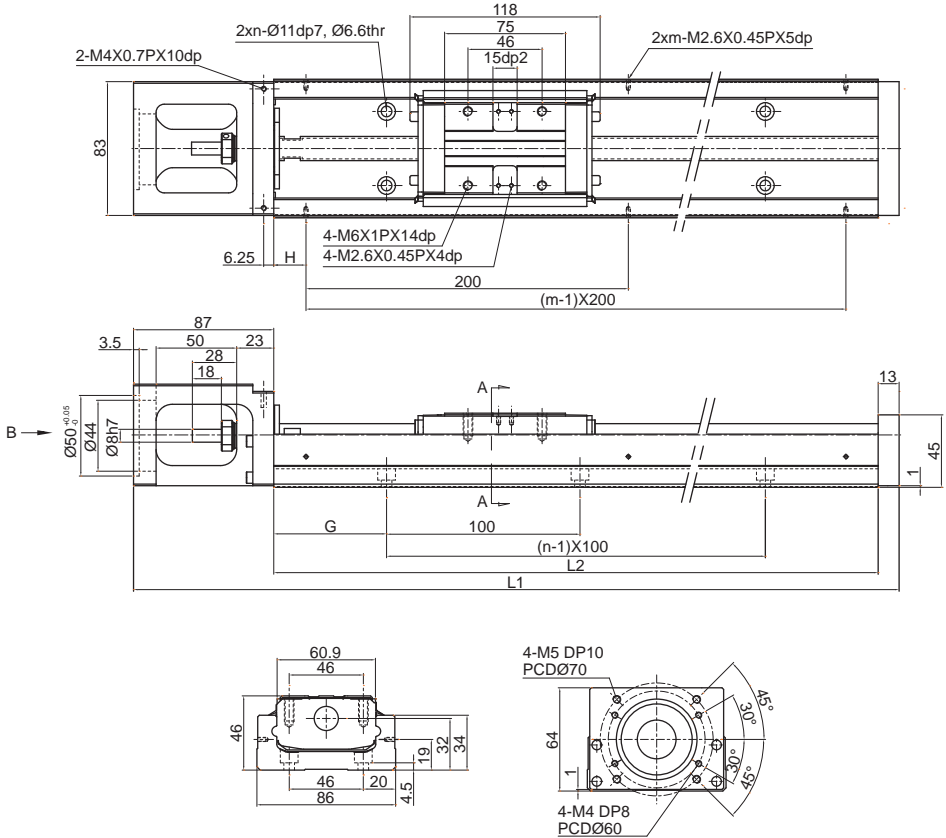

SECTION A-A

View B

Track length L2 (mm)	Overall length L1 (mm)	Max. travel (mm)		G(mm)	n	m	Total weight (kg)	
		LS	LD				LS	LD
340	440	218.5	106.5	70	3	2	6.5	7.3
440	540	318.5	206.5	20	4	3	7.8	8.6
540	640	418.5	306.5	70	5	3	9.0	9.8
640	740	518.5	406.5	20	6	4	10.3	11.3
740	840	618.5	506.5	70	7	4	11.6	12.4
940	1040	818.5	706.5	70	9	5	13.0	13.8

※LS slide base : with one slide base, LD slide base : with two slide bases.

ABOUT SINGLE AXIS ACTUATOR

1-8 KP Product Series

K46 (Light-Load Type)

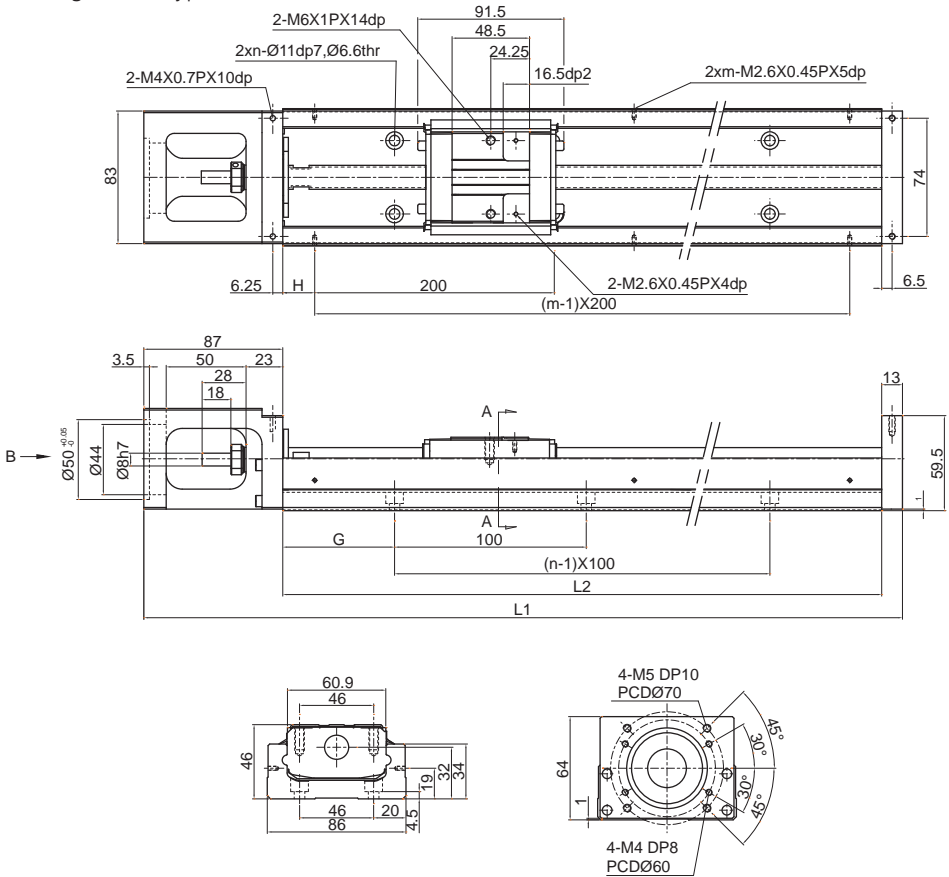

SECTION A-A

View B

Track length L2 (mm)	Overall length L1 (mm)	Max. travel (mm)		G(mm)	n	m	Total weight (kg)	
		NS	ND				NS	ND
340	440	245	159.5	70	3	2	5.4	5.9
440	540	345	259.5	20	4	3	6.6	7.1
540	640	445	359.5	70	5	3	7.7	8.2
640	740	545	459.5	20	6	4	8.9	9.4
740	840	645	559.5	70	7	4	10.1	10.6
940	1040	845	759.5	70	9	5	11.3	11.8

※NS slide base : with one slide base, ND slide base : with two slide bases.

KP46 (Light-Load Type with Protective Cap)

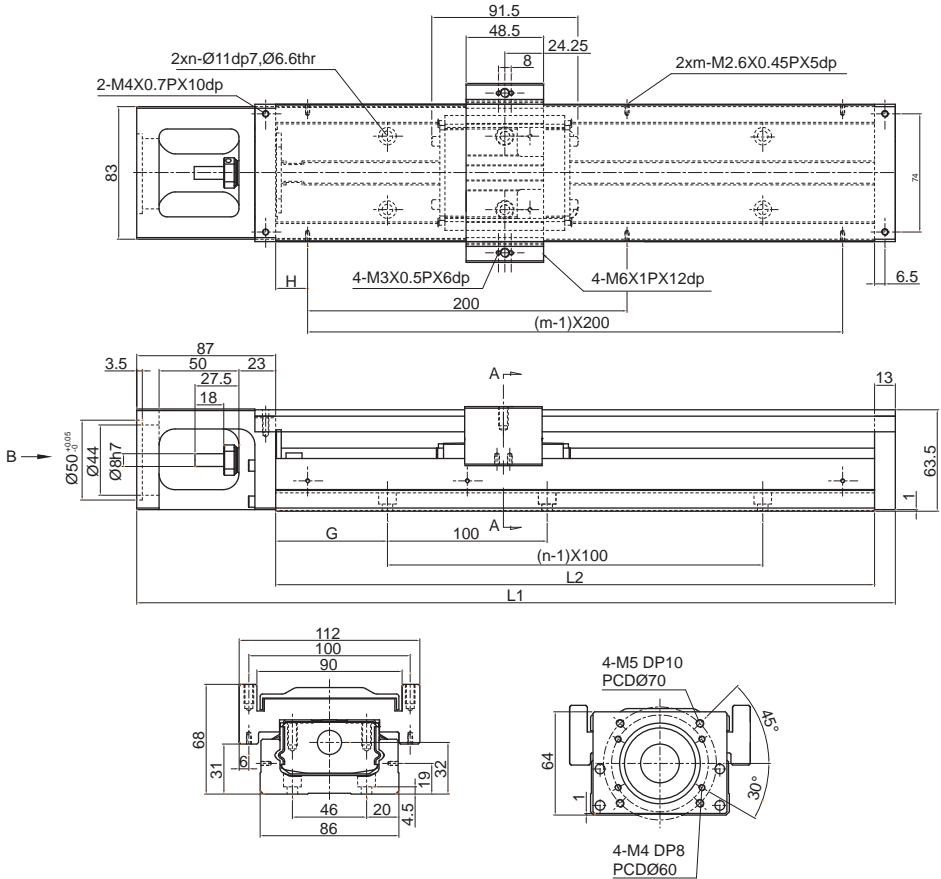

SECTION A-A

View B

Track length L2 (mm)	Overall length L1 (mm)	Max. travel (mm)		G(mm)	n	m	Total weight (kg)	
		NS	ND				NS	ND
340	440	245	159.5	70	3	2	6.3	7.1
440	540	345	259.5	20	4	3	7.6	8.4
540	640	445	359.5	70	5	3	8.8	9.6
640	740	545	459.5	20	6	4	10.1	11.1
740	840	645	559.5	70	7	4	11.4	12.2
940	1040	845	759.5	70	9	5	12.8	13.6

※NS slide base : with one slide base, ND slide base : with two slide bases.

ABOUT SINGLE AXIS ACTUATOR

1-8 KP Product Series

KP46 (Light-Load Type, Low-Assembly)

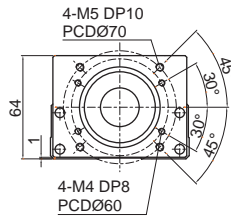
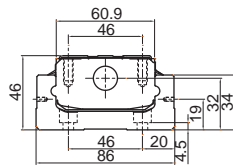
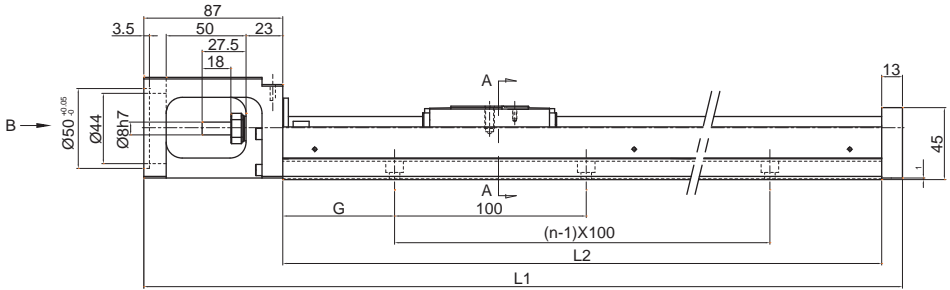
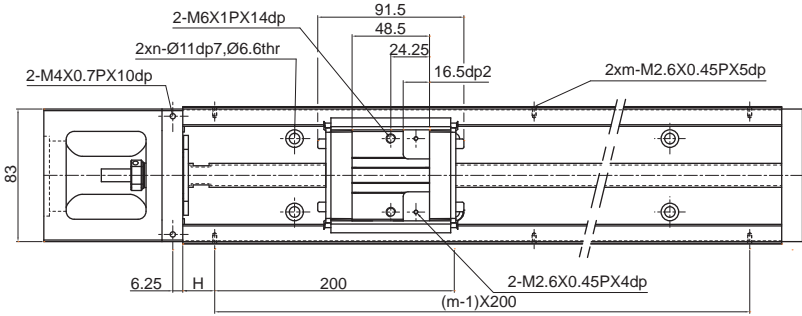

SECTION A-A

View B











Track length L2 (mm)	Overall length L1 (mm)	Max. travel (mm)		G(mm)	n	m	Total weight (kg)	
		NS	ND				NS	ND
340	440	245	159.5	70	3	2	6.3	7.1
440	540	345	259.5	20	4	3	7.6	8.4
540	640	445	359.5	70	5	3	8.8	9.6
640	740	545	459.5	20	6	4	10.1	11.1
740	840	645	559.5	70	7	4	11.4	12.2
940	1040	845	759.5	70	9	5	12.8	13.6

※NS slide base : with one slide base, ND slide base : with two slide bases.

1-9 The Adapting Flange of the Motor Base and the Motor

1-9-1 List of Suitable Motors









Table 1.9.1 Mitsubishi Servo Motors

NO.	Power Output	Motor	weight (kg)	Suitable Flange			Brake (kg)	Drive	weight (kg)	Remarks
				KP26	KP33	KP46				
M01	50W	HG-KR053	0.34	F01	F05	F12	-	MR-J4-10A	0.8	220V 
M02	50W	HG-KR053K	0.34	F01	F05	F12	-	MR-J4-10A	0.8	220V 
M03	100W	HG-KR13	0.54	F01	F05	F12	-	MR-J4-10A	0.8	220V 
M04	100W	HG-KR13K	0.54	F01	F05	F12	-	MR-J4-10A	0.8	220V 
M05	200W	HG-KR23	0.91	-	-	F10	-	MR-J4-20A	0.8	220V 
M06	200W	HG-KR23K	0.91	-	-	F10	-	MR-J4-20A	0.8	220V 
M07	400W	HG-KR43	1.4	-	-	F10	-	MR-J4-40A	1	220V 
M08	400W	HG-KR43K	1.4	-	-	F10	-	MR-J4-40A	1	220V 
M09	750W	HG-KR73	2.8	-	-	-	-	MR-J4-70A	1.4	220V 
M10	750W	HG-KR73K	2.8	-	-	-	-	MR-J4-70A	1.4	220V 

(1) A Single Axis Actuator includes a servo motor with supply wire, detector connecting wire and servo connector, supply wire and detector connecting wire are 3 meters long. 3m supply wire(3m, MIT) MR-PW51CBL3M-A2-L-T/ 3m detector connecting wire(3m, MIT)MR-J3ENCBL3M-A2-L-T, servo connector SMR-J3CN1.













(2) Exclude the battery of absolute position detecting system.

Table 1.9.2 Panasonic Servo Motors

NO.	Power Output	Motor	weight (kg)	Suitable Flange			Brake (kg)	Drive	weight (kg)	Remarks
				KP26	KP33	KP46				
M11	50W	MSMF5AZL1U2	0.32	F02	F06	F13	0.53	MADLN01SE	0.8	210V 
M12	50W	MSMF5AZL1U2	0.32	F02	F06	F13	0.53	MADLN05SE	0.8	220V 
M13	100W	MSMF011L1U2	0.47	F02	F06	F13	0.68	MADLN11SE	0.8	210V 
M14	100W	MSMF012L1U2	0.47	F02	F06	F13	0.68	MADLN05SE	0.8	220V 
M15	200W	MSMF021L1U2	0.82	-	-	F11	1.3	MBDLN21SE	1	210V 
M16	200W	MSMF022L1U2	0.82	-	-	F11	1.3	MADLN15SE	0.8	220V 
M17	400W	MSMF041L1U2	1.2	-	-	F11	1.7	MCDLN31SE	1.6	210V 
M18	400W	MSMF042L1U2	1.2	-	-	F11	1.7	MBDLN25SE	1	220V 
M19	750W	MSMF082L1U2	2.3	-	-	-	3.1	MCDLN35SE	1.6	220V 

(1) A single axis actuator includes a servo motor with supply wire, coding wire, I/F adaptor, supply wire and coding wire are 1m, 3m or 5m long, without designation wires would be 3 meters long.





















(2) Exclude the battery of absolute position detecting system.

Incremental type	Pulse type	D-Axis	Low-inertia	Medium-inertia	Low-capacity	No Grease Seal	Grease Seal	With Brake	No Brake	Key Way	Key Way, Threaded Hole	Optical Axis
												

ABOUT SINGLE AXIS ACTUATOR

1-9 The Adapting Flange of the Motor Base and the Motor

Table 1.9.3 Yaskawa Servo Motors

NO.	Power Output	Motor	weight (kg)	Suitable Flange			Brake (kg)	Drive	weight (kg)	Remarks
				KP26	KP33	KP46				
M20	50W	SGM7J-A5AF61	0.3	F01	F05	F12	-	SGD7S-R70A00A	0.8	220V 
M21	50W	SGM7J-A5AF6C	0.6	F01	F05	F12	0.6	SGD7S-R70A00A	0.8	220V 
M22	50W	SGM7J-A5AF6S	0.3	F01	F05	F12	-	SGD7S-R70A00A	0.8	220V 
M23	50W	SGM7J-A5AF6E	0.6	F01	F05	F12	0.6	SGD7S-R70A00A	0.8	220V 
M24	100W	SGM7J-01AF61	0.4	F01	F05	F12	-	SGD7S-R90A00A	0.8	220V 
M25	100W	SGM7J-01AF6C	0.7	F01	F05	F12	0.7	SGD7S-R90A00A	0.8	220V 
M26	100W	SGM7J-01AF6S	0.4	F01	F05	F12	-	SGD7S-R90A00A	0.8	220V 
M27	100W	SGM7J-01AF6E	0.7	F01	F05	F12	0.7	SGD7S-R90A00A	0.8	220V 
M28	200W	SGM7J-02AF61	0.8	-	-	F10	-	SGD7S-1R6A00A	0.8	220V 
M29	200W	SGM7J-02AF6C	1.4	-	-	F10	1.4	SGD7S-1R6A00A	0.8	220V 
M30	200W	SGM7J-02AF6S	0.8	-	-	F10	-	SGD7S-1R6A00A	0.8	220V 
M31	200W	SGM7J-02AF6E	1.4	-	-	F10	1.4	SGD7S-1R6A00A	0.8	220V 
M32	400W	SGM7J-04AF61	1.1	-	-	F10	-	SGD7S-2R8A00A	1	220V 
M33	400W	SGM7J-04AF6C	1.7	-	-	F10	1.7	SGD7S-2R8A00A	1	220V 
M34	400W	SGM7J-04AF6S	1.1	-	-	F10	-	SGD7S-2R8A00A	1	220V 
M35	400W	SGM7J-04AF6E	1.7	-	-	F10	1.7	SGD7S-2R8A00A	1	220V 
M36	750W	SGM7J-08AF61	2.2	-	-	-	-	SGD7S-5R5A00A	1.6	220V 
M37	750W	SGM7J-08AF6C	2.8	-	-	-	2.8	SGD7S-5R5A00A	1.6	220V 
M38	750W	SGM7J-08AF6S	2.2	-	-	-	-	SGD7S-5R5A00A	1.6	220V 
M39	750W	SGM7J-08AF6E	2.8	-	-	-	2.8	SGD7S-5R5A00A	1.6	220V 

(1) A single axis actuator includes a servo motor with supply wire, coding wire and servo connector, supply wire and coding wire are 3 meters long.

3m supply wire(No actuator) JZSP-C7M10F-03-E(50W), JZSP-C7M20F-03-E(100W, 200W, 400W), JZSP-C7M30F-03-E(750W)

3m supply wire(with actuator) JZSP-C7M13F-03-E(50W), JZSP-C7M23F-03-E(100W, 200W, 400W), JZSP-C7M33-03-E-(750W)

coding wire JZSP-C7P10D-03-E CN1 adaptor 3M-MDR(50P)













Incremental type	Pulse type	D-Axis	Low-inertia	Medium-inertia	Low-capacity	No Grease Seal	Grease Seal	With Brake	No Brake	Key Way	Key Way, Threaded Hole	Optical Axis
												

Table 1.9.4 Oriental Step Motors

















NO.	Series	Specification	Suitable Flange			Motor	weight (kg)	Drive	weight (kg)	Remarks
			KP26	KP33	KP46					
M40	RK II	RKS543AA-3	F03	F09	-	PKE543AC	0.26	RKSD503-A	0.8	110V
M41		RKS544AA-3	F03	F09	-	PKE544AC	0.32	RKSD503-A	0.8	
M42		RKS545AA-3	F03	F09	-	PKE545AC	0.38	RKSD503-A	0.8	
M43		RKS566AA-3	-	-	F15	PKE566AC	0.9	RKSD507-A	0.8	
M44		RKS569AA-3	-	-	F15	PKE569AC	1.4	RKSD507-A	0.8	
M45		RKS596AA-3	-	-	-	PKE596AC	1.9	RKSD507-A	0.8	
M46		RKS599AA-3	-	-	-	PKE599AC	3	RKSD507-A	0.8	
M47		RKS5913AA-3	-	-	-	PKE5913AC	4.1	RKSD507-A	0.8	

※Include 3 meters long supply wire for servo motor.

ABOUT SINGLE AXIS ACTUATOR

1-9 The Adapting Flange of the Motor Base and the Motor

Table 1.9.5 Shihlin Motors













NO.	Power Output	Motor	weight (kg)	Suitable Flange			Brake (kg)	Drive	weight (kg)	Remarks
				KP26	KP33	KP46				
M48	100W	SME-L01030SAA	0.45	F01	F05	F12	-	SDE-010A2	1.4	220V 
M49	100W	SME-L01030SAB	0.45	F01	F05	F12	-	SDE-010A2	1.4	220V 
M50	100W	SME-L01030SBA	0.67	F01	F05	F12	0.67	SDE-010A2	1.4	220V 
M51	100W	SME-L01030SBB	0.67	F01	F05	F12	0.67	SDE-010A2	1.4	220V 
M52	200W	SME-L02030SAA	0.85	-	-	F10	-	SDE-020A2	1.4	220V 
M53	200W	SME-L02030SAB	0.85	-	-	F10	-	SDE-020A2	1.4	220V 
M54	200W	SME-L02030SBA	1.23	-	-	F10	1.23	SDE-020A2	1.4	220V 
M55	200W	SME-L02030SBB	1.23	-	-	F10	1.23	SDE-020A2	1.4	220V 
M56	400W	SME-L04030SAA	1.23	-	-	F10	-	SDE-040A2	1.4	220V 
M57	400W	SME-L04030SAB	1.23	-	-	F10	-	SDE-040A2	1.4	220V 
M58	400W	SME-L04030SBA	1.59	-	-	F10	1.59	SDE-040A2	1.4	220V 
M59	400W	SME-L04030SBB	1.59	-	-	F10	1.59	SDE-040A2	1.4	220V 
M60	750W	SME-L07530SAA	2.24	-	-	-	-	SDE-075A2	1.7	220V 
M61	750W	SME-L07530SAB	2.24	-	-	-	-	SDE-075A2	1.7	220V 
M62	750W	SME-L07530SBA	2.87	-	-	-	2.87	SDE-075A2	1.7	220V 
M63	750W	SME-L07530SBB	2.87	-	-	-	2.87	SDE-075A2	1.7	220V 

※(1) A single axis actuator includes a servo motor with supply wire, coding wire, I/F adaptor, supply wire and coding wire are mainly 3 meters long.

Supply wire SDA-PWCNL1-3M-L

Supply wire(for brake) SDA-PWCNL2-3M-L

Coding wire SDH-ENL-3M-L

Incremental type	Pulse type	D-Axis	Low-inertia	Medium-inertia	Low-capacity	No Grease Seal	Grease Seal	With Brake	No Brake	Key Way	Key Way, Threaded Hole	Optical Axis
												

1-9-2 The Adapting Flange of the Motor Base and the Motor

KP26

Motor Base F00

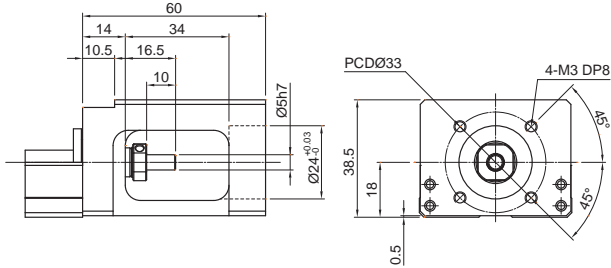

Motor Adapting Flange F01

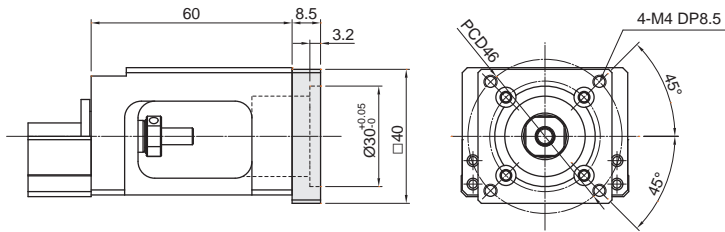

Motor Adapting Flange F02

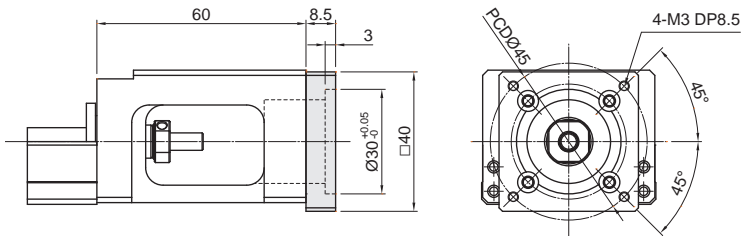

Motor Adapting Flange F03

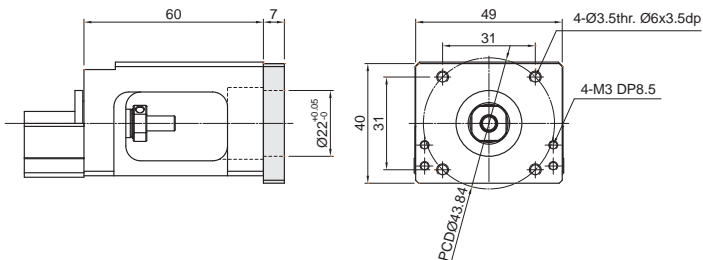

ABOUT SINGLE AXIS ACTUATOR

1-9 The Adapting Flange of the Motor Base and the Motor

KP33

Motor Base F04

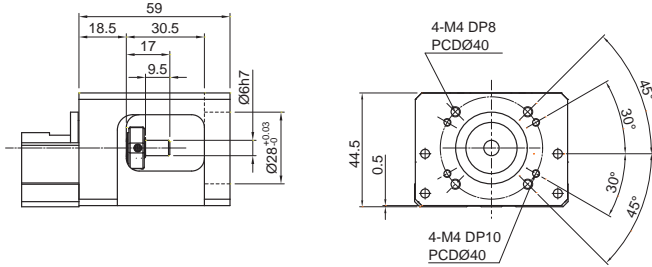

Motor Adapting Flange F05

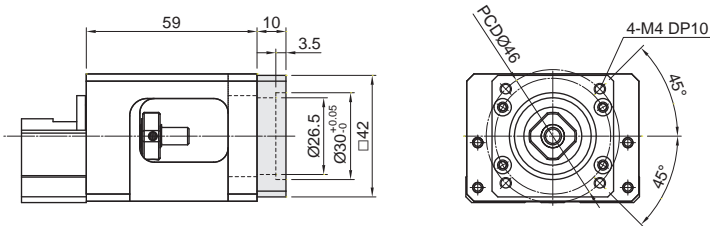

Motor Adapting Flange F06

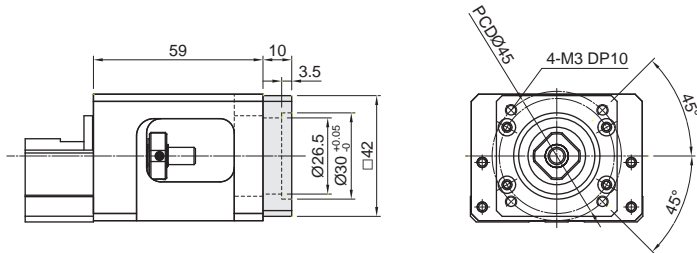

Motor Adapting Flange F07

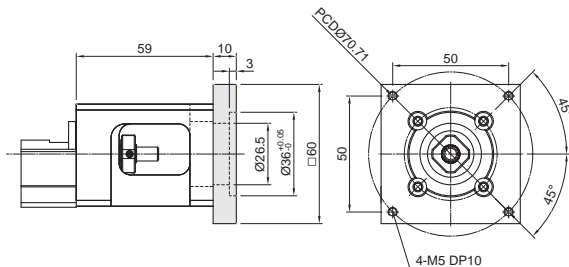

Single Axis Actuator

KP33

Motor Adapting Flange F08

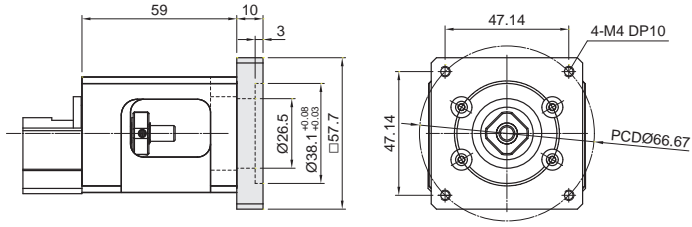

Motor Adapting Flange F09

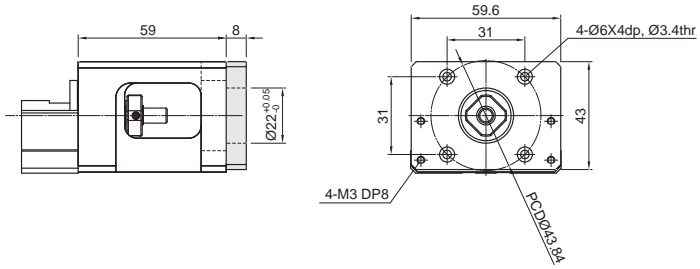

ABOUT SINGLE AXIS ACTUATOR

1-9 The Adapting Flange of the Motor Base and the Motor

KP46

Motor Base F10

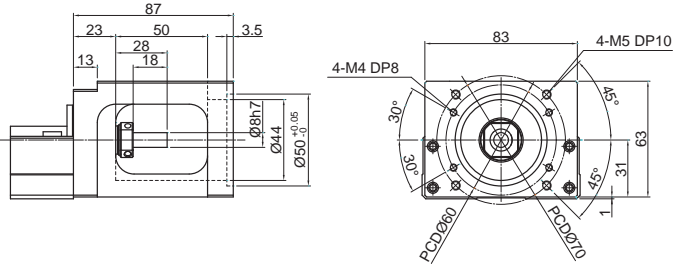

Motor Adapting Flange F11

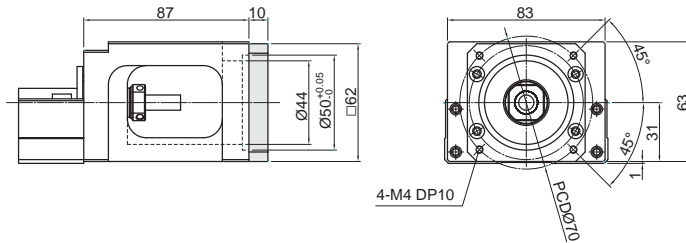

Motor Adapting Flange F12

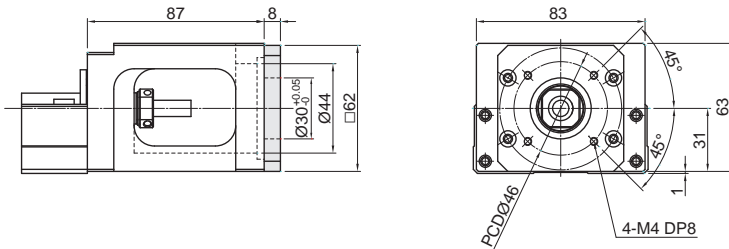

Motor Adapting Flange F13

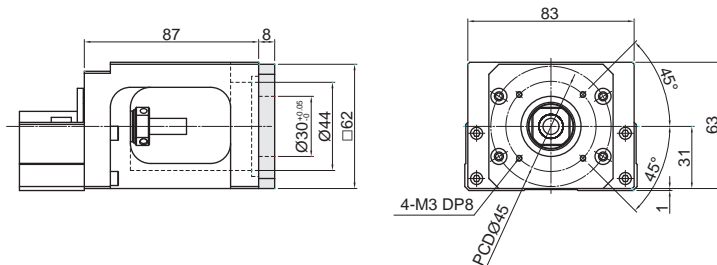

Single Axis Actuator

KP46

Motor Adapting Flange F14

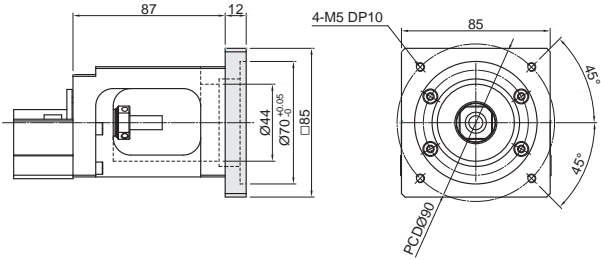

Motor Adapting Flange F15

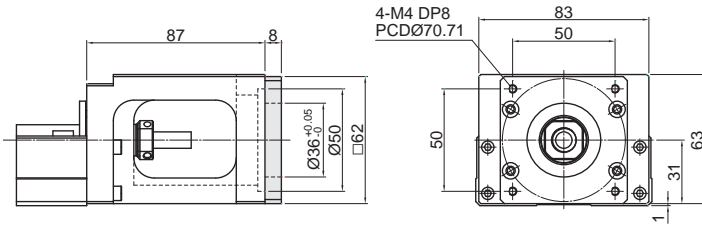

Motor Adapting Flange F16

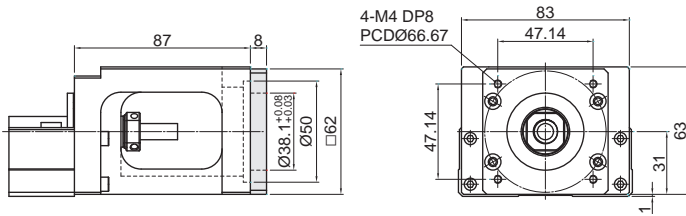

ABOUT SINGLE AXIS ACTUATOR

1-9 The Adapting Flange of the Motor Base and the Motor

■ 1-9-3 Sensor

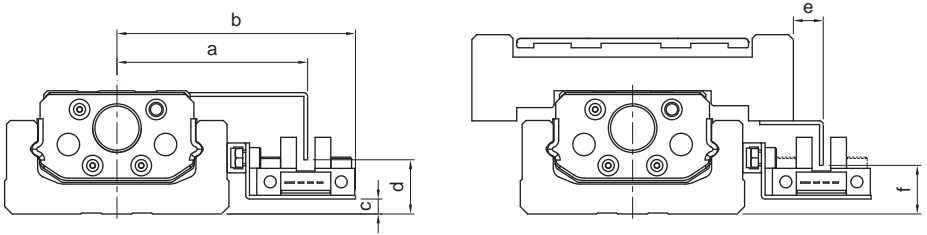

NO.	Nominal Model	a	b	c	d	e	f
S04	KP26	45.5	59	1	10	15	11
S05	KP33	51	63.8	4	14.5	8	13
S06	KP46	63.5	76.7	8	18	8	18

Sensor 1 : Omron EE-SX671.

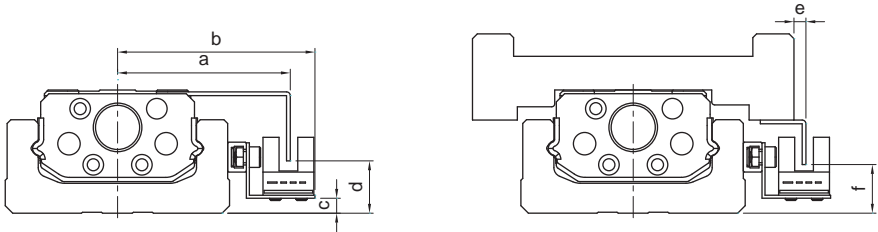

NO.	Nominal Model	a	b	c	d	e	f
S07	KP26	41.3	48	1	10.5	10.2	11
S08	KP33	46.2	52.8	4	14	3.2	13
S09	KP46	59	65.7	8	18	3	18

Sensor 2 : Omron EE-SX674.



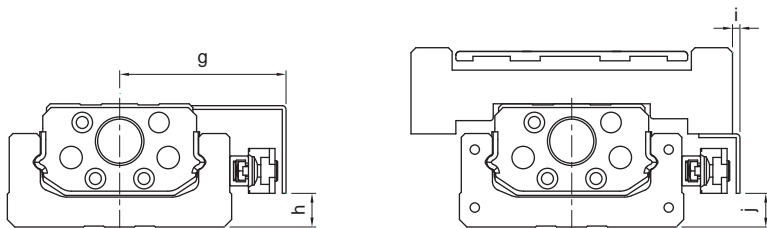

NO.	Nominal Model	g	h	i	j
S10	KP26	39.5	5.7	7	19.5
S11	KP33	44.5	9	2	9
S12	KP46	57	13	1	13

Sensor 3 : SUNX GX-F12A.

NO.	Nominal Model	g	h	i	j
S13	KP26	39.5	5.7	7	19.5
S14	KP33	44.5	9	2	9
S15	KP46	57	13	1	13

Sensor 4 : SUNX GX-F12A-P.

■ 1-9-4 Sensor Track

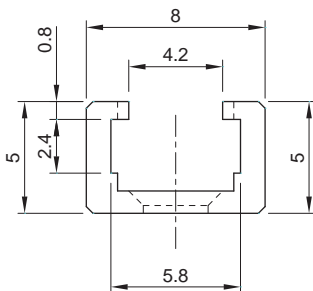
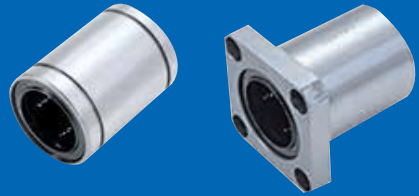

Table 1.9.6 List of Suitable Tracks

NO.	Nominal Model
S01	KP26
S02	KP33
S03	KP46

Linear Ball Bearing



1-1 Features of TBI MOTION Linear Ball Bearing	F02
LM Series Specifications (Standard)	F02
LM-L Series Specifications (Lengthen)	F03
LF Series Specifications (Flange Type)	F04
LF-L Series Specifications (Flange Type with Lengthen Nut)	F05
LU/LP Series Specifications (Aluminum Housing Type)	F06
SF/WV Series Specifications (Shaft)	F07
SS Series Specifications (Shaft Support)	F08

ABOUT LINEAR BALL BEARING

1-1 Features of *TBI MOTION* Linear Ball Bearing

LM Series Specifications (Standard)

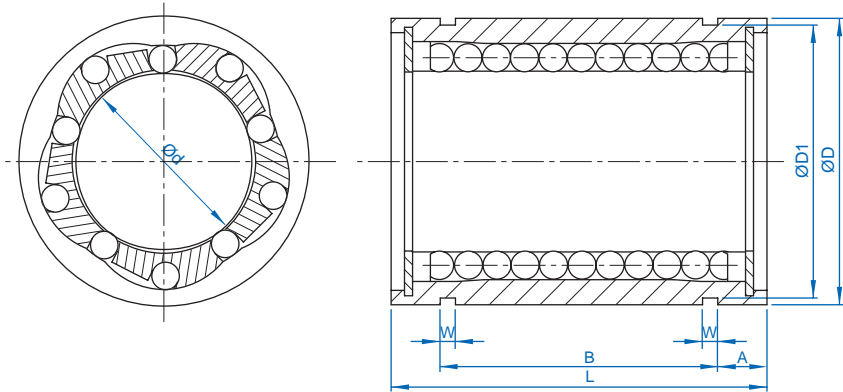

Unit : mm

ModelNo.	Dimension								Ca (kgf)	Coa (kgf)	Weight (g)	
	d	D	Tolerance (μm)	L	LTolerance (μm)	W	D1	B				A
LM-04UU	4	8	0 -11	12	0 -20	-	-	-	-	9	13	2
LM-06UU	6	12		19		1.1	11.5	13.5	2.75	21	27	8
LM-08UU	8	15		24		1.1	14.3	17.5	3.25	27	41	16
LM-10UU	10	19	0 -13	29		1.3	18	22	3.5	38	56	30
LM-12UU	12	21		30		1.3	20	23	3.5	42	61	31.5
LM-16UU	16	28		37		1.6	27	26.5	5.25	79	120	69
LM-20UU	20	32	0 -16	42		0 -30	1.6	30.5	30.5	5.75	88	140
LM-25UU	25	40		59	1.85		38	41	9	100	159	220
LM-30UU	30	45		64	1.85		43	44.5	9.75	159	279	250
LM-40UU	40	60		80	2.1		57	60.5	9.75	219	409	585
LM-50UU	50	80		100	2.6		76.5	74	13	389	808	1580

※ UU has oil seals at the ends

LM-L Series Specifications (Lengthen)

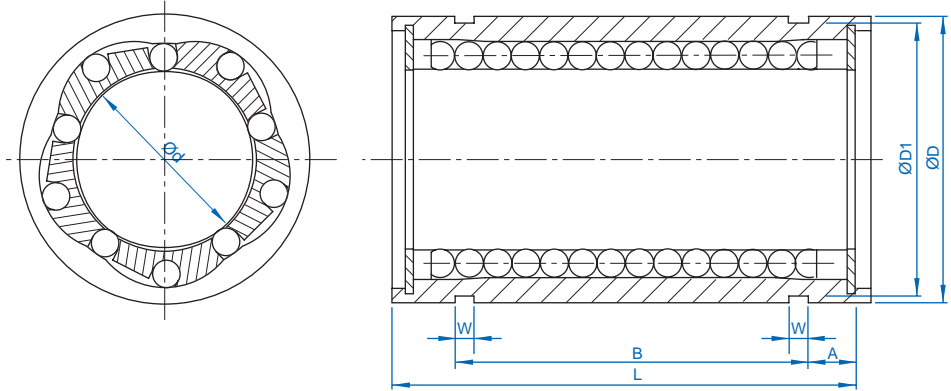

Unit : mm

Model No.	Dimension									Ca (kgf)	Coa (kgf)	Weight(g)
	d	D	D Tolerance (μm)	L	L Tolerance (μm)	W	D1	B	A			
LM-06LUU	6	12	0	35	0 -30	1.1	11.5	27	4	33	54	16
LM-08LUU	8	15	-13	45		1.1	14.3	35	5	44	80	31
LM-10LUU	10	19	0 -16	55		1.3	18	44	5.5	60	112	62
LM-12LUU	12	21		57		1.3	20	46	5.5	83	160	80
LM-16LUU	16	28		70		1.6	27	53	8.5	126	240	145
LM-20LUU	20	32	0 -19	80	1.6	30.5	61	9.5	143	280	180	
LM-25LUU	25	40		112	1.85	38	82	15	159	320	440	
LM-30LUU	30	45	0 -22	123	1.85	43	89	17	254	560	580	
LM-40LUU	40	60		151	2.1	57	121	15	350	820	1170	
LM-50LUU	50	80		192	2.6	76.5	148	22	620	1622	3100	

※UU has oil seals at the ends

ABOUT LINEAR BALL BEARING

1-1 Features of *TBI MOTION* Linear Ball Bearing

LF Series Specifications (Flange Type)

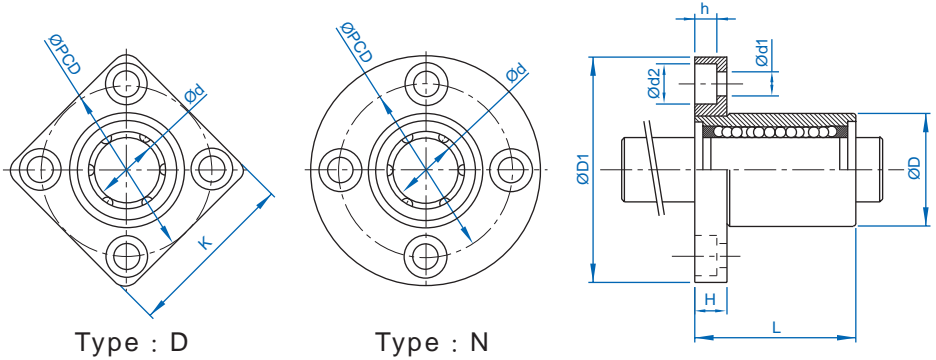

Unit : mm

Model No.	Dimension												Ca (kgf)	Coa (kgf)	Weight (g)
	d	D	D Tolerance (μm)	L	L Tolerance (μm)	D1	PCD	H	K	d1	d2	h			
LF-06UU	6	12	0	19	0 -20	28	20	5	22	3.5	6	3.1	21	27	8
LF-08UU	8	15	-11	24		32	24	5	25	3.5	6	3.1	28	40	16
LF-10UU	10	19	0 -13	29		40	29	6	30	4.5	7.5	4.1	38	56	30
LF-12UU	12	21		30		42	32	6	32	4.5	7.5	4.1	52	80	31.5
LF-16UU	16	28		37		48	38	6	37	4.5	7.5	4.1	79	120	69
LF-20UU	20	32	0 -16	42		54	43	8	42	5.5	9	5.1	90	140	87
LF-25UU	25	40		59	62	51	8	50	5.5	9	5.1	100	159	220	
LF-30UU	30	45		64	74	60	10	58	6.6	11	6.1	159	279	250	
LF-40UU	40	60	0 -19	80	0 -30	96	78	13	75	9	14	8.1	218	409	585
LF-50UU	50	80		100		116	98	13	92	9	14	8.1	389	808	1580

※UU has oil seals at the ends

LF-L Series Specifications (Flange Type with Lengthen Nut)

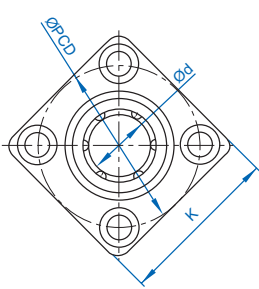

Type : D

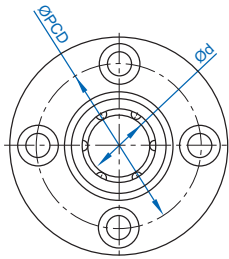

Type : N

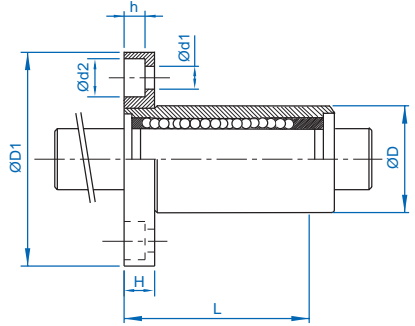

Unit : mm

ModelNo.	Dimension											Ca (kgf)	Coa (kgf)	Weight (g)	
	d	D	D Tolerance (μm)	L	L Tolerance (μm)	D1	PCD	H	K	d1	d2				h
LF-06LUU	6	12	0	35	0	28	20	5	22	3.5	6	3.1	33	54	16
LF-08LUU	8	15	-13	45		32	24	5	25	3.5	6	3.1	44	80	31
LF-10LUU	10	19	-16	55		40	29	6	30	4.5	7.5	4.1	60	112	62
LF-12LUU	12	21		57		42	32	6	32	4.5	7.5	4.1	83	160	80
LF-16LUU	16	28		70		48	38	6	37	4.5	7.5	4.1	126	240	145
LF-20LUU	20	32	0	80	54	43	8	42	5.5	9	5.1	143	280	180	
LF-25LUU	25	40		-19	112	62	51	8	50	5.5	9	5.1	159	320	440
LF-30LUU	30	45	0	123	74	60	10	58	6.6	11	6.1	254	560	580	
LF-40LUU	40	60		151	96	78	13	75	9	14	8.1	350	820	1170	
LF-50LUU	50	80		-22	192	116	98	13	92	9	14	8.1	620	1622	3100

※ UU has oil seals at the ends

ABOUT LINEAR BALL BEARING

1-1 Features of *TBI MOTION* Linear Ball Bearing

LU/LP Series Specifications (Aluminum Housing Type)

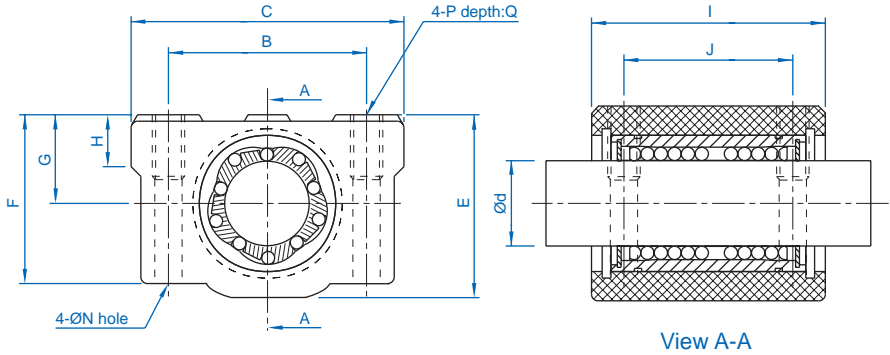

Unit : mm

Model No.	Dimension												Ca (kgf)	Coa (kgf)	Weight (g)
	d	B	C	E	F	G ±0.02	H	I	J	N	P	Q			
LU-08UU LP-08	8	24	34	22	18	11	6	30	18	3.4	M4	8	28	40	52
LU-10UU LP-10	10	28	40	26	21	13	8	35	21	4.3	M5	12	38	56	92
LU-12UU LP-12	12	30.5	42	29	25	15	8	36	26	4.3	M5	12	52	80	102
LU-16UU LP-16	16	36	50	38.5	32.5	19	9	44	34	4.3	M5	12	79	120	200
LU-20UU LP-20	20	40	54	41	35	21	11	50	40	5.2	M6	12	90	140	255
LU-25UU LP-25	25	54	76	51.5	42	26	12	67	50	7	M8	18	100	160	600
LU-30UU LP-30	30	58	78	59.5	49	30	15	72	58	7	M8	18	160	280	735
LU-40UU LP-40	40	80	102	78	62	40	20	90	60	8.7	M10	25	220	410	1590
LU-50UU LP-50	50	100	122	102	80	52	25	110	80	8.7	M10	25	390	810	3340

※ LP series does not include Linear ball bearing.

SF/WV Series Specifications (Shaft)

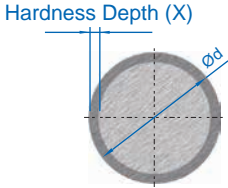

Material : S55C/SUJ2

Hardness : HRC 60 Up

Surface Roughness : Ra 0.15-0.35 μm

Shaft Straightness : approx. 0.1 mm/m

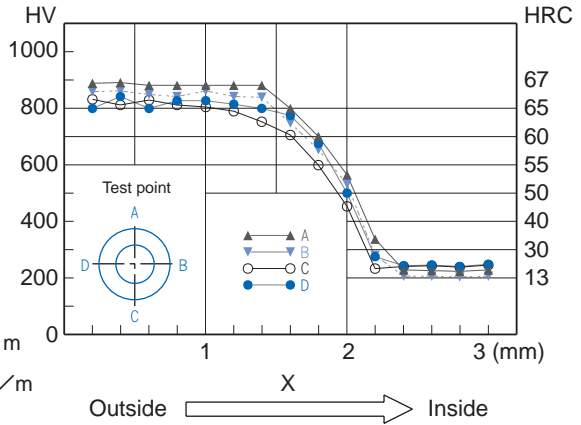

Unit : mm

Model No.	d	Hardness Depth (X)
SF-08 *	8	1.0
SF-10 *	10	1.0
SF-12 *	12	1.6
SF-16 *	16	1.6
SF-20 *	20	2.2
SF-25 *	25	2.2
SF-30 *	30	2.2
SF-32 *	32	2.2
SF-40 *	40	3.5
SF-50 *	50	3.5

※ With ★ can supply Chromium plated slide shaft (Model No. WV).

ABOUT LINEAR BALL BEARING

1-1 Features of *TBI MOTION* Linear Ball Bearing

SS Series Specifications (Shaft Support)

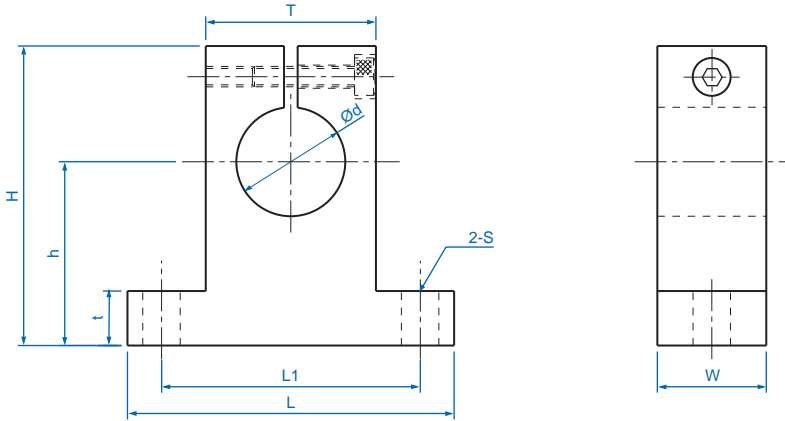

Unit : mm

Model No.	Dimension									Weight(g)
	d	h	L	W	H	t	T	L1	S	
SS-08	8	20	42	14	32.8	6	18	32	5.5	24
SS-10	10	20	42	14	32.8	6	18	32	5.5	24
SS-12	12	23	42	14	37.5	6	20	32	5.5	30
SS-16	16	27	48	16	44	8	25	38	5.5	40
SS-20	20	31	60	20	51	10	30	45	6.6	70
SS-25	25	35	70	24	60	12	38	56	6.6	130
SS-30	30	42	84	28	70	12	44	64	9	180
SS-40	40	60	114	36	96	15	60	90	11	420
SS-50	50	70	126	40	120	18	74	100	14	750

Support Unit of Ball Screw

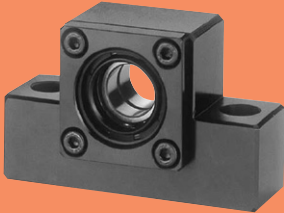

- 1-1 Features of TBI MOTION Support Unit of Ball Screw G02**
- 1-2 Assembling Steps of TBI MOTION Linear Ball Bearing G04**
- 1-3 Checking Geometric Accuracy G05**
- 1-4 Connect Ball Screw Motor..... G05**
 - BK Series (Fixed End) G06
 - BK Series (Fixed End) G08
 - BF Series (Floated End) G10
 - EK Series (Fixed End) G12
 - EK Series (Fixed End) G14
 - EF Series (Floated End) G16
 - FK Series (Fixed End)..... G18
 - FK Series (Fixed End)..... G20
 - FF Series (Floated End)..... G22

ABOUT SUPPORT UNIT OF BALL

1-1 Features of *TBI MOTION* Support Unit of Ball Screw

BK/EK/FK/BF/EF/FF

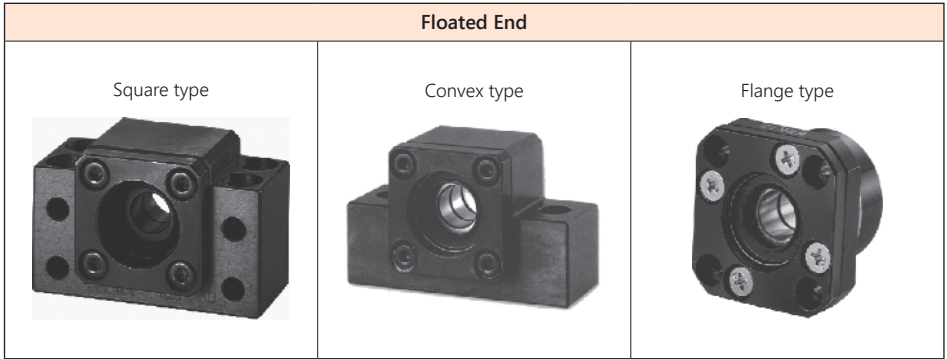

Surface Treatment : Black Oxidation

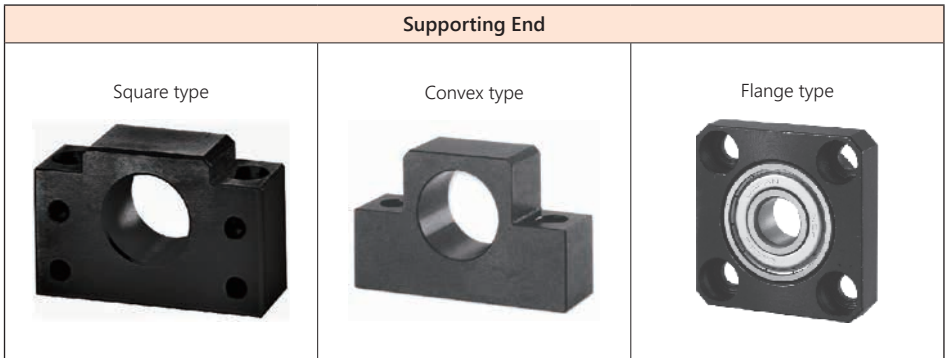

Surface Treatment : Black Oxidation

Table 1.1.1 Types of Support and Suggested Diameter of Ball Screw

FixedEndModel			SimpleEndModel			SuggestedDiameter
FlangeType	SquareType		FlangeType	SquareType		
-	EK-6	-	FF-6	EF-6	-	Ø4,Ø6
FK-8	EK-8	-	FF-8	EF-8	-	Ø8,Ø10,Ø12
FK-10	EK-10	BK-10	FF-10	EF-10	BF-10	Ø12,Ø14,Ø15
FK-12	EK-12	BK-12	FF-12	EF-12	BF-12	Ø14,Ø15,Ø16
FK-15	EK-15	BK-15	FF-15	EF-15	BF-15	Ø18,Ø20
-	-	BK-17	-	-	BF-17	Ø20,Ø25
FK-20	EK-20	BK-20	FF-20	EF-20	BF-20	Ø25,Ø28
FK-25	EK-25	BK-25	FF-25	EF-25	BF-25	Ø32,Ø36
FK-30	-	BK-30	FF-30	-	BF-30	Ø36,Ø40
-	-	BK-35	-	-	BF-35	Ø40,Ø45,Ø50
-	-	BK-40	-	-	BF-40	Ø50,Ø55

Table 1.1.2 Function

Fixed End				Simple End			
Support Model	Bearing Model	Axial		Support Model	Bearing Model	Radial	
		Ca (kgf)	K kgf/μm			Ca (kgf)	Coa (kgf)
EK-6	706ATYDF	273	2.9	EF-6, FF-6	606ZZ	231	88
EK-8, FK-8	708ATYDF	450	5.4	EF-8, FF-8	606ZZ	231	88
BK-10, EK-10, FK-10	7000ATYDF	620	9.6	BF-10, EF-10, FF-10	608ZZ	335	142
BK-12, EK-12, FK-12	7001ATYDF	679	10.6	BF-12, EF-12, FF-12	6000ZZ	465	200
BK-15, EK-15, FK-15	7002ATYDF	775	11.5	BF-15, EF-15, FF-15	6002ZZ	570	289
BK-17	7203ATYDF	1397	12.7	BF-17	6203ZZ	979	469
BK-20	7004ATYDF	1295	14.2	BF-20	6004ZZ	958	515
EK-20, FK-20	7204ATYDF	1820	15.8	EF-20, FF-20	6204ZZ	1300	702
BK-25, EK-25, FK-25	7205ATYDF	2060	19.4	BF-25, EF-25, FF25	6205ZZ	1430	800
BK-30, FK-30	7206ATYDF	2856	19.8	BF-30, FF30	6206ZZ	1989	1152
BK-35	7207ATYDF	3794	26.0	BF-35	6207ZZ	2621	1560
BK-40	7208ATYDF	4498	27.5	BF-40	6208ZZ	2968	1815

※When the nominal diameter of ball screw is Ø6 and use EK06 or EF06, ball screw has to be precision ground type.

ABOUT SUPPORT UNIT OF BALL

1-1 Assembling Steps of *TBI MOTION* Linear Ball Bearing

■ 1-1 Installing Ball Screw with Support Units

(1) Assemble the fixed end Support Unit with the screw shaft.

※ Do not disassemble the Support Unit.

※ When assembling the screw shaft to the Support Unit, make sure that the dimension between machine ends and bearing are matched.

(2) After inserting the fixed end Support Unit, secure the lock nut by using the fasten set piece and the hexagonal socket-head set screws.

※ Please contact TBI for special condition of mounting methods.

(3) Attach the floated end bearing to the screw shaft and secure the bearing with the C-ring.

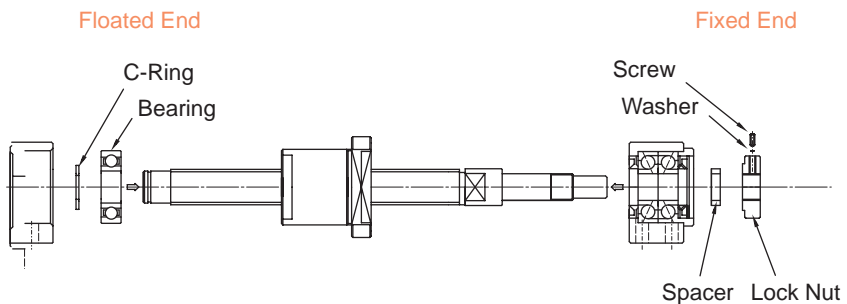

Fig 1.1.1

■ 1-2 Assemble the Nut Bracket

(1) Fix the ball screw to the bracket(temporarily).

(2) Assemble the fixed end Support unit with bearing.

(3) Ensure the parallelism between reference surface(linear guide) and ball screw, then fix both end and floated end.

(4) Move the table toward fixed and floated end to ensure the smoothness of the ball screw then fasten it to the bracket.

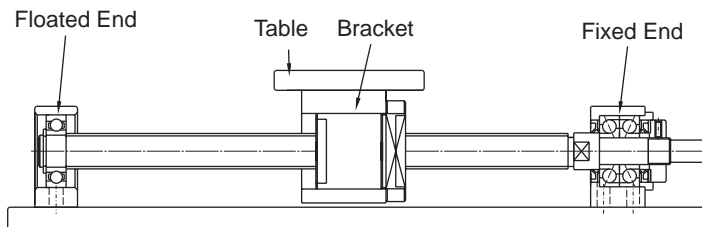

Fig 1.2.1

■ 1-3 Checking Geometric Accuracy

(1) Measure the runout of fixed side support unit and the axial backlash of support side support unit.

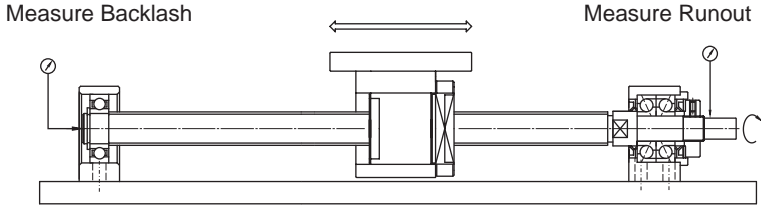

Fig 1.3.1

■ 1-4 Connect Ball Screw Motor

- (1) Mount the motor bracket to the base.
- (2) Connect the motor and the ball screw with a coupling (Careful with accuracy while mounting)
- (3) Completed run test.

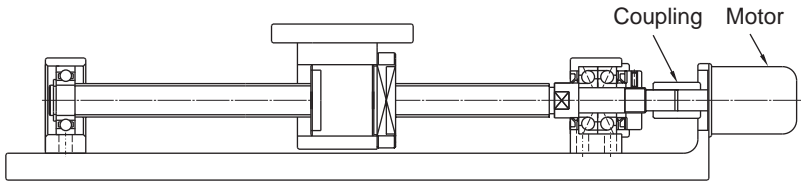
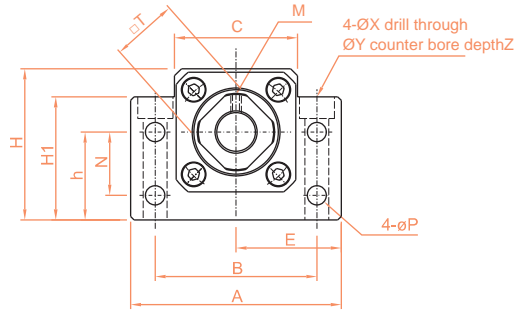

Fig 1.4.1

ABOUT SUPPORT UNIT OF BALL

1-1 Features of *TBI MOTION* Support Unit of Ball Screw

BK Series (Fixed End)



ModelNo.	D1	A	B	C	C1	C2	E	H1	h	H
							±0.02		±0.02	
BK-10	10	60	46	34	13	6	30	32.5	22	39
BK-12	12	60	46	34	13	6	30	32.5	25	43
BK-15	15	70	54	40	15	6	35	38	28	48
BK-17	17	86	68	50	19	8	43	55	39	64
BK-20	20	88	70	52	19	8	44	50	34	60

Suggest Dimension of End Machining

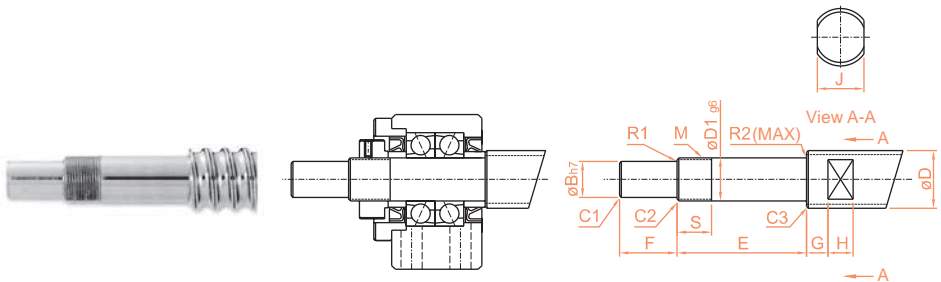

ModelNo.	Diameter	D1	B	E	F	M
BK-10	ø12,ø14,ø15	10	8	39	15	M10×1
BK-12	ø14,ø15,ø16,ø18	12	10	39	15	M12×1
BK-15	ø18,ø20	15	12	40	20	M15×1
BK-17	ø20,ø25	17	15	53	23	M17×1
BK-20	ø25,ø28	20	17	53	25	M20×1

SCREW

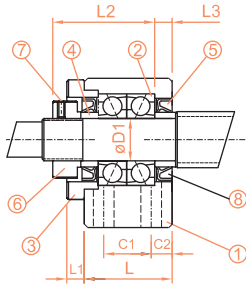

Code	Items	pcs
1	Housing	1PCS
2	Bearing	1SET
3	Lid	1PCS
4	Spacer	2PCS
5	Seal	2PCS
6	Lock Nut	1PCS
7	Screw with Washer	1PCS

Unit : mm

L	L1	L2	L3	T	P	N	M	X	Y	Z	Bearing Model
25	5	29	5	16	5.5	15	M3	6.6	11	5	7000ATYDFC8P5
25	5	29	5	19	5.5	18	M3	6.6	11	1.5	7001ATYDFC8P5
27	6	32	6	22	5.5	18	M3	6.6	11	6.5	7002ATYDFC8P5
35	9	44	7	24	6.6	28	M4	9	14	8.5	7203ATYDFC8P5
35	8	43	8	30	6.6	22	M4	9	14	8.5	7004ATYDFC8P5

Tolerance

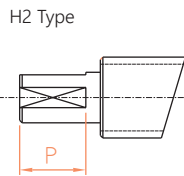
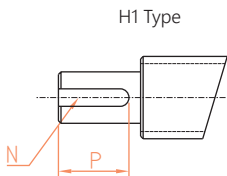

Dimension(mm)		unit ^h _{0.001}
Above	Under	h
6	10	-2 -15
10	18	-3 -18
18	24	-3 -21

S	J	G	H	Chamfering			Circular Radius		H1 Keyway(W×D×L)		H2		Model BK
				C1	C2	C3	R1	R2	N	P	R	P	
16	10	5	7	0.5	0.5	0.5	0.3	0.6	2×1.2	11	7.5	11	BK-10
14	13	6	8	0.5	0.5	0.5	0.3	0.6	3×1.8	12	9.5	12	BK-12
12	16	6	9	0.5	0.5	0.5	0.3	0.6	4×2.5	16	11.3	16	BK-15
17	18	7	10	0.5	0.5	0.5	0.3	0.6	5×3.0	21	14.3	21	BK-17
15	21	8	11	0.5	0.5	0.5	0.5	0.6	5×3.0	21	16	21	BK-20

ABOUT SUPPORT UNIT OF BALL

1-1 Features of *TBI MOTION* Support Unit of Ball Screw

BK Series (Fixed End)

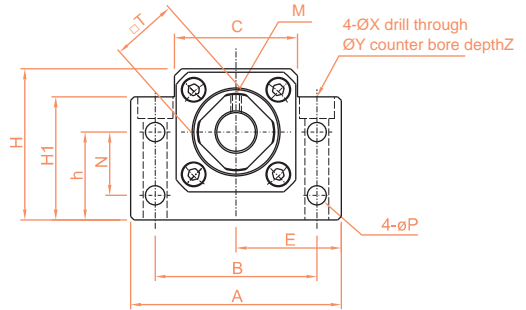

ModelNo.	D1	A	B	C	C1	C2	E	H1	h	H
							± 0.02		± 0.02	
BK-25	25	106	85	64	22	10	53	70	48	80
BK-30	30	128	102	76	23	11	64	78	51	89
BK-35	35	140	114	88	26	12	70	79	52	96
BK-40	40	160	130	100	33	14	80	90	60	110

Suggest Dimension of End Machining

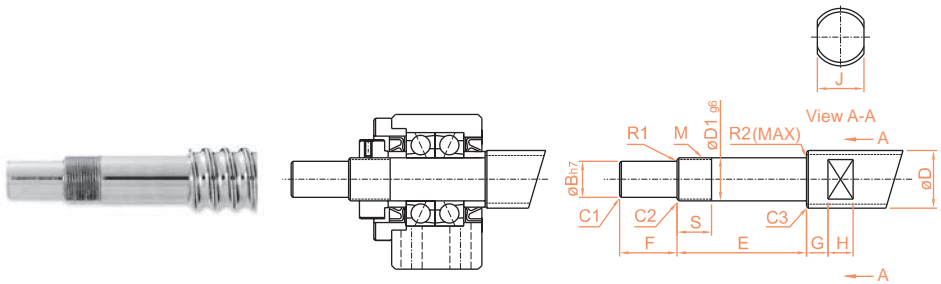

ModelNo.	Diameter	D1	B	E	F	M
BK-25	Ø32,Ø36	25	20	65	30	M25×1.5
BK-30	Ø36,Ø40	30	25	72	38	M30×1.5
BK-35	Ø40,Ø45,Ø50	35	30	83	45	M35×1.5
BK-40	Ø50,Ø55	40	35	98	50	M40×1.5

SCREW

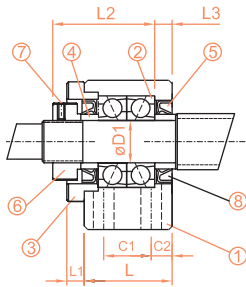

Code	Items	pcs
1	Housing	1PCS
2	Bearing	1SET
3	Lid	1PCS
4	Spacer	2PCS
5	Seal	2PCS
6	Lock Nut	1PCS
7	Screw with Washer	1PCS

Unit : mm

L	L1	L2	L3	T	P	N	M	X	Y	Z	Bearing Model
42	12	54	9	35	9	33	M5	11	17.5	11	7205ATYDFC8P5
45	14	61	9	40	11	33	M6	14	20	13	7206ATYDFC8P5
50	14	67	12	50	11	35	M8	14	20	13	7207ATYDFC8P5
61	18	76	15	50	14	37	M8	18	26	17.5	7208ATYDFC8P5

G

Support Unit of Ball Screw

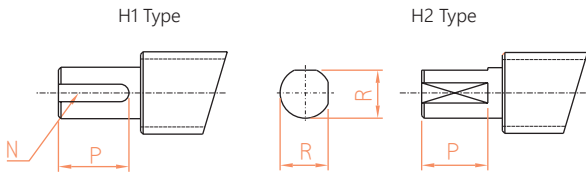

Tolerance

Dimension(mm)		unit $\frac{h}{0.001}$
Above	Under	h
18	30	-3 -21
30	50	-4 -25

S	J	G	H	Chamfering			Circular Radius		H1 Keyway(W×D×L)		H2		Model BK
				C1	C2	C3	R1	R2	N	P	R	P	
18	27	10	13	0.5	0.7	1.0	0.5	0.6	6×3.5	25	19	25	BK-25
25	32	10	15	0.5	0.7	1.0	0.5	1.0	8×4.0	32	23.5	32	BK-30
28	36	12	15	0.5	1.0	1.0	0.5	1.0	8×4.0	40	28.5	40	BK-35
35	41	14	19	0.5	1.0	1.0	0.5	1.0	10×5.0	45	33	45	BK-40

ABOUT SUPPORT UNIT OF BALL

1-1 Features of *TBI MOTION* Support Unit of Ball Screw

BF Series (Floated End)

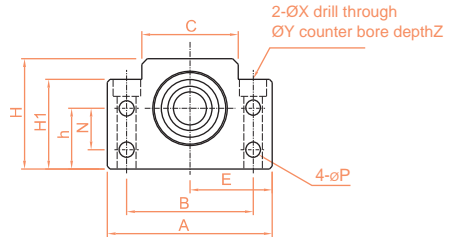

ModelNo.	D1	A	B	C	E	H1	h	H
					±0.02		±0.02	
BF-10	8	60	46	34	30	32.5	22	39
BF-12	10	60	46	34	30	32.5	25	43
BF-15	15	70	54	40	35	38	28	48
BF-17	17	86	68	50	43	55	39	64
BF-20	20	88	70	52	44	50	34	60
BF-25	25	106	85	64	53	70	48	80
BF-30	30	128	102	76	64	78	51	89
BF-35	35	140	114	88	70	79	52	96
BF-40	40	160	130	100	80	90	60	110

Suggest Dimension of End Machining

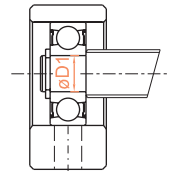

ModelNo.	Diameter	D1	E
BF-10	Ø12,Ø14,Ø15	8	10
BF-12	Ø14,Ø15,Ø16	10	11
BF-15	Ø18,Ø20	15	13
BF-17	Ø20,Ø25	17	16
BF-20	Ø25,Ø28	20	16
BF-25	Ø32,Ø36	25	20
BF-30	Ø36,Ø40	30	21
BF-35	Ø40,Ø45,Ø50	35	22
BF-40	Ø50,Ø55	40	23

SCREW

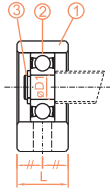

Code	Items	pcs
1	Housing	1PCS
2	Bearing	1PCS
3	C-Ring	1PCS

Unit : mm

L	N	P	X	Y	Z	C-Ring	Bearing Model
20	15	5.5	6.6	11	5	C8	608ZZ
20	18	5.5	6.6	11	1.5	C10	6000ZZ
20	18	5.5	6.6	11	6.5	C15	6002ZZ
23	28	6.6	9	14	8.5	C17	6203ZZ
26	22	6.6	9	14	8.5	C20	6004ZZ
30	33	9	11	17.5	11	C25	6205ZZ
32	33	11	14	20	13	C30	6206ZZ
32	35	11	14	20	13	C35	6207ZZ
37	37	14	18	26	17.5	C40	6208ZZ

G

Support Unit of Ball Screw

Tolerance

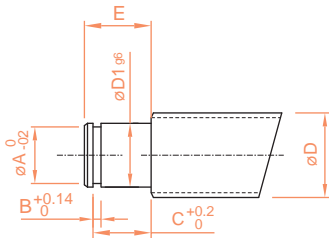

Dimension(mm)		unit $h_{0.001}$
Above	Under	h
6	10	-2 -15
10	18	-3 -18
18	30	-3 -21
30	50	-4 -25

C-Ring			Model BF
A	B	C	
7.6	0.9	7.9	BF-10
9.6	1.15	9.15	BF-12
14.3	1.15	10.15	BF-15
16.2	1.15	13.15	BF-17
19.0	1.35	13.35	BF-20
23.9	1.35	16.35	BF-25
28.6	1.75	17.75	BF-30
33.0	1.75	18.75	BF-35
38.0	1.95	19.95	BF-40

ABOUT SUPPORT UNIT OF BALL

1-1 Features of *TBI MOTION* Support Unit of Ball Screw

EK Series (Fixed End)

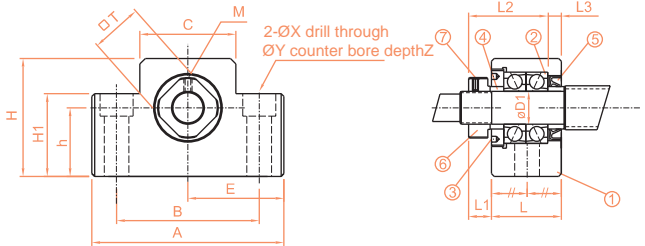
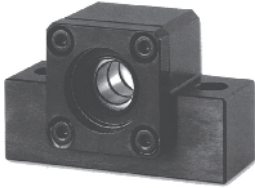

ModelNo.	D1	A	B	C	E	H1	h
					±0.02		±0.02
EK-6	6	42	30	18	21	20	13
EK-8	8	52	38	25	26	26	17
EK-10	10	70	52	36	35	24	25
EK-12	12	70	52	36	35	24	25
EK-15	15	80	60	41	40	25	30

Suggest Dimension of End Machining

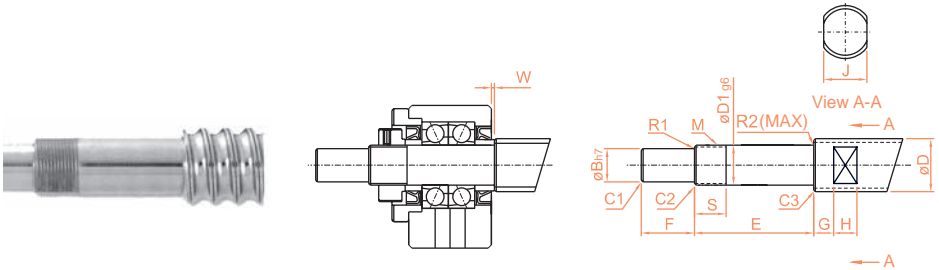

ModelNo.	Diameter	D1	B	E	F	M
EK-6	Ø6,Ø8	6	4	30	8	M6×0.75
EK-8	Ø10,Ø12	8	6	35	9	M8×1
EK-10	Ø12,Ø14,Ø15	10	8	36	15	M10×1
EK-12	Ø14,Ø15,Ø16	12	10	36	15	M12×1
EK-15	Ø18,Ø20	15	12	49	20	M15×1

※ When the nominal diameter of ball screw is Ø6 and use EK06 or EF06, ball screw has to be precision ground type.

SCREW

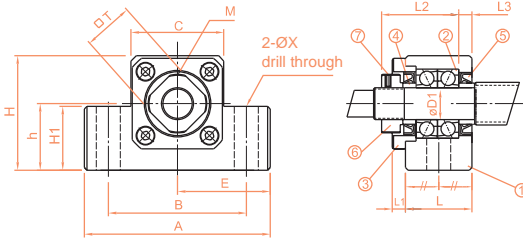

EK10-15

Code	Items	pcs
1	Housing	1PCS
2	Bearing	1SET
3	Lid	1PCS
4	Spacer	2PCS
5	Seal	2PCS
6	Lock Nut	1PCS
7	Screw with Washer	1PCS

Unit : mm

H	L	L1	L2	L3	M	X	Y	Z	T	Bearing Model
25	20	5.5	22	3.5	M3	5.5	9.5	11	12	706ATYDFC7P5
32	23	7	26	4	M3	6.6	11	12	14	708ATYDFC8P5
43	24	6	29.5	6	M3	9	-	-	16	7000ATYDFC8P5
43	24	6	29.5	6	M3	9	-	-	19	7001ATYDFC8P5
49	25	6	36	5	M3	11	-	-	22	7002ATYDFC8P5

Tolerance

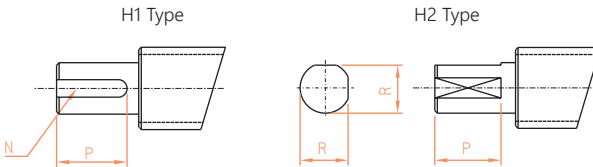

Dimension(mm)		unit $\frac{h}{0.001}$
Above	Under	h
6	10	-2 -15
10	18	-3 -18
18	24	-3 -21

S	J	G	H	Chamfering			Circular Radius		H1 Keyway(W×D×L)		H2		W	Model EK
				C1	C2	C3	R1	R2	N	P	R	P		
10	5	4	4	0.3	0.3	0.3	0.3	0.6	-	-	3.7	6	1.5	EK-6
10	8	5	5	0.3	0.3	0.3	0.3	0.6	-	-	5.6	7	1.5	EK-8
11	10	5	7	0.5	0.5	0.5	0.3	0.6	2×1.2	11	7.5	11	-0.5	EK-10
11	13	6	8	0.5	0.5	0.5	0.3	0.6	3×1.8	12	9.5	12	-0.5	EK-12
13	16	6	9	0.5	0.5	0.5	0.3	0.6	4×2.5	16	11.3	16	5.0	EK-15

ABOUT SUPPORT UNIT OF BALL

1-1 Features of *TBI MOTION* Support Unit of Ball Screw

EK Series (Fixed End)

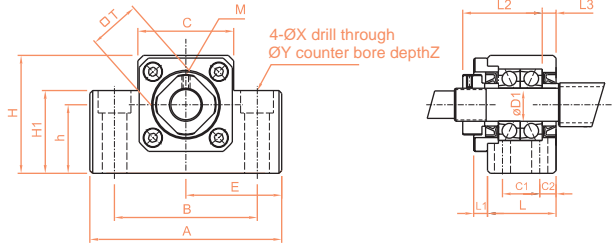
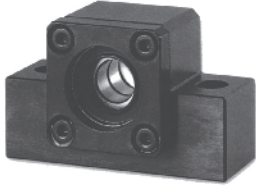

EK-20S

ModelNo.	D1	A	B	C	E	H1	h
					±0.02		±0.02
EK-20	20	95	75	56	47.5	25	30
EK-25	25	105	85	66	52.5	25	35

Suggest Dimension of End Machining

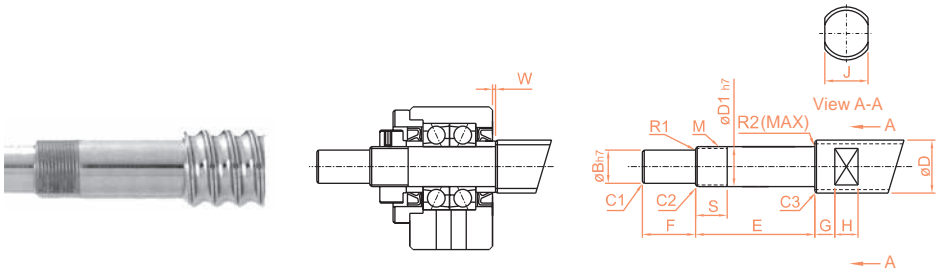

ModelNo.	Diameter	D1	B	E	F	M
EK-20	Ø25,Ø28,Ø32	20	17	64	25	M20×1
EK-25	Ø32,Ø36	25	20	65	30	M25×1.5

SCREW

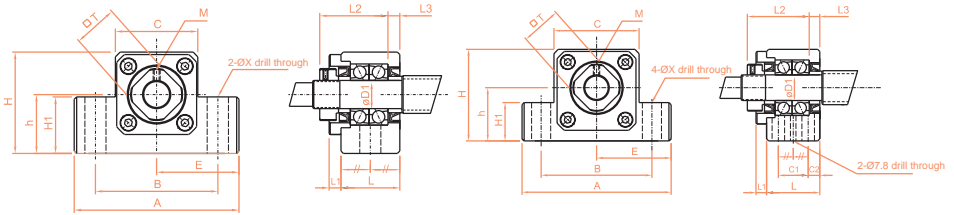

EK-20

EK-25

Unit : mm

C2	C1	H	L	L1	L2	L3	M	X	Y	Z	T	Bearing Model
-	-	58	42	10	50	10	M4	11	-	-	30	7204ATYDFC8P5
9	30	68	48	13	60	14	M5	11	-	-	35	7205ATYDFC8P5

Tolerance

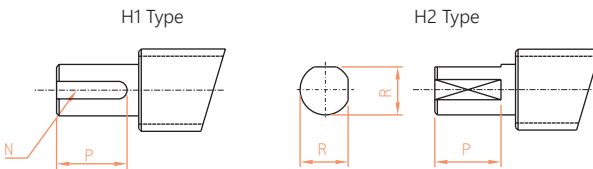

Dimension(mm)		unit $\frac{h}{0.001}$
Above	Under	h
6	10	-2 -15
10	18	-3 -18
18	24	-3 -21

S	J	G	H	Chamfering			Circular Radius		H1 Keyway(W×D×L)		H2		W	Model EK
				C1	C2	C3	R1	R2	N	P	R	P		
17	21	8	11	0.5	0.5	0.5	0.5	0.6	5×3.0	21	16	21	1.0	EK-20
18	27	10	13	0.5	0.7	1.0	0.5	0.6	6×3.5	25	19	25	1.0	EK-25

G

Support Unit of Ball Screw

ABOUT SUPPORT UNIT OF BALL

1-1 Features of *TBI MOTION* Support Unit of Ball Screw

EF Series (Floated End)

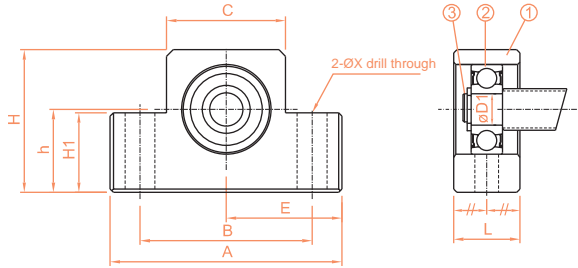

EF10-15 ; EF20-25

ModelNo.	D1	A	B	C	E	H1	h
					±0.02		±0.02
EF-6	6	42	30	18	21	20	13
EF-8	6	52	38	25	26	26	17
EF-10	8	70	52	36	35	24	25
EF-12	10	70	52	36	35	24	25
EF-15	15	80	60	41	40	25	30
EF-20	20	95	75	56	47.5	25	30
EF-25	25	105	85	66	52.5	25	35

Suggest Dimension of End Machining

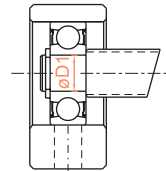

ModelNo.	Diameter	D1	E
EF-6	Ø6,Ø8	6	9
EF-8	Ø10,Ø12	6	9
EF-10	Ø12,Ø14,Ø15	8	10
EF-12	Ø14,Ø15,Ø16	10	11
EF-15	Ø18,Ø20	15	13
EF-20	Ø25,Ø28	20	19
EF-25	Ø32,Ø36	25	20

※ When the nominal diameter of ball screw is Ø6 and use EK06 or EF06, ball screw has to be precision ground type.

SCREW

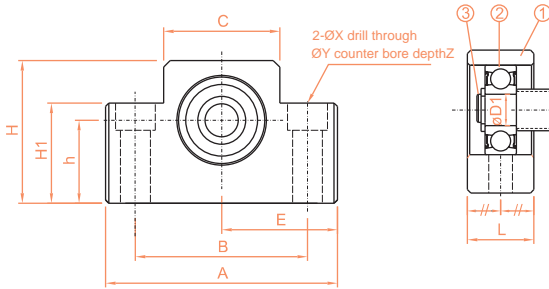

EF6-8

Code	Items	pcs
1	Housing	1PCS
2	Bearing	1PCS
3	C-Ring	1PCS

Unit : mm

H	L	X	Y	Z	C-Ring	Bearing Model
25	12	5.5	9.5	11	C6	606ZZ
32	14	6.6	11	12	C6	606ZZ
43	20	9	-	-	C8	608ZZ
43	20	9	-	-	C10	6000ZZ
49	20	9	-	-	C15	6002ZZ
58	26	11	-	-	C20	6204ZZ
68	30	-	11	-	C25	6205ZZ

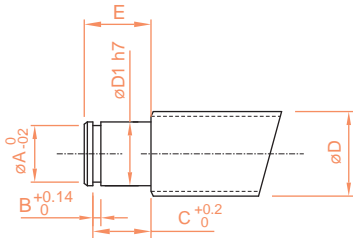

Tolerance

Dimension(mm)		unit ^h _{0.001}
Above	Under	h
6	10	-2 -15
10	18	-3 -18
18	24	-3 -21

C-Ring			Model EF
A	B	C	
5.7	0.8	6.8	EF-6
5.7	0.8	6.8	EF-8
7.6	0.9	7.9	EF-10
9.6	1.15	9.15	EF-12
14.3	1.15	10.15	EF-15
19	1.35	15.35	EF-20
23.9	1.35	16.35	EF-25

G

Support Unit of Ball Screw

ABOUT SUPPORT UNIT OF BALL

1-1 Features of *TBI MOTION* Support Unit of Ball Screw

FK Series (Fixed End)



Solution A

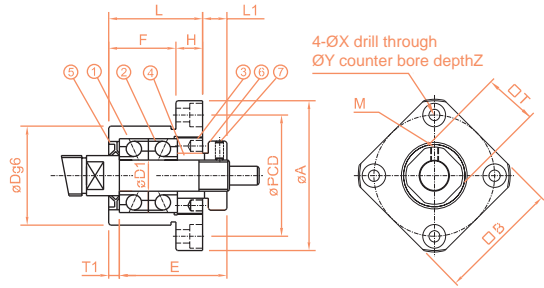

ModelNo.	D1	A	F	L	E	Dg6	H	PCD
FK-8	8	43	14	23	26	28	9	35

Suggest Dimension of End Machining

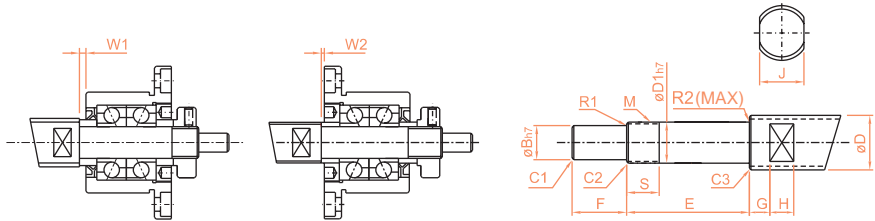

ModelNo.	Diameter	D1	B	E	F	M
FK-8	$\phi 10, \phi 12$	8	6	35	9	M8×1

SCREW

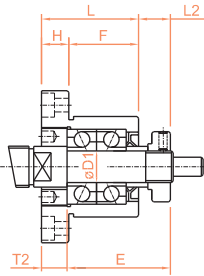

D	g6
28	-0.007 -0.020

Code	Items	pcs
1	Housing	1PCS
2	Bearing	1SET
3	Lid	1PCS
4	Spacer	2PCS
5	Seal	2PCS
6	Lock Nut	1PCS
7	Screw with Washer	1PCS

Solution B

Unit : mm

M	B	L1	T1	L2	T2	X	Y	Z	T	Bearing Model
M3	35	7	4	8	5	3.4	6.5	4	14	708ATYDFC8P5

H1 type

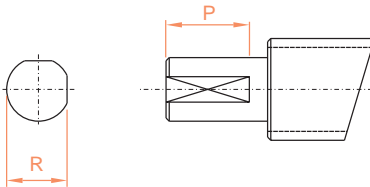

Tolerance

Dimension(mm)		unit ^h 0.001
Above	Under	h
6	10	-2 -15

S	Chamfering			Circular Radius		H1		W1	W2	Model FK
	C1	C2	C3	R1	R2	R	P			
15	0.5	0.5	0.5	0.3	0.6	5.6	7	1.5	0.5	FK-8

G

Support Unit of Ball Screw

ABOUT SUPPORT UNIT OF BALL

1-1 Features of *TBI MOTION* Support Unit of Ball Screw

FK Series (Fixed End)

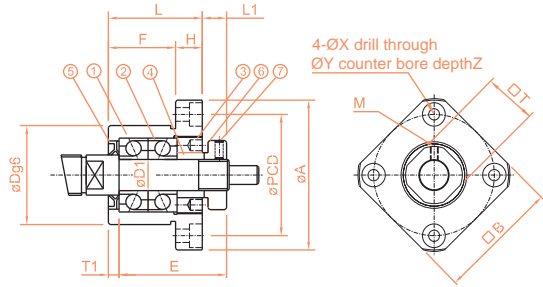

Solution B

Solution A

ModelNo.	D1	A	F	L	E	Dg6	H	PCD
FK-10	10	52	17	27	29.5	34	10	42
FK-12	12	54	17	27	29.5	36	10	44
FK-15	15	63	17	32	36	40	15	50
FK-20	20	85	30	52	50	57	22	70
FK-25	25	98	30	57	60	63	27	80
FK-30	30	117	32	62	61	75	30	95

Suggest Dimension of End Machining

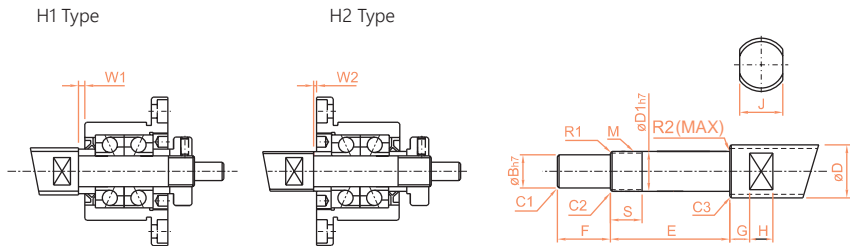

ModelNo.	Diameter	D1	B	E	F	M
FK-10	$\phi 12, \phi 14, \phi 15$	10	8	36	15	M10 \times 1
FK-12	$\phi 14, \phi 15, \phi 16$	12	10	36	15	M12 \times 1
FK-15	$\phi 18, \phi 20$	15	12	49	20	M15 \times 1
FK-20	$\phi 25, \phi 28$	20	17	64	25	M20 \times 1
FK-25	$\phi 32, \phi 36$	25	20	76	30	M25 \times 1.5
FK-30	$\phi 40, \phi 50$	30	25	72	38	M30 \times 1.5

SCREW

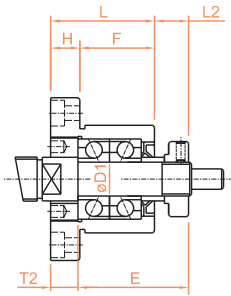

Solution B

D	g6
34	-0.009 -0.025
36	-0.009 -0.025
40	-0.009 -0.025
57	-0.010 -0.029
63	-0.010 -0.029
75	-0.010 -0.029

Code	Items	pcs
1	Housing	1PCS
2	Bearing	1SET
3	Lid	1PCS
4	Spacer	2PCS
5	Seal	2PCS
6	Lock Nut	1PCS
7	Screw with Washer	1PCS

Unit : mm

M	B	L1	T1	L2	T2	X	Y	Z	T	Bearing Model
M3	42	7.5	5	8.5	6	4.5	8	4	16	7000ATYDFC8P5
M3	44	7.5	5	8.5	6	4.5	8	4	19	7001ATYDFC8P5
M3	52	10	6	12	8	5.5	9.5	6	22	7002ATYDFC8P5
M4	68	8	10	12	14	6.6	11	10	30	7204ATYDFC8P5
M5	79	13	10	20	17	9	15	13	35	7205ATYDFC8P5
M6	93	14	12	17	18	11	17.5	15	40	7206ATYDFC8P5

H1 Type

H2 Type

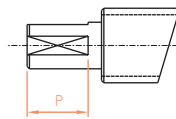
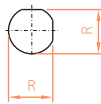
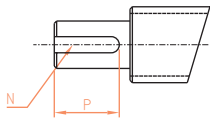

Tolerance

Dimension(mm)		unit ^h _{0.001}
Above	Under	h
6	10	-2 -15
10	18	-3 -18
18	30	-3 -21

S	J	G	H	Chamfering			Circular Radius		H1		H2		W1	W2	Model FK
				C1	C2	C3	R1	R2	N	P	R	P			
11	10	5	7	0.5	0.5	0.5	0.3	0.6	2×1.2	11	7.5	11	0.5	0.5	FK-10
11	13	6	8	0.5	0.5	0.5	0.3	0.6	3×1.8	12	9.5	12	0.5	0.5	FK-12
13	16	6	9	0.5	0.5	0.5	0.3	0.6	4×2.5	16	11.6	16	4	2	FK-15
17	21	8	11	0.5	0.5	0.5	0.5	0.6	5×3.0	21	16	21	1	-3	FK-20
20	27	10	13	0.5	0.5	0.5	0.5	0.6	6×3.5	25	19	25	5	-2	FK-25
25	32	10	15	0.5	0.5	0.5	0.5	0.6	8×4	32	23.5	32	-3	-6	FK-30

ABOUT SUPPORT UNIT OF BALL

1-1 Features of *TBI MOTION* Support Unit of Ball Screw

FF Series (Floated End)

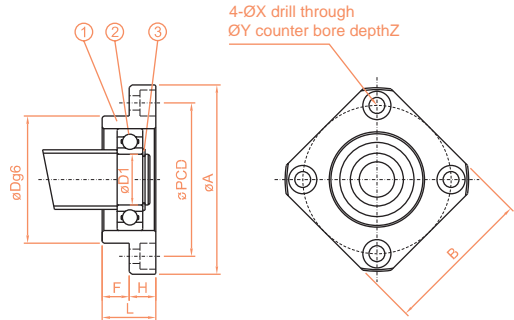

ModelNo.	D1	L	H	F	Dg6	A
FF-6	6	10	6	4	22	36
FF-10	8	12	7	5	28	43
FF-12	10	15	7	8	34	52
FF-15	15	17	9	8	40	63
FF-20	20	20	11	9	57	85
FF-25	25	24	14	10	63	98
FF-30	30	27	18	9	75	117

Suggest Dimension of End Machining

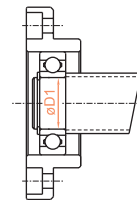

ModelNo.	Diameter	D1	E
FF-6	$\phi 10, \phi 12$	6	9
FF-10	$\phi 12, \phi 14, \phi 15$	8	10
FF-12	$\phi 14, \phi 15, \phi 16$	10	11
FF-15	$\phi 18, \phi 20$	15	13
FF-20	$\phi 25, \phi 28$	20	19
FF-25	$\phi 32, \phi 36$	25	20
FF-30	$\phi 40, \phi 50$	30	21

SCREW

D	g6
22	-0.007 -0.020
28	-0.007 -0.020
34	-0.009 -0.025
40	-0.009 -0.025
57	-0.010 -0.029
63	-0.010 -0.029
75	-0.010 -0.029

Code	Items	pcs
1	Housing	1PCS
2	Bearing	1PCS
3	C-Ring	1PCS

Unit : mm

PCD	B	X	Y	Z	C-Ring	Bearing Model
28	28	3.4	6.5	4	C6	606ZZ
35	35	3.4	6.5	4	C8	608ZZ
42	42	4.5	8	4	C10	6000ZZ
50	52	5.5	9.5	5.5	C15	6002ZZ
70	68	6.6	11	6.5	C20	6204ZZ
80	79	9	14	8.5	C25	6205ZZ
95	93	11	17.5	11	C30	6206ZZ

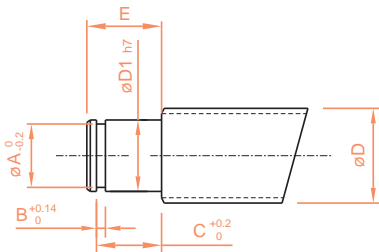

Tolerance

Dimension(mm)		unit ^h _{0.001}
Above	Under	h
6	10	-2 -15
10	18	-3 -18
18	30	-3 -21

C-Ring			Model FF
A	B	C	
5.7	0.8	6.8	FF-6
7.6	0.9	7.9	FF-10
9.6	1.15	9.15	FF-12
14.3	1.15	10.15	FF-15
19	1.35	15.35	FF-20
23.9	1.35	16.35	FF-25
28.6	1.75	17.75	FF-30

G

Support Unit of Ball Screw

Memo

A large area of horizontal dashed lines for writing a memo.

G

Support Unit of Ball Screw

Coupling



1-1 Features of TBI MOTION Coupling.....H02
SRJ SpecificationsH02
Function.....H03

ABOUT COUPLING

1-1 Features of *TBI MOTION* Coupling

SRJ Specifications

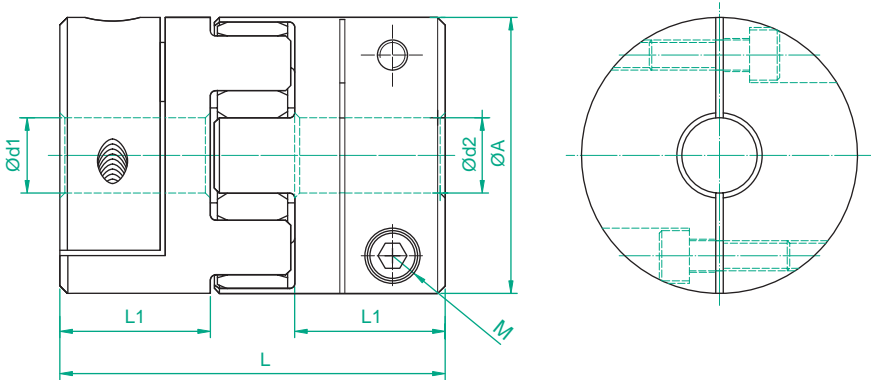

Unit : mm

ModelNo.	A	L	L1	dmax	(H8)d1xd2		M
					d1	d2	
SRJ-20C	20	30	10	8	5,6,6.35,7,8		M3
SRJ-30C	30	35	11	14	6,6.35,8,9,9.5,10,11,12,14		M4
SRJ-40C	40	66	25	20	10,11,12,14,15,16,18,19,20		M5
SRJ-55C	55	78	30	25	15,16,18,19,20,22,24,25		M6
SRJ-65C	65	90	35	35	15,16,18,19,20,22,24,25,28,30,32,35		M8

- ※ Specifications Number : SRJ-AC-d1xd2
- ※ Material : Aluminum Alloy
- ※ Buffer Material : Engineering Class Plastic

Function



ModelNo.	Rate Torque (N · m)	Max Torque (N · m)	Max Rotational Spring Rigidity (min-1)	Static Torsion Spring Rigidity (N · m/rad)	Dynamic Torsion Spring Rigidity (N · m/rad)
SRJ-20C	5	10	15200	51.0	151
SRJ-30C	12.5	25	10200	170.9	505
SRJ-40C	17	34	7600	857.5	2571
SRJ-55C	60	120	5600	2060	6163
SRJ-65C	160	320	4700	3430	10291

ModelNo.	Weight (g)		Mass Moment of Inertia J (kg·m ²)		Radial (mm)	Angular (°)	Axial (mm)
	each hub	spider	each hub	spider			
SRJ-20C	8.5	1.7	0.46×10 ⁻³	0.073×10 ⁻³	0.10	1.0	0.8
SRJ-30C	18	4.2	2.5×10 ⁻³	0.45×10 ⁻³	0.15	1.0	1
SRJ-40C	64	6.5	20.1×10 ⁻³	1.44×10 ⁻³	0.15	1.0	1.2
SRJ-55C	130	17.4	50.5×10 ⁻³	7.3×10 ⁻³	0.2	1.0	1.4
SRJ-65C	250	28.6	200.1×10 ⁻³	16.3×10 ⁻³	0.2	1.0	1.5

APPENDIX

TBI MOTION Linear Guideway Inquiry Form

APPENDIX

Customer :		Date :	
TEL :	Email :	Confirm By :	
Machine Type :		Drawing No. :	
Axis	<input type="checkbox"/> X <input type="checkbox"/> Y <input type="checkbox"/> Z <input type="checkbox"/> Other ()		
Install Position			
Model No.			
No.of Rail Per Axis	<input type="checkbox"/> 1 <input type="checkbox"/> 2 <input type="checkbox"/> 3 <input type="checkbox"/> 4 <input type="checkbox"/> Other :		
Dust Protection	<input type="checkbox"/> Standard <input type="checkbox"/> U <input type="checkbox"/> UZ <input type="checkbox"/> UD <input type="checkbox"/> XN <input type="checkbox"/> UN <input type="checkbox"/> ZN <input type="checkbox"/> WW <input type="checkbox"/> WU <input type="checkbox"/> WZ <input type="checkbox"/> Other		
Rail Length / Butt joint	<input type="checkbox"/> Length mm Butt-joint : <input type="checkbox"/> NO <input type="checkbox"/> YES		
Pitch	G1: G2 :		
Accessory Code	<input type="checkbox"/> N (Normal) <input type="checkbox"/> H (High) <input type="checkbox"/> P (Precision) <input type="checkbox"/> SP (Super Precision) <input type="checkbox"/> UP (Ultra Precision)		
Preload	<input type="checkbox"/> ZF (Slight Clearance) <input type="checkbox"/> Z0 (No Preload) <input type="checkbox"/> Z1 (Light Preload) <input type="checkbox"/> Z2 (Medium Preload) <input type="checkbox"/> Z3(Heavy Preload)		
Rail Per Axis	<input type="checkbox"/> 1 <input type="checkbox"/> 2 <input type="checkbox"/> 3 <input type="checkbox"/> Other :		
Rail Mounting	<input type="checkbox"/> FromTop <input type="checkbox"/> K From Bottom <input type="checkbox"/> X Railwith Special Maching		
Special Cladding	<input type="checkbox"/> B (Black Oxidation) <input type="checkbox"/> O (Hard Chrome Plating) <input type="checkbox"/> P (Phosphating) <input type="checkbox"/> N (Nickel Plating) <input type="checkbox"/> D (Raydent)		
Lubrication Type	<input type="checkbox"/> Grease <input type="checkbox"/> Oil		
Lubrication Fitting	<input type="checkbox"/> Grease nipple (Code :) <input type="checkbox"/> Oil piping joint (Code :)		
Special Option	<input type="checkbox"/> Steel end seal <input type="checkbox"/> Steel end cap <input type="checkbox"/> Cover Strip <input type="checkbox"/> Other :		
TBIMOTION Model No.			
Reference surface & Injection Direction			

Memo

A large area of horizontal dashed lines for writing a memo.

Memo

A large area of horizontal dashed lines for writing a memo.

Memo

A large area of horizontal dashed lines for writing a memo.

TBI INSIDE



TBI MOTION TECHNOLOGY CO., LTD.

No.123, Sanduo Rd., Shulin Dist., New Taipei City 23876, Taiwan

TEL: +886-2-2689-2689 FAX: +886-2-2688-5933

E-mail: tbimotion@tbimotion.com.tw



Facebook



E-catalog